

## INTER OFFICE MEMO

**To:** Board of Directors

**Date:** 3/6/2024

**From:** J. Scott Mitchell, Chief Operating Officer

**Reviewed by:** *W.C.*

---

**SUBJECT: Approval of Revised Public Transportation Agency Safety Plan (PTASP)**

---

### **Background:**

On July 19, 2018, the Federal Transit Administration (FTA) published the Public Transportation Agency Safety Plan (PTASP) Final Rule, which requires certain operators of public transportation systems that receive federal funds under FTA's Urbanized Area Formula Grants to develop safety plans that include the processes and procedures to implement Safety Management Systems (SMS). County Connection's PTASP was approved and adopted by the Board of Directors at the November 2020 meeting. Per the Federal regulation 49 CFR Part 673, the PTASP must be updated and certified by the transit agency annually.

The purpose of the PTASP is to make working on and managing the bus transit system inseparable from delivering safe and "accident-free" service. This covers all the operations on property, onboard our buses, at our bus stops, and everywhere the County Connection operates. To fulfill this purpose, the plan establishes safety programs and practices that prevent accidents, injuries and illnesses; provides guidance on how to prepare for an accident or emergency and provides guidance on how to respond to hazards and incidents.

### **Safety Committee:**

On February 17, 2022, FTA issued a Dear Colleague Letter regarding changes to PTASP requirements as a result of the Bipartisan Infrastructure Law (BIL), also known as the Infrastructure Investment and Jobs Act (IIJA). One of the new requirements is for transit agencies that receive Section 5307 funding to establish a Safety Committee compliant with 49 U.S.C. § 5329(d)(5) by July 31, 2022. The Safety Committee is then required to approve an update to the agency's PTASP to incorporate the new requirements by December 31, 2022.

The Safety Committee is responsible for identifying and recommending risk-based mitigations or strategies as well as deficiencies. The Safety Committee consists of an equal number of frontline employee and management representatives. County Connection staff established and convened its first Safety Committee meeting on March 29, 2022. The Safety Committee continues to meet quarterly and oversees any revisions to the Plan.

Transportation and Training have implemented an Accident Reduction Program into the PTASP this year.

### **Financial Implications:**

None at this time.

**Recommendation:**

The O&S Committee recommend that the Board of Directors at its March 21, 2024, meeting, adopt Resolution No. 2024-015 authorizing the General Manager to recognize that County Connection has revised the Public Transportation Agency Safety Plan (PTASP).

**Action Requested:**

The O&S Committee recommend that the Board of Directors at its March 21, 2024, meeting, adopt Resolution No. 2024-015 authorizing the General Manager to approve the revised Public Transportation Agency Safety Plan (PTASP).

**Attachments:**

Attachment 1: Public Transportation Agency Safety Plan (PTASP)

Resolution No. 2024-015

# Central Contra Costa Transit Authority

## Public Transportation Agency Safety Plan (PTASP)

### Distribution

Chairman of the Board, Don Tatzin

General Manager, William Churchill

Chief Operating Officer, J. Scott Mitchell (Accountable Executive)

Assistant General Manager Administration, Ruby Horta

Director of Human Resources, Dawud Brewer

Chief Financial Officer, Amber Johnson

Manager of Grants and Purchasing, Kevin Finn (Chief Safety Officer)

Revised: April 11, 2022, November 15, 2022, February 2024

## Table of Contents

	Page
1 - Policy Statement and Authority.....	3
2 - Description of Purpose .....	4
3 - Goals .....	5
4 - Identifiable and Attainable Objectives.....	5
5 - System Description/Organizational Structure .....	6
6 - Hazard Identification/Resolution Process .....	9
Hazard Severity Categories .....	11
Hazard Probability Levels .....	12
Hazard Risk Assessment Index .....	13
Hazard Rating Table .....	13
County Connection Hazard Identification Report Form .....	14
7 - Accident/Incident Reporting & Investigation .....	15
8 - Facilities Inspections.....	15
9 - Maintenance Audits/Inspections .....	16
10 - Rules/Procedures Review .....	19
11 - Training and Certification Review/Audit.....	20
12 - Emergency Response Planning, Coordination, Training .....	26
13 - System Modification Design Review and Approval Process.....	27
14 - Safety Data Acquisition/Analysis .....	28
15 - Inter-Departmental/Inter-Agency Coordination .....	29
16 - Configuration Management .....	32
17 - Employee Safety Program.....	32
18 - Hazardous Materials Programs .....	33
19 - Drug and Alcohol Abuse Programs.....	33
20 - Contractor Safety Coordination .....	34
21 - Construction Safety Requirements .....	35
22 - Procurement .....	38
23 - Alternative Fuels & Safety .....	38
24 - Operating Environment and Passenger Facility Management.....	39
25 - Security.....	39
26 - Internal Safety Audit, Control and Update Procedures .....	40
27 - Injury & Illness Prevention Program (IIPP) Responsibilities.....	44
28 - Compliance.....	45
29 - Communication.....	46
30 - Safety Suggestions and Hazard Reporting.....	47
31 - Hazard Identification and Evaluation .....	47
32 - Injury/Illness Investigation.....	47
33 - Correction of Hazards.....	48
34 - Safety Performance Monitoring and Measurement.....	48
35 - Training.....	53
36 - Safety Performance Targets.....	55
37 - Safety Performance Target Coordination .....	56

## Appendices

Cal-OSHA Serious Injury/Illness Reporting Requirements .....	58
Employee Report Form.....	59
Employee Safety Training and Meeting Report .....	60
New Employee Safety Orientation Checklist.....	61
Safety Inspection Form/Action Plan.....	62
Supervisor's Investigation Report .....	64
Glossary.....	66
Revision Log .....	67
Occurrence Report Form	
Organizational Chart of County Connection	

# 1 POLICY STATEMENT AND AUTHORITY

## 1.1 Policy Statement

The Central Contra Costa Transit Authority (County Connection) Public Transportation Agency Safety Plan (PTASP) is an operational document intended to provide guidance to all management and staff through a well-defined process to achieve and maintain safety for all transit riders, employees, and visitors to our facility and revenue vehicles. Management will review this document on an ongoing basis to ensure safe environments and provide updates as appropriate.

The mission statement for safety is:

- Safety within County Connection is our highest priority. Through the combined efforts of the Operations, Maintenance, and Administrative teams, we will provide the safest possible transportation system and ensure safe conditions.
- During the operation of our vehicles, our bus operators will always conduct themselves in a professional manner with emphasis on safety towards passengers, motorists, pedestrians, and property alike.
- To assure that traffic accidents are kept to an absolute minimum, no unsafe vehicles will be committed to service nor will physical hazards and/or unsafe practices be allowed to remain uncorrected. Safety will always take precedence.
- Through employee safety awareness, we will strive to achieve and maintain our goal of being the safest transit agency in operation.

The PTASP was prepared by the Safety and Transportation Departments, and frontline employee representatives, which have direct responsibility for overseeing all safety-related issues within County Connection. Development of this plan was in accordance with the American Public Transportation Association's "Manual for the Development of Bus Transit Public Transportation Agency Safety Plans."

### Agency

County Connection was formed in 1980 as a Joint Powers Authority. County Connection assumed control of public bus service in and around Contra Costa County in the nine counties that make up the San Francisco Bay Area.

County Connection is governed by an eleven-member Board of Directors (Board) representing the cities of Clayton, Concord, Lafayette, Martinez, Orinda, Pleasant Hill, San Ramon, Walnut Creek, the towns of Danville and Moraga, and the unincorporated areas of Central Contra Costa County.

County Connection's facility is located at 2477 Arnold Industrial Way, Concord, California 94520. The County Connection service area is 200 square miles. Service area population is 482,400. Annual ridership is 3.5 million (fixed route and paratransit). County Connection's fixed route service operates 25 weekday routes, 8 express routes and 7 weekend routes.

The Board hires the General Manager to be responsible to the Board for the proper administration of all affairs of County Connection and to carry out the policies established by the Board.

## **2 DESCRIPTION OF PURPOSE**

The purpose of the PTASP is to make working on and managing the bus transit system inseparable from delivering safe and "accident-free" service. This covers all the operations on property, onboard our buses, at our bus stops, and everywhere the County Connection operates. To fulfill this purpose, the plan establishes safety programs and practices that prevent accidents, injuries and illnesses; provides guidance on how to prepare for an accident or emergency and provides guidance on how to respond to hazards and incidents. To achieve this purpose, the plan:

- Documents the County Connection commitment to safety on a system-wide basis.
- Provides a framework for implementation of safety policies and the achievement of safety goals and objectives for all personnel, passengers, contract employees, and service providers/vendors who come onto the property.
- Demonstrates compliance with Federal and State laws and local codes, ordinances and regulations.
- Sets training and performance standards to meet or exceed accepted industry safety standards on an ongoing basis.
- Establishes and manages safety activities intended to serve as countermeasures in minimizing risk and loss of resources, and to maximize the safety of the public.
- Integrates the safety function throughout the organizational structures.
- Defines organizational safety responsibilities.
- Provides for the documentation and verification of safety activities.
- Establishes evaluation activities to assure continued development and advancement of safety activities.

The link between delivering bus transit service and providing a safe work and customer environment comes from understanding and implementing a broad definition of safety throughout the organization. System safety is defined as system-wide coordination of all departments to apply operating and technical management techniques and principles to conserve life and property, prevent and reduce accidents/incidents and to maintain a safe and healthful work environment. The plan defines safety to include efforts to:

- Conserve life and property.
- Provide for the occupational safety and health for employees.
- Provide for the operational safety of passengers, employees, contractors and community members.
- Provide for community safety through education and awareness.
- Maintain safe operation interactions with other transit systems.
- Prevent accidents and injuries and reduce the frequency of safety-related incidents.
- Preserve the working condition of the property and equipment utilized in service.
- Ensure that the safety concerns of the elderly and those with disabilities are addressed.

At a minimum, safety includes driving vehicles safely, having safe working areas for all employees, having bus stops that are inviting and safe for our riders, taking safety into consideration whenever purchasing new vehicles or equipment, and in designing and building any part of the infrastructure. County Connection takes great pride in the number of accident-free miles it drives each year and is determined to make the percentage an ever-increasing percentage of our total miles driven.

### **3 GOALS**

The overall goal of the PTASP is to identify, minimize and control safety hazards and their risks by establishing requirements, lines of authority, levels of responsibility and accountability, and methods of documentation for the organization.

- Management has the responsibility to provide the necessary safety and training of employees.
- Each employee has the responsibility to receive, understand and use the training as provided.
- In the performance of their assigned work, each employee is expected to do their work safely and follow correct operating procedures, as a condition of employment.
- Ensure that no single point of failure of equipment results in an unsafe condition.
- Promote a uniform safety philosophy and culture throughout County Connection.
- Identify and eliminate or control, when possible, hazards through the use of an established safety hazard process.
- Provide management and staff with a consolidated reference, including all current safety policies and procedures in place, for educational and accountability purposes.
- Transportation and Maintenance Departments will establish annual key performance indicators and provide a monthly status report to management and department employees.

The purpose of these goals is to minimize the exposure to hazards and unsafe conditions to personnel, property, and our customers. These goals are reflected in the planning, design, construction, operation and maintenance of the transit system.

### **4 IDENTIFIABLE AND ATTAINABLE OBJECTIVES**

Objectives are the working elements of the PTASP, the means by which the previously stated goals are to be achieved. Unlike goals, objectives must be able to provide a meaningful framework for the day-to-day activities that provide a safe transit operation.

The primary objective of the PTASP is to develop, implement, and maintain a safety effort comprised of strategies and tactics to continually review and improve the safety performance.

- Transportations Training, Safety and First-Line Supervisors, as appropriate, shall provide safety training to all new employees and to employees with assignment changes, as appropriate.
- Transportations Training shall provide Defensive Driving training to all Transportation and Maintenance employees and to all employees who drive County Connection vehicles.
- Facility Maintenance shall provide Emergency Spill Response training to Maintenance employees.
- Transportations Training shall provide optional AED/CPR/First Aid training open to all County Connection employees.
- Transportation Department shall investigate all accidents/near-misses and or incidents for purposes of identifying and documenting causes with the aim of implementing corrective action(s) to prevent recurrence.
- Facility Maintenance shall conduct quarterly facility inspections at County Connection.
- Human Resources shall make available County Connection's Injury & Illness Prevention Program (IIPP) to all employees as part of the New Hire Orientation.
- Transportation Department shall conduct a Safe Driver Award program for Operators of revenue vehicles.
- Company-wide there is an Employee of the Quarter Award based on perfect attendance, no accidents, and no written warnings. Four employees are chosen.

Specific programs, such as the Injury & Illness Prevention Program, Hazardous Materials Business



Plan, Spill Prevention, Control and Countermeasures Plan, Storm Water Pollution Prevention Plan, Hazardous Waste Source Reduction Plan, Sludge Discharge Prevention and Contingency Plan, Right to Know Plan, Emergency Operations Center Online Guide, and the Substance Abuse Alcohol Misuse Prevention Program, have been developed and implemented for:

- Identifying and eliminating or controlling of hazards to the public, employees, and property.
- Maintaining and operating the property and equipment in a safe and effective manner.
- Providing a working environment that meets or exceeds all government and industry occupational health and safety standards and practices.
- Responding to emergency response agencies to all company-related emergencies.

The Safety Policy is established in the County Connection *Employee Safety Manual*. The safety program incorporates public, employee, and property safety to include life safety, fire loss, and loss prevention in the following programs:

- Monthly Shop Safety Meetings in Maintenance.
- Quarterly Operations and Maintenance Safety Committee Meetings.
- Training programs for all new hires.
- Annual hazardous materials training for all appropriate personnel.
- Defensive Driver training for any personnel who drive or might drive a company vehicle.
- Personnel training/testing documentation.
- Disaster preparedness and emergency response training in accordance with County Connection's Emergency Plan and facility evacuation procedures.

## **5 SYSTEM DESCRIPTION/ORGANIZATIONAL STRUCTURE**

This section is to define both the transit system's physical characteristics, including service and performance parameters, and the organizational structure of the system.

### **5.1 System Description**

#### **5.1.1 History**

On July 1, 1980, County Connection began service with its first route serving Walnut Creek. The change over from AC Transit to County Connection was somewhat gradual, with County Connection assuming the remainder of the service by 1982.

#### **5.1.2 Scope of Service**

The overall purpose of County Connection is to plan, develop, finance and operate a modern, coordinated system of transportation that meets local mobility demands and promotes growth and economic development for the region. County Connection provides bus transit services throughout Central Contra Costa County. County Connection also operates a paratransit service, and funds shuttles connecting to BART stations and employment centers. Currently, County Connection operates 125 buses and 63 paratransit vehicles.

County Connection works with Livermore Amador Valley Transit Authority (LAVTA) to provide coordinated paratransit services that serve both County Connection and LAVTA customers.

#### **5.1.3 Facility, Bus Shelters and Stops**

The facilities system includes all building structures, plumbing, electrical, heating and air conditioning, pavement management, lighting, parking, bus maintenance, and cleaning and fueling facilities. Four buildings are located on the facility property:

	<u>Building Square Footage</u>
#1 – Maintenance	41,853
#2 – Administration	17,526
#3 – Bus Wash/Fuel Island	7,437
#4 – Paratransit	10,064

County Connection maintains 1,288 bus stops. Anodized aluminum and glass passenger shelters are provided at 164 bus stops within Contra Costa County. Shelters are located at transfer points, shopping centers, hospitals, BART stations and park and ride lots. Many of these shelters are provided by Outfront Media, which places ads in them, as well as maintains them.

Within Contra Costa County, significant trip generators include the eight BART stations served, as well as Diablo Valley College and Bishop Ranch. Other destinations include Sun Valley Mall, San Ramon Transit Center, St. Mary's College, Mitchell Drive Park & Ride, Martinez Amtrak Station, ACE Pleasanton, and Broadway Plaza.

County Connection also has several partnerships with local jurisdictions, major employers, and business districts to provide shuttle bus service, which primarily operate during the morning and evening weekday peak periods and is offered for free to the general public with fares being subsidized by the employers they serve and various granting partners.

Ridership and operating statistics are monitored monthly. County Connection implements new run books in January, June, August, and November. At these times, new service and schedule modifications can be introduced. Service modifications may include route expansions, consolidations, alterations or deletions. Minor adjustments and fine-tuning of running times are also made at these times.

County Connection fixed-route buses are wheelchair accessible. Reduced fares, as well as designated front seating, are provided for customers with disabilities and the elderly. Paratransit service is available for those unable to use fixed-route bus service as established by the Americans with Disabilities Act (ADA).

County Connection works with local jurisdictions to ensure wheelchair access at bus stops. Benches, shelters, curb cuts and other bus stop improvements are prioritized for areas where large numbers of elderly and persons with disabilities wait for the bus. County Connection is committed to continuing special training for bus operators and customer service representatives.

#### **5.1.4 Maintenance**

The Maintenance Department is managed by the Chief Operating Officer who is responsible for the maintenance oversight of the entire fleet of 125 revenue vehicles and 20 non-revenue service support vehicles, such as sedans, pickups, and forklifts. To assist the Chief Operating Officer, there is a Director of Maintenance and a Manager of Maintenance. Our Buyer is responsible for parts and inventory control. Maintenance has an authorized workforce of 27 employees. Standard shifts are eight hours. Mechanic support is provided as follows:

- 1st Shift consists of mechanics who report to work at 4:00 a.m. and work to 12:30 p.m.
- 2nd Shift consists of mechanics who report to work at 7:00 a.m. and work to 3:30 p.m.
- 3rd Shift consists of mechanics who report to work at 12:30 p.m. and work to 9:00 p.m.
- 4th Shift consists of mechanics who report to work at 3:30 p.m. and work to 12:00 a.m.
- Saturday consists of one mechanic who reports to work at 1:30 p.m. and works to 10:00 p.m.
- On Sunday a Mechanic VI is on call.

Mechanics are responsible for preventative maintenance inspections, general repairs, engine and transmission repairs, brake repairs and other repairs. Maintenance crews also are responsible for repairing items noted on the Daily Bus Operator Vehicle Safety Report, handling road calls, and repair of minor defects. Maintenance strives for the best-suited candidates for Mechanic I to Mechanic VI levels. As for the individuals, they develop a win-win situation with increases in mechanics' knowledge and current technological depth. There is a total of 14 mechanics.

The Service Worker shifts are from 4:00 a.m. to 12:00 a.m. Monday through Friday. One Service Worker works on Saturdays 1:30 p.m. to 10:00 p.m. Service Workers are primarily involved in the servicing (fluid levels and refueling) and cleaning of the fleet of revenue vehicles. The total number of Service Workers is 11.

There are two Storekeepers. Their shifts cover from 7:00 a.m. to 11:00 p.m.

#### **5.1.5 System Modifications**

Modifications are made to the systems as conditions warrant during ongoing re-evaluations of Operations and Maintenance standard operating procedures. This process is detailed in the Standard Operating Procedure (SOP) #M-1. System modifications applicable to Maintenance are monitored through this same process, complimented by in-house Maintenance Campaign Bulletins.

#### **5.1.6 Organizational Structure**

County Connection operates through departments under the direction of the General Manager.

The General Manager is responsible for directing and overseeing all activities and for providing support to the Board of Directors, the Operations Department, and the Maintenance Department.

The Assistant General Manager Administration provides management assistance to departments and is responsible for Human Resources. This position is also responsible for the shuttles programs, paratransit services, ADA services pursuant to the requirements of the Americans with Disabilities Act (ADA), quality assurance, intelligent transportation systems, and service scheduling and planning.

The Finance Department is responsible for financial accounting and reporting, capital budgeting, operational budgeting, payroll and vendor disbursements, investments and cash management, debt management, revenue control, purchasing, contract administration, risk management, and information technology.

The Planning, Grants and Marketing Department is responsible for fare media, customer service, marketing, sales, advertising, distribution services, public information, media relations, legislative activities and community outreach.

County Connection is governed by an eleven-member Board of Directors. The Board meets once a month to determine overall policy for County Connection. Meetings are open to the public. Agendas are available online approximately one week before the meetings. Members of the public are invited to attend the Board meetings and address the Board on transportation issues directly during the "Public Comment" portion of the meeting.

Directors serve on standing and ad hoc committees of the Board to review Company matters and make recommendations to the Board. These committees usually meet once a month and include:

- Administration & Finance
- Marketing, Planning & Legislative
- Operating & Scheduling

Input to the Board comes from multiple sources including a Citizens Advisory Committee (CAC). The CAC members represent Contra Costa County's bus riders, multimodal transit riders, and community at large. The CAC members, appointed by the Board, meet bi-monthly and advise the Board on aspects of County Connection policy.

#### **5.1.6.1 Lines of Communication from Safety Within County Connection**

Communication from Safety to the General Manager utilizes two channels. The primary channel is through the Chief Operating Officer/COO. The secondary channel is directly to the General Manager for critical, time-sensitive distribution. The Chief Safety Officer (Kevin Finn) can report relations directly to the General Manager.

### **6 HAZARD IDENTIFICATION/RESOLUTION PROCESS**

The purpose of this section is to describe County Connection's formal manner of hazard identification and resolution, how to ensure that all hazards are adequately addressed, and the resolution process itself is properly documented.

#### **6.1 Hazard Identification**

The objective of hazard identification activities is to define those conditions and faults, which have the potential for causing an accident. Employees are asked to use the Hazard Identification Report Form found at the end of this section.

The actual hazard identification process includes the use of various sources of information including the input of Operations and Maintenance personnel such as:

- Observation of work practices, work areas and equipment for obvious or potential unsafe conditions
- Periodic facility inspections
- Worker safety suggestions or complaints
- Reports of hazards by employees
- Accident or near-miss investigations
- Post-accident analysis

County Connection provides all employees with both verbal and written means to communicate with management and the Safety Department concerning potential hazards or unsafe conditions. State law protects reporting unsafe conditions or practices. The District will investigate any report or question as required by California Labor Code section 6401.7 or California Code of Regulations Title 8 Section 3203 and advise the employee who reported such information and the workers affected by the results of all ensuing investigations.

#### **6.1.2 Facility Work Orders**

All County Connection employees may submit an email to Facilities requesting a wide range of services from moving heavy objects such as furniture or boxed documents, to reporting unsafe physical situations to be resolved, such as buckled carpeting or exposed wiring. System users receive reply emails alerting them 1) that their work order has been logged, 2) when it has been

assigned and to whom, and 3) when the work has been completed.

### **6.1.3 Injury & Illness Prevention Program (IIPP)**

County Connection's Injury & Illness Prevention Program or IIPP can be found in the *Employee Safety Manual*, which is maintained by the Human Resources Department. A copy of the IIPP is available to employees and/or any member of the public on the County Connection website. It may also be provided upon request in writing by the employee to the IIPP Administrator. It includes instructions on reporting hazards and a copy of the Hazard Identification Report Form. All employees are encouraged to bring all known hazards to the attention of both management and the Chief Safety Officer. In accordance with State law, employees may report hazards anonymously as well. (See attached Employee Report Form.)

### **6.1.4 Service Change Request (SCR)**

A "Service Change Request" or SCR is completed by bus operators to document operational and safety issues of concern with regard to runs, routes, schedules, stops, tree trimming, on-time performance, and other such related matters. They are categorized as "Suggestion, Normal Business, or Urgent Business" by the bus operator who then enters the report online. The report is forwarded to the appropriate department for review and response.

### **6.1.5 Operator Incident Report**

An "Operator Incident Report" is completed by bus operators who wish to report passenger interaction issues, or any incident that needs to be communicated to the Manager. Unusual incidents and events not covered under the Service Change Request form, or unresolved maintenance issues. The bus operator who completes the form then gives the document to the Transportation Dispatcher, who then routes it to the Transportation Manager for review, evaluation and processing.

### **6.1.6 Incident Report**

An Incident Report is completed by Dispatch or Maintenance to report concerns about work conditions or events regarding Company personnel, physical property, or passenger issues affecting, or being affected by, our buses. Incident Reports are routed to the Chief Operating Officer or Director of Transportation for review and evaluation.

### **6.1.7 Safety Committee Meetings**

Safety Committee Meetings are joint management-labor quarterly meetings for the purpose of discussion and resolution of safety issues affecting employees, or the riding public.

### **6.1.8 Shop Safety Meetings**

Shop Safety Meetings are held once a month across all shifts within the Maintenance Department. Employees may bring up new safety items during the meetings or request the items to be added to future meeting agendas. Copies of the "Shop Safety Meeting" are distributed to the Chief Operating Officer, and include the officiating managers name, the date and shift holding the meeting, discussion topics, and also serves as the meeting's sign-in sheet in accordance with "Maintenance Safety."

### **6.1.9 Operator's Inspection Report**

The "Operator's Inspection Report" is handed to each Bus Operator before they drive a bus off property. These reports are used daily for the recording of all pre-trip and post-trip inspection findings by the employee assigned to operate each individual bus for all or part of their work shift verifying that the bus is safe and roadworthy. All items found to be defective either prior or during operation of the bus must be reported on the "Operator(s) Defects Report." (See Section 9.1 for Operator(s) Defects Report procedures.) The Operator's Inspection Report is turned into Dispatch

at the end of their shift. These daily vehicle inspection procedures are documented in "Vehicle Inspection Procedure."

### 6.1.10 Radio Control Dispatch

The Radio Control is located in the Administration Building inside of Operations. Dispatchers perform the dispatching duties to direct-operated bus service. The Radio Control operates Monday through Sunday, 3:00 a.m. till 12:00 a.m., and weekends 5:30 a.m. till 10:30 p.m.

Radio Control and Dispatchers utilize radio and phone communications systems, which are recorded lines; thus, all hazard reports are captured and can either be addressed by the Radio Controllers/Dispatchers or forwarded to the Manager for review and evaluation as appropriate.

## 6.2 Hazard Categorization

For those hazards that are not addressed by the various procedures, an ad hoc committee is to be convened by the department director most affected by the hazard identified and included in this section is a method for categorization of all identified hazards. Hazards are normally categorized in terms of severity and probability of occurrence. For the probability of occurrence, the following categories are employed; Frequent, Probable, Occasional, Remote, Improbable and Design Resolved. For severity of event consequences, the analysis uses Catastrophic, Critical, Marginal, Negligible. Each aspect will be represented in a matrix to determine the required disposition.

### 6.2.1 Hazard Severity

Hazard severity is defined as a subjective measure of the worst credible mishap resulting from personnel error, environmental conditions, design inadequacies or procedural efficiencies for system, subsystem, or component failure or malfunction, and is categorized as follows:

#### Hazard Severity Categories

<u>Description</u>	<u>Category</u>	<u>Definition</u>
CATASTROPHIC	I	Death, system loss, severe environmental damage, or complete and extended disruption of service.
CRITICAL	II	Severe injury, severe occupational illness, major system environmental damage, or major disruption of service.
MARGINAL	III	Minor injury, minor occupational illness, or less than minor system, environmental damage, or less than minor disruption of service.
NEGLIBIBLE	IV	Less than minor injury, occupational illness, or less than minor system, environmental damage, or less than minor disruption of service.

Disruption of Service refers to a disruption resulting from reported damage to equipment, facilities, and/or other property as a result of a collision, or any event that is not addressed through routine Operations' practices or procedures.

### 6.2.2 Hazard Probability

Hazard probability is defined as the probability that a specific hazard will occur during the planned life expectancy of the system element, subsystem or component. It can be described subjectively in potential occurrences per unit of time, events, population, items or activity. A qualitative hazard probability may be derived from research, analysis, and evaluation of safety data from the operating experience historical safety data from similar systems. An example of hazard probability ranking is shown in the following:

#### Hazard Probability Levels

<u>Description</u>	<u>Level</u>	<u>Specific Item</u>	<u>Fleet/Inventory</u>
FREQUENT	A	Likely to occur frequently.	Continuously experienced.
PROBABLE	B	Will occur several times in the life of an item.	Will occur frequently.
OCCASIONAL	C	Likely to occur sometime in the life of an item.	Will occur several times.
REMOTE	D	Unlikely, but possible to occur in the life of an item.	Unlikely but can reasonably be expected to occur.
IMPROBABLE	E	So unlikely it can be assumed occurrence may not be experienced.	Unlikely to occur, but possible.

### 6.2.3 Hazard Resolution

Once a hazard is identified, an analysis is performed to define its potential severity and probability of occurrence as defined in the previous two sections. Hazard resolution is defined as the analysis and subsequent actions taken to reduce to the lowest level practical the risk associated with an identified hazard. Procedures have been established for resolution of potential hazards. Once the supervisor receives a report of a potential hazard from anyone at the facility, the supervisor shall report the hazard to their respective Director, who shall notify the Chief Safety Officer when circumstances are outside pre-established response procedures. The Chief Safety Officer will notify the Chief Operating Office and the General Manager as appropriate.

Each hazard will be categorized. For the probability of occurrence, the following categories are employed; Frequent, Probable, Occasional, Remote and Improbable. For severity of event consequences, the analysis uses; Catastrophic, Critical, Marginal and Negligible. Each aspect will be represented in a matrix to determine the required disposition.

Hazard Risk Assessment Index and Hazard Rating Table charts show which actions need to be taken as follows:

<u>Frequency of Occurrence</u>	<b>Hazard Risk Assessment Index</b>			
	<u>Catastrophic (I)</u>	<u>Critical (II)</u>	<u>Marginal (III)</u>	<u>Negligible (IV)</u>
FREQUENT	IA	IIA	IIIA	IVA
PROBABLE	IB	IIB	IIIB	IVB
OCCASIONAL	IC	IIC	IIIC	IVC
REMOTE	ID	IID	IIID	IVD
IMPROBABLE	IE	IIE	IIIE	IVE

#### **Hazard Rating Table**

<u>Risk Category</u>	<u>Hazard Risk Index</u>	<u>Acceptance Criteria</u>
1	IA, IB, IC, IIA, IIB, IIIA	Unacceptable
2	ID, IIC, IID, IIIB, IIIC	Undesirable
3	IE, IIE, IID, IIIE, IVA, IVB	Acceptable with review
4	IVC, IVD, IVE	Acceptable without review

#### **6.2.4 Hazard Closure**

The close out process is the most critical of the safety management process. The responsible manager(s), depending on the subject matter, are responsible for arranging follow-up action. The responsible manager shall also ensure that appropriate internal budgeting, cost, and capital project prioritizing are initiated, as required by the hazard resolution. If system design standard revisions are warranted, or changes and additions to long-term capital maintenance and improvement programs are needed, these shall be reviewed through the Configuration Management process.



**County Connection Hazard Identification Report Form**

Date of report:

\_\_\_\_\_

Date hazard discovered:

\_\_\_\_\_

Submitted by (please sign and print):

\_\_\_\_\_

Signature

Phone: (\_\_\_\_) \_\_\_\_\_

Cell: (\_\_\_\_) \_\_\_\_\_

Print

Are you a County Connection employee?    Yes    No    (circle one)

Describe hazard:

What is exact location of hazard?

What are consequences of hazard?

Has hazard harmed anyone or damaged anything already?

Your suggestions for minimizing or abating the hazard:

Route this form to 1) Your direct supervisor, 2) Chief Safety Officer, 3) Keep copy for yourself.

## **7 ACCIDENT/INCIDENT REPORTING & INVESTIGATION**

All accidents and any related injuries must be reported immediately. An accident report is an official document and must be completed accurately with sufficient detail. In the event of a vehicular accident involving revenue service, the Operator must contact Radio Control/Dispatch immediately who will then send out a Dispatch supervisor to the scene. Injured employees may be sent to a physician, industrial clinic or hospital depending on the time of day and or the type of injury. As soon after the accident as possible, the supervisor must document the facts of the accident and recommend suitable corrective action to prevent recurrence. In the cases of preventable accidents, or non-preventable accidents based on equipment failure, either the supervisor or Accountable Executive (Scott Mitchell) can request the accident report be forwarded for Hazard Identification and Resolution.

The following list outlines the adopted Standard Operating Procedures related to County Connection's response in the event of a vehicular collision:

- Dispatch: Vehicular Collision/Accident Investigation
- Dispatch and Training: Vehicle Accident Retraining
- Operators: Bus Operator Accident Reporting Procedures
- Maintenance: Revenue Vehicle Brake Inspection After Accident

## **8 FACILITIES INSPECTIONS**

Our facilities inspections are detailed in our FTA Facilities Equipment and Maintenance Plan. In summary, the goal of the maintenance program is to enhance quality, sustain safety, and maintain good state of repair of the district's facility in addition to minimize service interruptions and reduce operating and maintenance costs.

Preventative maintenance cycles are developed for a number of pieces of equipment as well as for all park and rides, bus stops, and shelters. Each piece of equipment is assigned an equipment number and facility ID location. In most cases, the original equipment manufacturer (OEM) manufacturer's recommendations are followed; in other cases, the established intervals are either longer or shorter than the OEM recommendations. When deviations from the OEM recommendations occur, research and data collection are used to develop the appropriate maintenance cycle.

The Facility Superintendent schedules and monitors facility inspections. Work orders are generated daily using an electronic maintenance management system for specific equipment or areas of the facility.

Inspection intervals/cycles range from daily to annual, with several being as long as triennial. Most equipment is scheduled for monthly, quarterly, semiannual, and annual inspections. Facilities inspections include all operating, maintenance and administrative structures.

The following is a list of facilities/specialized equipment with specific safety-related characteristics and their individual inspection schedule:

### **8.1 Employee Safety**

- Air Compressors: tested monthly, State certification every five years.
- Automated External Defibrillators: inspected monthly.
- Elevators in Administration, Maintenance and Paratransit Buildings: inspected monthly.
- Emergency Generators: tested weekly.
- First Aid Kits: stocked monthly.
- Forklifts: inspected monthly, serviced annually.

- Ingress/Egress: checked daily.
- Overhead Piping: checked daily.
- Overhead Cranes: inspected quarterly, full system inspection annually.
- Underground Hoist: inspected quarterly.
- Uninterrupted Power Supply (UPS) in Administration Building: tested annually.

## **8.2 Fire Protection Equipment**

- Fire Alarms: tested quarterly.
- Fire Extinguishers: serviced annually, tags checked monthly.
- Full Fire Extinguishing System: test every five years.
- Fire Hose Cabinets: tested annually.
- Panels: test semi-annually.
- Sprinkler System: flow test quarterly.

## **8.3 Environmental**

### **8.3.1 Storm Water Outfall**

- Rainy Season: visual check monthly, water samples four times.
- Underground Storage Tanks: continuous monitoring, weekly self-test, annual system test.
- Secondary Containment: continuous electronic monitoring test 3 years.
- Leak Detection Equipment: functional test annually.

### **8.3.2 Other**

- Bus Shelters: debris removed once per week and cleaned monthly.
- Bus Wash: inspected daily, cleaned out quarterly.
- Heating, Ventilation, Air Conditioning Systems (HVAC): serviced quarterly.

## **8.4 Emergency Preparedness**

- Rider Scrubber: inspected weekly, serviced monthly.
- Power Generators (Gen 1 and Gen 2): inspected monthly, serviced every 6 months.
- Yard Carts: inspected monthly, serviced annually.

## **9 MAINTENANCE AUDITS/INSPECTIONS**

The Maintenance Department is responsible for the maintenance of 125 fixed-route buses.

### **9.1 Preventative Maintenance (Operator(s) Defects Report)**

The first and most frequent type of preventative maintenance inspection performed is the daily Operator Defect Card (Operator(s) Defects Report). This inspection is performed before the bus departs the yard AM and PM. All daily Operator Defect Cards are picked up by Maintenance twice a day and reviewed. If a defect is noted on the daily Operator Defect Card, a maintenance work order detailing the defect is created and work order number is written on the Operator Defect Card. The maintenance work order is then assigned to a mechanic for appropriate corrective and testing action.

The Maintenance Department has an effective preventive maintenance program based on major and minor vehicle inspections, which are outlined and updated through the CIMS Maintenance Program and governing Standard Operating Procedures (SOP). These preventive maintenance inspections are performed at specific mileage intervals and are consistent with the original equipment manufacturer (OEM) recommended service intervals, APTA standards and/or with industry best practices. The mileage between inspection intervals is computer tracked, providing management with a report on the mileage since the previous inspection. The mileage information

is based on hubodometer readings, which are captured every night in the service lane by the Service Workers.

The Preventive Maintenance Inspection consists of:

- “A” Inspections – Support vehicles, 4,500 miles or every 6 months.
- “B” Inspections – Refers to preventive maintenance inspections performed on buses at 6,000 miles.
- “C” Inspections – are major preventive maintenance performed on buses at intervals in order and in continuous repeating cycle.

Major inspections such as “C” are developed specifically for each sub-fleet, e.g., Gillig low-floor, Gillig Hybrid, Gillig electric, etc. In addition, there is a comprehensive preventive maintenance and inspection program for all major components/accessories such as air conditioning unit, wheelchair lift/ramp, engine emission system, camera, radio, and automatic passenger counter.

All major component/accessories inspections are performed every B and C inspection. Preventive maintenances are performed at intervals that meet or exceed FTA’s 85% scheduled on-time performance.

All major preventive maintenance inspections are scheduled from the daily Preventive Maintenance Due report on CIMS. A maintenance work order is created and assigned to a mechanic with the appropriate preventive maintenance checklist. The vehicle undergoes a complete safety inspection and system’s check of exterior, interior, undercarriage, engine compartment, wheelchair ramp, air conditioning unit, and major components followed by a road test. Lubrication of the chassis, checking and changing of all prescribed fluids/filter also is performed. The mechanic performing the inspection records all defects found on the preventive maintenance CIMS work order program in accordance with the corresponding categories; exterior, interior, undercarriage, engine, air conditioning and wheelchair ramp.

Upon completion of the preventive maintenance inspection, a separate work order is generated for the repair of all preventive maintenance defects. The repair work order is generated by management and assigned to a mechanic for repair. All defects are repaired prior to returning the bus to revenue service. No repairs are deferred.

Maintenance has a quality assurance program for the preventive inspection process. The Chief Operating Officer requires the Director of Manager and the Manager of Maintenance to spot check and sign off on the quality of the preventive maintenance inspections. Maintenance measures and reports monthly, the number of preventive maintenance inspections, mileage intervals between inspections, and fleet service calls to confirm the inspection program is effective.

County Connection’s preventive maintenance program is designed, monitored, and executed to meet and exceed the fleet performance reliability of 6,000 miles between service calls.

## **9.2 General Repair (Unscheduled Repairs)**

Repairs on buses are initiated in several ways:

- First, a repair can be initiated in response to an Operator Defect Card. Daily Operator Defect Cards are forwarded to Maintenance for review daily. If a defect is noted on the Operator Defect Card, a maintenance work order detailing the defect is created. The maintenance work order is then assigned to a mechanic for repair.

- Second, a work order can be initiated by a Service Worker who cleans and services the buses. When a bus is driven through the service lane, if a vehicle defect is noted, it will be noted on the Fuel Island Report, then the Director or Manager will generate a maintenance work order detailing needed repairs and assign it to a mechanic.
- Third, a work order can be initiated in response to a service call. A work order is issued for all service calls. The corrective actions and/or repairs are documented accordingly. Maintenance tracks service calls by bus number, date, and type of service call. This information is then captured in the Road Call Report, which is generated each day if a road call occurs. This information is accumulated on a monthly basis and forwarded to the Chief Operating Officer.
- Fourth, a work order can be initiated by a supervisor quality control check or reported as found damage by a Mechanic or Service Worker at any time.
- Fifth, a work order can be initiated in response to a transit safe complaint.

Maintenance operations/activities span six days a week. From Monday through Saturday, County Connection has multiple shifts covering 20 hours. While on Saturday, there is one shift. Sunday is on-call.

The flow of work through the shop is coordinated by the Director of Maintenance and Manager of Maintenance. Day shift performs most of the defect and major repairs, and brake inspections. Swing shift performs most of the Operator Defect Card and brake inspections, and the majority of preventive maintenance inspections in progress. The goal is to meet morning pull-out and to provide additional support throughout the day.

Maintenance has a computerized work order system. The work order lists pertinent vehicle information, date, supervisor who created it, defect and shop. The repairs made, the amount of time spent performing them, parts used, and the employee who performed the work are documented on the computerized work order form. Completed work orders are signed off by the Director and Manager and then filed.

### **9.3 Fleet Owner Inspection and Maintenance Station License**

Pursuant to California Code of Regulations Title 13 Section, Article 3, Section 619 et seq., Maintenance facilities are licensed by the California Highway Patrol enabling County Connection, as fleet owners, to operate inspection and maintenance stations to certify their vehicles are in compliance with applicable provision of:

- California Code of Regulations Title 13 – Motor Vehicles
- The State of California Vehicle Code
- Display official stickers on their vehicles as evidence of certification

This license is non-transferable and any change in ownership or control of the licensed activity shall require a new license.

In addition, the California Highway Patrol conducts annual inspections, consisting of random inspections of vehicles, maintenance records, and other records. See Section 11 (Training and Certification Review/Audit.) The State of California inspector then issues a “Safety Compliance Report/Terminal Record Update.”

### **9.4 Maintenance Standard Operating Procedures**

The following is a list of Standard Operating Procedures adopted by County Connection related to vehicle maintenance:

- Maintenance, Minor “A” Inspection Procedures
- Maintenance, Brake Inspection After Accident
- Maintenance, Preventive Maintenance Transit Buses
- Maintenance, Inspection and Maintenance Station

In addition to the above procedures, the Director also writes and adopts “Maintenance Campaign Bulletins” and “Maintenance Technical Bulletins”, which are generated on a variety of vehicle maintenance-related issues as needed.

## **10 RULES/PROCEDURES REVIEW**

To ensure safe and efficient operations, all safety-sensitive County Connection employees are trained to perform their jobs according to formally developed and authorized rules and procedures pertaining to specific job functions. One of the most important functions of County Connection is to ensure that rules and procedures are appropriately developed, controlled, distributed, and periodically reviewed. Department Directors are tasked with ensuring these requirements are met.

Immediate changes to work plans, rules and procedures take the form of Operational Notices, Campaign Bulletins, Maintenance Technical Bulletins, and Notices to Operators. Longer term procedural changes are incorporated into the Standard Operating Procedures. These governing documents are dated, issued by indicated authority, serialized and archived, and reside in accessible areas for employee review. Master copies of these documents reside in the Director of Transportation and Maintenance offices.

### **10.1 Process Changes**

#### **10.1.1 Operational Notice**

Operational Notices issued by the Chief Operating Officer take precedent over all other instruments and communications. Similarly, Director-issued Notices supersede SOPs, Rules, prior Notices, Campaign Bulletins, and Maintenance Technical Bulletins. A safety notification would be issued as an Operational Notice. Through an annual review process, applicable information is incorporated into SOPs or Rules.

#### **10.1.2 Campaign Bulletin**

This document defines a specific operational project and associated work order for the Transportation or Maintenance departments. These bulletins are issued on authority of Director of Maintenance.

#### **10.1.3 Maintenance Technical Bulletin**

This document addresses a specific fleet or sub-fleet problem, the identified solution, and specific work instructions. These bulletins are issued on authority of Director of Maintenance.

#### **10.1.4 Notice of Operators**

This document is prepared by staff, generally a Transportation Supervisor, and is issued on authority of Managers. These usually address specific operational technical details, such as a re-routing and bus stop closures.

#### **10.1.5 Standard Operating Procedures**

Internal procedures and practices are put into writing and adopted in accordance with Standard Operation Procedure (SOP) #M-1. This document defines the process concerning how SOPs are regularly reviewed and updated, validated, or eliminated, and how new SOPs are created.

## **10.2 Rules**

The Transit Operators Training Manual is re-issued upon review and revision by the Training Department. The final product is submitted to the Chief Operating Officer for review and approval. Once approved, the revised Rulebook is posted to the network drive for "read only" access, and copies distributed to the workforce. To clearly define and communicate critical safety and security concerns, a section of the Rulebook called "Safety" lists all such rules. These are the most critical rules operating personnel must know and obey.

The controlling documents described above define the way we safely and efficiently conduct business. Unauthorized variation from these instructions constitutes a disciplinary infraction and subjects the offender to investigation and possible progressive disciplinary action. Professional management and correction of compliance issues ensures reliable adherence to controlling documentation requirements.

## **10.3 Employee Performance Management Evaluation Process**

The Performance Management Process utilizes differentiating competencies and related behaviors as a focal point in performance appraisals. These are behavioral goals in the sense we are asking supervisors to work with direct reports to identify 2-3 competencies and related behaviors to support agreed upon performance goals. While there is a specific competency titled "Technical/Professional Expertise", there is not one titled "Safety." As we continue to follow our Safety Management System (SMS) format, safety responsibilities are every employee's responsibility.

# **11 TRAINING AND CERTIFICATION REVIEW/AUDIT**

## **11.1 Training**

Proper qualifications of operating and maintenance personnel are an important part of a safe transit environment. The County Connection Operations Training Department maintains all training documentation and records. Full-time instructors are certified by the Transportation Safety Institute (TSI), a division of the Federal Transit Administration (FTA) and under the U.S. Department of Transportation (USDOT), and the Department of Motor Vehicles Employer Testing Program (ETP). An adjunct staff of qualified Bus Operators, known as Bus Operator Trainers, who are also certified US DOT TSI, assists in completing training assignments when demand exceeds departmental capacity. At least one instructor is certified by the American Red Cross to conduct First Aid/CPR/AED training.

## **11.2 Bus Operator Training**

### **11.2.1 New Bus Operators**

New Bus Operators receive up to six calendar weeks of training under US DOT certified instructors. All Instructors and Bus Operator Trainers are fully certified trainers, and all training hours are certifiable on a DMV Transit Driver Training Record form DL 260. (The DL 260 document is completed by the employer to ensure proper yearly hours are given to holder of a Verification of Transit Training (VTT) card.)

The hours trainees receive are both classroom and behind the wheel as outlined in the TSI training guidelines using TSI PowerPoint slides, TSI Instructor manuals and TSI participant manual augmented with specific material from County Connection. County Connection's materials include SOPs, County Connection's equipment (buses) and other information exclusive of County Connection. Additionally, the U.S. DOT, Federal Motor Carrier Safety Administration (FMCSA) Entry-Level Driver Training (ELDT) Minimum Federal Curricula Requirements mandate specific training topics and procedures for Class B with Passenger Endorsement licensing. All training and

materials provided are consistent with TSI and USDOT FMCSA best practices.

A typical training day consists of both classroom and behind the wheel training as outlined in the TSI Behind the Wheel training guidelines. The ratio of trainees to instructors is no more than 1-to-4 trainees with the goal of a 1-to-2 ratio.

A series of County Connection quizzes and three written tests will be administered during the training program. Trainees are held to a passing standard of 70% on these quizzes and tests. Instructors review, individually, all incorrect answers with the trainee, and the instructor and the trainee must initial the correct answers.

Two written exams for the ELDT are also administered during the training program. Trainees are held to a passing standard of 80% per ELDT requirements. Instructors review, individually, all incorrect answers with the trainee, and the instructor and the trainee must initial the correct answers.

The exam timeline (timelines may vary):

- A. Three operational/safety quizzes within the first 40 hours of training.
- B. Three operational/safety quizzes and Test 1 between hours 40 and 80 of training.
- C. ELDT Operational Procedures and Practices Theory Assessment Exam between 40 and 80 of training.
- D. Four operational/safety quizzes and Test 2 between hours 80 and 120 of training.
- E. One operational/safety quiz, Test 3 and the Mid-term Exam will be administered between hours 120 and 160 of training.
- F. Safety Critical Knowledge and Proficiency exams are taken concurrent with the mid-term exam. The passing standard is 100% on all Safety Critical exams. Trainees will be allowed one repeat.
- G. ELDT Passenger Endorsement Procedures and Practices Theory Assessment Exam between hours 120 and 160 of training.
- H. Bus operator trainees who possess a Commercial Learner's Permit (CLP) are required to pass the DMV Employer Testing Program (ETP) Vehicle Inspection, Basic Control Skills Test and Driving Performance Evaluation Test. The passing standard for all DMV tests will be in accordance with the DMV Employer Testing Program guidelines. Testing will be administered between hours 120 and 160 of training.
- I. Bus operator trainees who possess the appropriate Class A-P/B-P Commercial Driver License (CLD) are required to pass the DMV Vehicle Inspection and Basic Control Skills test to qualify for certification by County Connection. The passing standard for all DMV tests will be in accordance with the DMV Employer Testing Program guidelines. Behind the wheel driving performance will be evaluated throughout the training program.
- J. The Final exam will be administered by or during the final week of training.

There is an accelerated training program for new hires that have previous transit driving experience. These new hires will receive up to four weeks of training. However, new hires receiving this accelerated training must pass all written tests. Training includes but is not limited to:

- Policies, Procedures, Rules, and Regulations
- Drug-Free Workplace
- Air Brakes System
- Bus Pre-Trip and Post-Trip Inspections
- Bus Maneuvers
- Defensive driving principles and techniques



- Proper positioning of the bus for Left and Right Turns
- Use of Mirrors
- Customer Relations
- Bus Accident Procedures and Reporting of Accidents
- Americans with Disabilities Act Requirements
- Fare Structure
- Communicating with Limited English Proficiency Customers
- Active Shooter Training
- De-Escalation principles and techniques

New Bus Operators must demonstrate proficiency on all vehicle sub-fleets they will operate. All classroom and behind-the-wheel training is recorded and filed on weekly training log sheets. Weekly training logs are reviewed by the department manager are transferred to a DMV Transit Driver Training Record Form DL 260, a Department of Education Training Record Form T-02 and the ELDT DMV California Commercial Driver Behind The Wheel Certification Form 1236. The manager meets with trainees midway into the training program, reviews their progress and makes recommendations as necessary. A final performance review for each new hire is conducted with the manager, or designee, before the new hire is allowed to graduate.

An instructor who is a certified DMV Examiner and in good standing with the California Employer Testing Program administers the Driver's Performance Evaluation Test following the California Department of Motor Vehicles guidelines. The test score sheets are retained as part of the driver's training record, and a DMV Certificate of Driving Skill form DL 170, is issued to the successful operator trainee. Trainees then exchange the ELDT Form 126 and DMV Form DL 170 for a Commercial Class B-P driver's license, and the DMV Form DL 260 for a Verification of Transit Training Certificate (VTT) at a local DMV office.

### **11.3 Verification of Transit Training for Bus Operators**

Experienced Bus Operators are provided annually with a minimum of 8 hours refresher training on:

- Passenger Interaction Skills
- Americans with Disabilities Act
- Approved Pre- and Post-Trip Inspection Procedures
- Vehicle Accident Reduction Skills
- Fleet Safety, Defensive Driving Skills, Railroad Crossings and Bus Stops
- Fitness for Duty
- Drug and Alcohol Testing
- Emergency Evacuation Procedures
- Active Shooter Training
- De-Escalation principles and techniques

### **11.4 Vehicle Collision Retraining**

Following a vehicle collision that the Director of Transportation has graded "preventable," Bus Operators train with a certified instructor to explore methods of preventing reoccurrence. Hours of retraining vary according to the nature of the collision. Typically, 4 to 8 hours is spent on retraining.

### **11.5 Extended Leave Training**

All Bus Operators who return to work from extended leave (more than 30 calendar day's absence, regardless of the reason for the absence) are retrained to verify the employee can perform their driving assignment to the appointed standard. Typically, up to 8 hours is spent on retraining.

### **11.5.1 Specialized Training**

Specialized training is performed on a request basis to help Bus Operators with their individual performance skills.

### **11.5.2 Vehicle Accident Reduction Program**

An ongoing program in mitigating vehicle preventable collisions consists of:

- An active ride check program to uncover deficient driving habits.
- Follow up training to address deficiencies uncovered during ride checks.

### **11.6 Safety Focus Campaign**

Utilizes posters, seat drops, PowerPoint displays and field contacts to promote safe driving and workplace practices and other management tools of the Safety Management System (SMS).

### **11.7 Data Analysis**

Analysis of collision data (preventable and non-preventable) and proactive awareness and mitigating risk through a proactive Safety Management System.

### **11.8 Mechanic Training**

New mechanics receive 280 to 320 hours of training with certified instructors, which includes:

- Policies and Procedures.
- 8 hours on forklift training and work area orientation.
- Hazardous Materials "First Responder" training pursuant to California Code of Regulations Title 8 Section 5192.
- 80 hours on vehicle orientation; driving in and around the shop area, bus stalls, and bus yard.
- 20 hours behind-the-wheel training on the road before undertaking the DMV Pre-Trip, Skills Test, and Driver's Performance Evaluation drive test.
- 80 hours mechanic training to include core elements: Shop Safety and Procedures, and Air and Brake Systems (for Mechanics I-VI).
- 40 hours training on Heating, Ventilation, Air Conditioning Systems (for Mechanics V and VI).

Mechanics who possess a Commercial Learner's Permit (CLP) are required to pass the DMV Employer Testing Program (ETP) Vehicle Inspection, Basic Control Skills Test and Driving Performance Evaluation Test. The passing standard for all DMV tests will be in accordance with the DMV Employer Testing Program guidelines. Mechanics then exchange the ELDT DMV Form 1236 and the DMV Form DL 170 for a Commercial Class B-P driver's license at a local DMV office.

Mechanics who possess the appropriate Class A-P/B-P Commercial Driver License (CLD) are required to pass the DMV Vehicle Inspection and Basic Control Skills test to qualify for certification by County Connection. The passing standard for all DMV tests will be in accordance with the DMV Employer Testing Program guidelines. Behind the wheel driving performance will be evaluated throughout the training program.

### **11.9 Bus Maintenance Training**

Upon delivery of new vehicles, mechanics undertake training provided by the vehicle manufacturer or component representative. Mechanics are selected for training based on job classification and shift coverage. County Connection contracted personnel (i.e., Transdev U.S., Inc.) also are invited to attend and participate in the equipment training.

The County Connection Maintenance training program consists of shop safety, repair skills, diesel engine tune up, basic electrical, Multiplex and charging systems, diesel electronic controls and

after-treatment, air systems and brakes, hydraulic braking systems, steering and suspension systems, automatic transmission, radio system, sub-systems, and HVAC. Classes are actively reviewed to make sure they are up to date with current fleet and industry trends.

#### **11.10 Service Worker Training**

Service Workers receive 200 hours of training with certified instructors, which include:

- 16 hours learning District policies and procedures.
- 8 hours on forklift training and work area orientation.
- 8 hours Hazardous Materials "First Responder" training pursuant to California Code of Regulations Title 8 Section 5192.
- 40 hours on vehicle orientation; driving in and around the shop area, bus stalls, and bus yard.

Service workers who possess a Commercial Learner's Permit (CLP) are required to pass the DMV Employer Testing Program (ETP) Vehicle Inspection, Basic Control Skills Test and Driving Performance Evaluation Test. The passing standard for all DMV tests will be in accordance with the DMV Employer Testing Program guidelines. Service workers then exchange the ELDT DMV Form DL 1236 and the DMV form DL 170 for a Commercial Class B-P driver's license at a local DMV field office.

Service workers who possess the appropriate Class A-P/B-P Commercial Driver License (CLD) are required to pass the DMV Vehicle Inspection and Basic Control Skills test to qualify for certification by County Connection. The passing standard for all DMV tests will be in accordance with the DMV Employer Testing Program guidelines. Behind the wheel driving performance will be evaluated throughout the training program.

#### **11.11 Verification of Transit Training**

Pursuant to California Vehicle Code Section 12804.6, eight hours of annual training is provided by County Connection certified instructors to all bus operators. Subject matter is mandated by the California Department of Motor Vehicles and is listed in section **11.3 Verification of Transit Training for Bus Operators**. Training is classroom based and can include behind the wheel training. All hours are documented on DMV Form DL 260 and DoE Form T-02.

All Operators are required to possess a valid DMV form DL 260A "California Verification of Transit Training Document" (VTT) as a requirement of employment. This is verified by a monthly license check.

#### **11.12 Certification Review/Audit**

##### **11.12.1 Pull Notice Program**

Pursuant to the State of California Vehicle Code Section 1808.1, County Connection maintains the required program elements and submits to annual inspections by the California Highway Patrol to verify compliance regarding participation in the Department of Motor Vehicles' Pull Notice Program. The purpose of this program is to enable County Connection to verify that each employee in a "Safety-Sensitive" function has a driver's license that has not been suspended or revoked, verify traffic violation point count, and whether the employee has been convicted of a violation of Section 23152 or 23153 of the California Vehicle Code. Human Resources will notify the appropriate managers of any pull notices from DMV.

### **11.12.2 Employer Testing Program**

Pursuant to the State of California Vehicle Code Section 15250, County Connection sustains all the requisite program elements, and all required records are maintained on file in the Training Department for inspection and verification. Selected County Connection instructors have participated in the DMV Commercial Driving Performance Evaluation Training. Plus, our Operations Training Department submits to annual on-site inspections and/or audits by the California Department of Motor Vehicles to verify our compliance with the DMV's Employer Testing Program (ETP). The DMV inspection can consist of examination of records such as the DMV Form DL 65 ETP Part I "ETP CDL Pre-Trip Inspection and Skills Evaluation Score Sheet" and DMV Form DL 65 ETP Part II "ETP CDL Driving Performance Evaluation Score Sheet."

### **11.13 Human Resources Training**

#### **11.13.1 Training Policy Established**

Human Resources has established policies that cover the following:

- Training enrollment
- Travel authorization – for training
- Pay during travel and training
- Tuition reimbursement
- Performance management

#### **11.13.2 New Hires / Contractors / Vendors**

- New Hire Orientation – All employees, including Operators, receive 6 hours of employee orientation upon hire. Topics covered are Information Systems Orientation, Time and Labor, Employee Relations Orientation, and Human Resources Policies and Procedures.
- Contractors/Consultants – Occasionally we have no contractors providing training at County Connection.
- Vendors – Currently employees can apply to external vendor training providers to take training upon approval of manager and Human Resources.
- Training – County Connection also registers employees in workshops that are offered to employees for a fee. County Connection employees can also participate, upon approval of their supervisor, in external vendor training or certification programs through the County Connection continuing education program.

#### **11.13.3 On-the-Job Training**

Human Resources encourages departments to utilize on-the-job training. All supervisors and employees are encouraged to hold a Career Discussion. The manager is available for employee development consulting.

#### **11.13.4 Coordination of Inter-Departmental Safety Record Training**

County Connection has mandatory safety and security training for employees.

#### **11.13.5 Computer-based Training**

We currently have an online training vendor to provide Sexual Harassment training as mandated by the State of California every two years for managers.

Employees requiring computer-based skills training, e.g., MS Office Suite – Word, Excel, etc., are encouraged to attend external training resources or to attend internal workshops.

### **11.13.6 Training Tracking**

We currently do not have a training system that would automatically assign or track completed training at County Connection.

### **11.13.7 Vendor Training Evaluation**

Final evaluations on workshops are collected and provided to external vendors or internal trainers as a way to track overall satisfaction by participants.

## **12 EMERGENCY RESPONSE PLANNING, COORDINATION, TRAINING**

### **12.1 Emergency Conditions**

Abnormal and emergency conditions may develop that interfere with efficient passenger movement. An emergency may involve fire, smoke, collision, power failure, structural damage to facilities or infrastructure, or other circumstances.

### **12.2 Emergency Procedures**

Procedures have been developed and incorporated into the Emergency Plan, which is located in Director's offices and the Facility Maintenance office, and the Operator Rulebook and other documents for the safety of passengers during an emergency event.

### **12.3 Emergency Management Program Activities**

The Emergency Plan details emergency planning, preparedness, and response capabilities. The Chief Safety Officer is responsible for the periodic review of this plan and emergency procedures with all affected departments and external agencies, as appropriate, and as required as a result of evaluations of drills and actual incidents.

Both Operations and Maintenance have been prepared to continue services for light search and rescue and First Aid supplies even after the main buildings sustain heavy damage. The trailers are equipped with a generator capable of providing alternative power in the event of electrical failure. See Section 8 (Facilities Inspections) of this document for a listing and inspection schedule of the types of equipment and capabilities County Connection maintains.

Dispatch vehicles have installed Ethernet WiFi to stay in connection with the fleet through mobile laptop.

The Emergency Plan contains instructions on what do to in case of an earthquake. There's a section for All Employees and a section for Dispatch providing instructions for how to respond during an emergency, as well as emergency telephone numbers and logs for tracking equipment and personnel. There is Emergency Preparedness outlining operational aftermath procedures in the event of a large-scale disaster.

### **12.4 Fixed-Route and Paratransit Contractors**

The Contractor providing Paratransit services on behalf of County Connection is required to follow prescribed emergency response procedures specified in their respective Scopes of Work. In case of emergencies, all vehicles carry onboard a copy of "Emergency Preparedness" instructions. Operators ensure its presence via their daily pre-trip inspections. Operators are instructed to follow these instructions and report their status via two-way radio or phone communication. Dispatchers report and receive instructions from the Paratransit Department who is part of County Connection's Emergency Operations Center (EOC) structure.

## **12.5 Mutual Aid Agreement**

County Connection participates in a Mutual Aid Agreement, which has been made among transit agencies in the Bay Area through the Metropolitan Transportation Commission (MTC).

## **12.6 Emergency Drills and Exercise**

Emergency preparedness drills are planned and conducted to ensure the:

- Adequacy of emergency plans and procedures
- Readiness of personnel to perform under emergency conditions
- Effective coordination between emergency response agencies

County Connection is a member of the MTC Transit Response Planning Committee for the purpose of contributing to the planning and taking part in the execution of the MTC Training and Exercise Plan. The Training and Exercise Plan is administered by MTC in conjunction with Bay Area transit operators, California Office of Emergency Services, California Department of Transportation, and San Francisco Bay Area Water Emergency Transportation Authority. All exercises referenced in the Training and Exercise Plan and coordinated by MTC will meet minimum Homeland Security Exercise and Evaluation Program requirements and comply with both Federal Emergency Management Agency guidelines and the National Incident Management System.

## **12.7 Alternative Emergency Communication**

The MTC has set up a satellite phone system to be used throughout the San Francisco Bay Area in the event of an emergency, such as an earthquake. There is a test of the system on the first Wednesday of each month. Participants in the system include Bay Area Counties Office of Emergency Services, public transit districts, the California Highway Patrol, and the MTC. Each year the MTC also distributes the participating organization list, which includes a contact name, office phone number, email address, and satellite identification number. The satellite phone test is conducted at 9:15 a.m. on the first Wednesday of each month. MTC will lead the call, with Bay Area Rapid Transit (BART) police department as a backup.

## **12.8 Coordination with External Emergency Agencies**

The Safety Department serves as the liaison between police and fire jurisdictions and emergency response agencies. The Chief Operating Officer serves as the liaison with law enforcement agencies.

## **13 SYSTEM MODIFICATION DESIGN REVIEW AND APPROVAL PROCESS**

Transit systems are in a constant state of acquisition, with new equipment, system expansion and modification, and system rehabilitation requiring constant design and procurement efforts. Ongoing acquisitions and procurement can be more critical than initial design for many reasons. Coordination and compatibility with the existing system, construction efforts under operating conditions and testing and break-in phases must all be managed as part of the ongoing system safety effort. Equally important is the Safety Certification process, a detailed, documented approval process with specifics of sign-off requirements and exception capability.

County Connection utilizes professional consulting services (e.g., general engineering contractor) to provide design of system modifications including various optional solutions. An internal technical review panel made up of a variety of staff as appropriate, provide review of the designs and recommend approval through the necessary processes. A contractor(s) is hired through the contract and procurement process and the project is managed, through acceptable completion, by the Facility Maintenance Department.

### **13.1 System Modification to Equipment or Stock**

Changes to equipment and stock are forwarded by the Director of Maintenance to the Chief Operating Officer for authorization. Campaign Bulletins communicate such changes to Maintenance personnel. Complex design changes such as electrical or structural, come from the original equipment manufacturer (OEM). County Connection relies on the OEM engineer(s) for review of such design changes prior to authorization of the Chief Operating Officer.

### **13.2 Safety Certification of Stock**

Bus acceptance procedures are part of the new bus procurement. The responsibility of project management for all stock will be the Chief Operating Officer, or their designee, and occur in the approximate following order:

- Pre-built meetings between the OEM, bus maintenance contract administrator, and Chief Operating Officer occur after award of contract.
- As part of the procurement process for electric buses, the Chief Operating Officer coordinates and plans the charging infrastructure needs and requirements with the Facilities Superintendent. This coordination includes power requirements, sign assessment and existing infrastructure viability, charger requirements, and an operational charging management plan.
- Onsite "live production" inspections occur on the OEM's premises with sign-off by the Director of Maintenance.
- The Chief Operating Officer is responsible for including the Operations Training Department in the review of the operating characteristics of the new buses (e.g., dash layout, mirror positioning, and location of controls).
- Upon delivery of new buses to County Connection, there is an acceptance procedures inspection with the OEM and a defect list is created.
- For electric buses, bus chargers include a separate acceptance procedure. For electric buses, the charging infrastructure testing and operational functionality include oversight from the Maintenance and Facility Maintenance Departments, OEMs, power providers, and third-party contract specialists.
- Preparation for revenue service and in-house retrofit/modifications (e.g., programming, fareboxes, and system).
- The OEM provides signoff on brakes. The Director of Maintenance will validate such signoffs.
- Technical training supplied by both the OEM and the bus manufacturer (e.g., buses by Gillig, transmission by Voith, air conditioning by Thermo King, diesel engine by Cummins).
- Operations training personnel attend "Train-the-Trainer" training.
- Ready for revenue service.
- In-house training for Maintenance mechanics.

### **13.3 System Modification to Facilities**

The Facilities Maintenance Department manages major facility improvement projects, from the earliest planning phase through the design and construction phases. Good design and construction planning require coordinated reviews from the user departments, including Maintenance, Transportation, and Safety. On large or more complex projects, consulting engineer and architects who provide professional design and construction services assist the project manager. Major projects, such as the electrification of the bus fleet, are reviewed and approved by the local planning, building and fire departments.

## **14 SAFETY DATA ACQUISITION/ANALYSIS**

One of the most important services the Safety Department provides for County Connection is the collection, maintenance, and distribution of safety data relative to system operations. This data includes information gathered from within the system on various operating events relative to safety.

Analysis of this system specific data can be used to determine trends and patterns in system operation. Used as part of the hazard resolution process, data collection and analysis can be used to identify hazards before they cause accidents by such techniques as trend analysis, and thus becomes a vital component of effort to improve system performance not only in respect to safety, but also in overall delivery of service to the riding public.

#### **14.1 Executive Summary Report**

Lists the following information:

##### **14.1.1 Vehicle Accidents**

- Running totals and subtotals of all accidents and preventable accidents for the current calendar year and each of the previous two years, broken down by Transportation and Maintenance.
- A descriptive paragraph describing the categories of preventable accidents for the current month the report was issued.
- The average number of miles traveled between preventable accidents.
- A description of all preventable and non-preventable accidents based on type of accident broken down by the current year and each of the previous three calendar years.
- A description of the current month's preventable accidents broken down by employee type (operator, maintenance, other) and place of origin.
- A description of all preventable accidents during the current month broken down by days of the week they occurred.
- A description of all preventable accidents broken down by month of occurrence for the current calendar year and each of the previous three years.
- A description of the percent change on a monthly basis of the year-to-date preventable accident totals for the current year as compared to the previous calendar year.

#### **14.2 Preventable and Non-Preventable Accidents Reports**

This report shows all preventable and non-preventable accidents for each individual bus operator and maintenance employee for the previous 24 months from the date of the report and the date of the last preventable and non-preventable accident prior to the two-year reporting period.

#### **14.3 Passenger Falls Report**

This report lists the following information for each passenger fall from the current month, the previous months of the current calendar year and the previous calendar year:

- Name of Operator
- Date of fall
- Fall type
- Bus number
- Route
- Base of origin

### **15 INTER-DEPARTMENTAL/INTER-AGENCY COORDINATION**

Communication between departments is conducted primarily through staff meetings, memorandums, emails, and topic specific task forces.

To date, we have worked with every department across the organization to create detailed organizational charts to help people identify position specific roles and responsibilities. These organizational charts are intended to be used as a quick reference to help individuals find the right person to discuss business related questions.



Emergency Response Agency coordination is discussed in full in Section 12 (Emergency Response, Planning, Coordination, Training) of this document. See also Section 13 (System Modification Design Review and Approval Process) of this document.

## **15.1 Director and Manager Positions**

### Assistant General Manager – Administration, Ruby Horta

Purpose: Provide leadership to the Administration Department and directs its activities to realize County Connection's goals and objectives as they relate to the functions of human resources, marketing and customer service, management information systems, and service planning and ADA/Specialized Services.

### Chief Operating Officer, J. Scott Mitchell

Purpose: Provide leadership to the Transportation and Maintenance Department's functions such that County Connection's goals and objectives, as they relate to the functions of transportation, equipment and facilities maintenance, stores and procurement.

### Chief Financial Officer, Amber Johnson

Purpose: Provide leadership to the Finance Department's functions such that County Connection's goals and objectives, as they relate to financial activities, can be realized.

### Director of Transportation, Yvette Glenn

Purpose: Provide leadership to the Transportation Department's activities such that County Connection's goals and objectives, as they relate to transportation activities to ensure quality service and service delivery.

### Director of Human Resources, Dawud Brewer

Purpose: Plans and carries out policies relating to all phases of human resources activity by performing the following duties personally or through subordinate supervisors.

### Director of Planning & Marketing & Innovation, Melody Reeb

Purpose: Responsible for the development of innovative strategies to utilize emerging technologies and innovations in the transportation industry to provide safe, efficient and accessible transportation services.

### Director of Maintenance, Marcel Longmire

Purpose: Provide leadership to the Maintenance Department and direct its activities to realize County Connection's goals and objectives as they relate to the functions of effective maintenance services on County Connection vehicles.

### Director of IT, Chan Saechao

Purpose: Directs and coordinates activities of workers engaged in computer operations. To act as a technical, analytical, administrative, and managing resource to the IT, Scheduling, and Service Analysis sections such that the department's goals and objectives can be realized.

### Manager of Human Resources, Kristina Martinez

Purpose: Provide management and leadership in activities as they relate to recruitment, performance management, employee development and other special programs.

### Director of ADA and Specialized Services, John Sanderson

Purpose: Manages service contracts within the guidelines set forth by the Board of Directors and state/federal law. Manages day-to-day operations and performance of through contract monitoring.

Manager of Accessible Services, Rosa Noya

Manager of Accounting, Karol McCarty

Purpose: Responsible for all areas relating to financial reporting. This position is responsible for developing and maintaining accounting principles, practices and procedures to ensure accurate and timely financial statements.

Manager of Training, Sophia Martinez-Morris

Purpose: The Training Manager is responsible for proper training of designated employees, developing, establishing and promoting the maintenance of a safe, accident free and healthy working environment.

Manager of Transportation, Aline Carroll and Miguel Duenas

Purpose: Manages and coordinates the Transportation Department's activities, as directed by the Director of Transportation, such that the department's goals and objectives can be realized.

Manager of Marketing & Communications, Ryan Jones

Purpose: Responsible for oversight and development of County Connection's marketing, public information, customer service, and outreach programs and activities.

Manager of Planning, Pranjal Dixit

Purpose: Assists in the development of innovative strategies to utilize emerging technologies and innovations in the transportation industry. Provides management support to customer service and marketing personnel.

Chief Service Scheduler, Don Avelar

Purpose: Responsible for oversight and development of County Connection's long range, short range, and capital planning, provision of technical, analytical and management support to the Scheduling section of Operations, and supervision of data analysis personnel enable County Connection to provide quality transit service, which responds to community and passenger needs.

Facilities Superintendent, Steve Muhlestein

Purpose: Under general direction of the Chief Operating Officer, plans, directs and performs the maintenance and repair of assigned County Connection facilities and equipment, supervises department employees.

Manager of Maintenance, Bruce Voltz

Purpose: Under the general direction of the Director of Maintenance and Chief Operating Officer, this position plans, organizes, directs, and coordinates the activities of Mechanics and Service Workers to ensure efficient, safe, secure and effective maintenance services.

Manager of Grants and Purchasing, Kevin Finn

Purpose: Plans, manages and coordinates the purchase of materials, equipment and services for County Connection. Supervises Purchasing and Materials Department. Manages disbursements of Grants and Grant Reporting Requirements. Writes and manages Request for Proposals and contracts.

## **16 CONFIGURATION MANAGEMENT**

Managing all components of the County Connection system including hardware, software, rules, procedures, training programs, information and documentation related to infrastructure, facilities, equipment and operations and maintenance to ensure that they possess the required safety characteristics and that documentation reflects those characteristics accurately.

Configuration management is the process that ensures, as much as possible, that all property, equipment, and systems design elements are documented as to configuration, accurately and completely. That any changes to an individual subsystem, or a fleet- or inventory-side change is recorded on as-built drawings and addressed in training courses, maintenance manuals and procedures in a timely and effective manner. The process includes procedures for authority to make configuration changes, the process for incorporating these changes into all appropriate documentation and the process for ensuring that all necessary units are formally made aware of such changes.

### **16.1 Configuration Management of Equipment and Stock (Reference Section 5.1.5 System Modifications)**

- Vehicle acceptance originates in Maintenance. The Maintenance Department will document and maintain all records related to the useful life cycle of all equipment and stock and will also provide oversight to any changes that fall within the scope of the program.
- As-built documents are filed in Maintenance Department. All modifications are documented.
- All modifications are properly documented and available to all personnel supporting maintenance and repair.
- New County Connection assets arrive in a quality status that is documented and prearranged.
- Campaign Bulletins originate in Maintenance to document equipment changes, modifications or adjustments. Campaign Bulletins are forwarded by the Director of Maintenance to be approved for issuance by the Chief Operating Officer.
- Service Bulletins document maintenance procedures, inspections or maintenance service. Their content is originated by the original equipment manufacturer to address specific subsystem issues. Availability to review changes in configuration for any and all providers of asset maintenance.
- Technical Bulletins make adjustments to Maintenance procedures.

### **16.2 Configuration Management of Facilities**

The Chief Operating Officer is responsible for all new construction projects and facility improvements. The Facility Superintendent is responsible for all associated support equipment and owned facilities, which include all building structures, plumbing, electrical, heating and air conditioning, pavement, lighting, parking, bus fueling facility, and bus wash. All functional areas coordinate with all other departments to emphasize acceptable levels of safety in the design or new equipment, facilities, and construction specifications.

## **17 EMPLOYEE SAFETY PROGRAM**

Incorporated herein specifically by portion and by overall reference, this program manual outlines the policies, objectives, responsibilities, investigative procedures, communications policies, and all safety, hazard and occupational injury and illness report forms and includes the following articles:

### **17.1 Safety Procedures/Requirements**

- Service Support Vehicle Requirements – Reporting Accidents and Qualified Drivers
- Reporting Revenue Vehicle Accidents
- No-Smoking Regulations

- Reporting Occupational Injuries/Illnesses
- Hazard Communication
- Portable Fire Extinguishers
- Bloodborne Pathogens
- Emergency Action Plan
- Injury & Illness Prevention Program
- Ergonomics
- Supervisor/Manager Responsibilities in Health & Safety
- First Aid Kits and Automated External Defibrillators (AEDs)

## **17.2 Incentive Programs**

To begin in 2023:

- Safe Driver Award Program – Bus Transportation
- Safe Worker Award Program – Bus Maintenance

The department standard operating procedures for vehicular collision/accident investigations are documented in Section 7 (Accident/Incident Reporting & Investigation) of this document.

## **18 HAZARDOUS MATERIALS PROGRAMS**

County Connection operates a facility that is required to maintain environmental permits. Section 5.1.3 (Facility, Bus Shelters and Stops) of this document describes this facility in detail.

County Connection complies with all current regulations for the storage, handling and disposal of hazardous materials through trained facility staff and a licensed hazardous materials contractor. Specifically, the Facilities Department handles disposal of used batteries and fluorescent lights.

For the safety of our employees, copies of the Safety Data Sheets (SDS) for all our regulated materials in use at County Connection are maintained by the Facility Maintenance Department and are available to all employees.

The permit documents County Connection is required to maintain with regard to the storage of regulated materials are the “California Hazardous Materials Inventory Reporting Form” (i.e., Hazardous Materials Business Plan), and the “Spill Prevention Control and Countermeasure Plan” (SPCC).

Storage of hazardous materials is regulated and monitored by Contra Costa Health Services, Department of Environmental Health & Hazardous Materials Programs.

The documentation for the “Annual Report for Storm Water Discharges Associated with Industrial Activities” and the “Storm Water Pollution Prevention Plan” (SWPPP) make up our “General Industrial Activities Storm Water Permit.” This documentation is submitted to the California State Water Resource Control Board.

## **19 DRUG AND ALCOHOL ABUSE PROGRAMS**

County Connection has a strong commitment to all employees to establish programs promoting high standards of responsibility to the public and reliable performance. We are committed to providing an alcohol and drug-free workplace, to provide a safe and productive work environment, and to maintain the public’s trust and confidence in our transportation services. The purposes of these programs are to help prevent accidents, injuries, incidents, and losses resulting from alcohol and drug issues. County Connection also provides an Employee Assistance Program and

encourages employees to seek professional assistance anytime personal problems, including alcohol or drug dependency could adversely affect their ability to perform their assigned duties or endanger their coworkers.

Pursuant to Title 41 United States Code Section 701 et. Seq., The Drug-Free Workplace Act of 1988 and Title 49 Code of Federal Regulations Part 655, Prevention of Alcohol Misuse and Prohibited Drug Use in Transit Operations, County Connection has developed Section 209 (Substance Abuse Program) in the Employee's Handbook. The administration and maintenance program requirements for this program is handled by the Human Resources Department.

## **20 CONTRACTOR SAFETY COORDINATION**

### **20.1 Fixed Route and Paratransit Contractor Oversight**

Contractors providing services for County Connection must follow the safety rules, procedures and directions outlined in the PTASP document. To ensure the contractors understanding and to demonstrate their commitment to the PTASP, the contractor (Transdev U.S., Inc.) has become a signatory to the PTASP.

Transdev U.S., Inc. ensures the assets are receiving timely and proper maintenance. Ratings include defects based on eighteen (18) categories rated "A" for major concerns requiring immediate attention and rated "B" for defects that do not require immediate attention; both are averaged and compared to previous inspections to gauge the contractor's maintenance schedule adherence. In addition, engine oil transmission and coolant fluid samples are taken and analyzed to ensure that engines are running at their best. The information is compiled into a formalized report that details the findings and compares stats with past audits. The report is sent to Transdev U.S., Inc. for review and then forwarded to the Chief Operating Officer for review.

As contractors are on-site at County Connection facility performing work, County Connection staff monitors their schedule (check-in and check-out), ensures proper identification (badges, uniforms, etc.) are in place, and performs a safety briefing to monitor their work through completion with Maintenance Department staff. Contractor's insurance is verified through County Connection's contracts and procurement staff.

The Maintenance staff performs semi-annual inspections of the operations of the Contractor during County Connections inspections. The Director of Maintenance or their designee performs an onsite review of maintenance records and vehicle condition inspections. Audits are conducted per the contractual stipulations. A report is compiled and submitted to the Chief Operating Officer for review.

Contracted Services are monitored by our Director of Accessible Services regarding the performance of contracted shuttles and paratransit services throughout the service area. The manager assists with analysis and evaluation of inspection data and contractor-prepared reports and provides information relative to observed or anticipated difficulties in meeting contractual goals and performance standards.

In addition, staff meets with the Contractor on a month or bi-weekly schedule to review performance and compare contract stipulations. Operational issues are also covered. Contracts staff provides suggestions and recommendations to help alleviate any concerns at hand.

Staff also monitor customer complaints. Staff also periodically travels to locations and conducts assessments for safety and usability. A response is generated once inter-departmental consensus is reached as to who the appropriate respondent should be.

### **20.1.1 Paratransit Service**

In January 1990, County Connection assumed responsibility for Public Paratransit Service in Central Contra Costa. County Connection provides service for passengers with mobility impairments through a contract with Transdev U.S., Inc. The Contractor provides curb-to-curb service, as well as limited door-to-door service, seven (7) days a week. Individual trips are scheduled up to seven days in advance in accordance with ADA regulations. Annual operator/vehicle records and vehicle inspections for the service provider fall under the California Highway Patrol (CHP). Staff review the CHP terminal inspection reports after each completed inspection.

### **20.2 Fixed Route and Paratransit Contractors**

County Connection currently provides an in-person eligibility process procedure for ADA paratransit service. At this time the number of registered ADA clients in Central Contra Costa County is 4,545.

The Contractor providing purchased transportation on behalf of County Connection is required to follow Emergency Response procedures specified in their respective Scopes of Work. In case of emergencies, all employees adhere to "Emergency Preparedness" instructions. Operators ensure its presence via their daily pre-trip inspections. Operators are instructed to follow these instructions and report their status via two-way radio or phone communication. Dispatchers report and receive communication from Paratransit, which is part of County Connection's Emergency Operations Center (EOC) structure. Every six (6) months, the Director of Maintenance conducts a series of inspections of contracted services.

### **20.3 Capital Projects and Construction Contractor Safety**

County Connection's construction contracts include standard general conditions and special provisions that outline requirements for the following:

- Supervision and construction procedures
- Permits and licenses
- Oversight by the Contractor
- Construction schedule
- Work site maintenance
- Access to the work sites
- Subsurface excavations
- Trench excavation safety plan
- Hazardous chemical and wastes
- Public safety
- Emergencies

## **21 CONSTRUCTION SAFETY REQUIREMENTS**

### **21.1 Description**

- A. This Section includes specifications for construction safety requirements. In addition to these requirements, the Contractor shall comply with Federal and State OSHA, ANSI and all other applicable safety standards. When a discrepancy exists, the more restrictive requirement shall apply.
- B. Satisfactory performance under this specification will not relieve the Contractor of responsibility for safety.

The Contractor and/or subcontractor(s) shall at all times observe safe practices and comply with applicable codes, rules and regulations of Federal, State and local agencies having jurisdiction. The Contractor shall ensure that service technicians are properly trained and equipped to safely perform contract work and act in compliance to Contractor's Injury & Illness Prevention Program (IIPP), Code of Safe Practices, and Contractor's project related work safety manual/documents.

## **21.2 Safety Requirements and Deliverables**

- A. The Contractor shall furnish a copy of firm's Injury & Illness Prevention Program (IIPP) pursuant to OSHA standards and California Code of Regulations, reference CCR, Title 8, Section 3203. This document may be furnished in print or electronic (PDF) format and shall be provided in advance of County Connection's Notice to Proceed.

The required elements of the IIPP program are:

1. Responsibility
  2. Compliance
  3. Communication
  4. Hazard Assessment
  5. Accident/Exposure Investigation
  6. Hazard Correction
  7. Training and Instruction
  8. Recordkeeping
- B. The Contractor shall provide a safe work area for its employees and those of County Connection. When unsafe conditions do exist, immediate corrective action(s) and preventive measures are required. The Contractor shall furnish a copy of firm's Code of Safe Practices pursuant to California Code of Regulations, Title 8, Section 1509. This document may be furnished in print or electronic (PDF) format and shall be provided in advance of County Connection's Notice to Proceed.

## **21.3 First Aid and Worker Safety**

- A. Employees shall receive prompt first aid care when injured.
- B. The Contractor shall provide employees with applicable First Aid and Personal Protective Equipment (PPE) supplies and related training.
- C. Contractor's personnel shall utilize PPE, which may include, but not be limited to, the following:
1. Safety hard hats
  2. Safety hearing protection
  3. Safety eye protection
  4. Safety shoes
  5. Respiratory protection

## **21.4 Emergencies and Emergency Procedures**

- A. In the event of an emergency, Contractor's IIPP will include the following procedures:

1. Identify the person responsible for handling an emergency.
  2. Establish teams for handling each type of emergency.
  3. Identify the person responsible for making emergency calls (preferably the ranking supervisor present).
  4. Require conspicuously posted list of emergency phone numbers, along with information to be transmitted.
- B. Following an emergency, the Contractor shall:
1. Secure the area as expediently as possible.
  2. Contact County Connection's Facilities Superintendent immediately.
  3. Provide to County Connection's Facilities Superintendent, and to applicable agencies, an account of the nature of the emergency.

### **21.5 Specific Requirements**

- A. **Work Practices:** The Contractor shall be responsible for employees working safely and use the appropriate personal protective equipment. A qualified supervisor/worker shall monitor work conditions and conduct daily safety briefings, which are to be documented daily and shall be provided upon request to a County Connection designee. This applies equally to applicable subcontractor(s) as utilized by the Contractor.
- B. **Work Areas:** Upon arrival to County Connection's facilities, Contractor's personnel shall inspect the immediate job site to recognize and eliminate jobsite hazards and unsafe conditions. As needed, applicable traffic-control devices shall be utilized in accordance with federal, state, and local regulations to regulate, warn, and guide traffic at work site.
- C. **Accident Investigations:** The Contractor shall conduct an accident investigation whenever an accident or near miss, with major potential for a loss, occurs at County Connection facilities and/or upon request by County Connection. Relative data regarding each incident shall be compiled on forms and completed within 24 hours. The forms shall provide verification of related facts and be accompanied by recommendations noting specific corrective action(s) and preventive measures to preclude the occurrence of similar accidents/incidents. Copies shall be submitted to County Connection's Facilities Superintendent.
- D. **Record Keeping and Reporting:**
1. Maintain an injury and illness log with accurate monthly man-hours.
  2. Obtain the same log and form from all subcontractors.
  3. Upon request from County Connection, the Contractor shall document its periodic employee Safety Meetings pursuant to the IIPP. Contractors shall record/document the meeting dates, topics, employee attendance and any subsequent action(s) to address safe workplace practices and requirements.
- E. **Electrical Work:**
1. The Contractor's employees shall have a lockout/tagout program in writing and implemented procedure for eliminating risk of hazardous energy sources.



2. All Contractor's electrical equipment and related wiring, connections and/or hook-ups, shall be in accordance with the NFPA 70 and California Building Standards Title 24, Part 3.
3. The Contractor's employees shall conduct applicable equipment-grounding conductor procedures that meet NEC requirements

## **22 PROCUREMENT**

System safety extends to include the routine procurement of supplies, materials, and equipment. Within County Connection procedures are in place to preclude the introduction into the transit environment of unauthorized hazardous materials and supplies, as well as defective or deficient equipment and replacement parts.

### **22.1 Maintenance Contract Administrator**

It is the responsibility of the Chief Operating Officer to develop the technical specifications and contract documents for the materials and services required to support the Maintenance Department's Capital and Operating budget programs. Specifically, this position:

- Writes/reviews technical specifications for bus equipment, purchased or to be purchased, on contracts funded by capital grants.
- Works with capital administration, contracts and procurement, Operations and Maintenance personnel, Operations training, and the Safety Committee to ensure that technical specifications for contracts are adequate, responsive, and correct.
- Develops technical provisions and warranty specification in accordance with Federal, State and local laws and County Connection policies.
- Administers quality assurance program.
- Acts as liaison to contract vendors, engineering and other staff elements for capital purchases such as bus equipment, alternative fuels, and radio configuration equipment.
- Monitors vendors to ensure compliance with contracts and agreements.
- Compose, update, and research technical bulletins, campaign bulletins, and standard operating procedures to improve quality of service on capital equipment related items.

### **22.2 Warranty Administrator**

Maintenance management is responsible for the Maintenance Department's quality assurance and warranty activities as related to the procurement of replacement parts, services, and equipment; and the internal/external repair practices/procedures in the maintenance of heavy-duty transit buses and support vehicles/equipment. Specifically, this position:

- Plans, organizes, and coordinates the Warranty Control Program.
- Develops, implements, and administers a Quality Insurance Program to be used in the procurement of replacement parts, services, and equipment.
- Reviews for approval, new products and parts for "Approved Equal" status assuring minimum quality standards are maintained. Initiates and monitors in-use testing, if required, as a method of determination.
- Coordinates failure analysis of parts and/or equipment under warranty. Advises management of trends or unsafe conditions and recommends corrective action.
- Monitors vendors to ensure compliance with warranty agreements.
- Acts as liaison to external vendors, manufacturers, technical engineers and others.

## **23 ALTERNATIVE FUELS & SAFETY**

County Connection is an active participant in the procurement and operation of zero emission buses. County Connection is committed to evaluate the best possible technology that will provide performance, reliability, cost effectiveness, and cleaner emissions. With new developments and ever-increasing research, County Connection is well positioned to take advantage of the next

evolution of technology.

In 2009, nine diesel-hybrid buses were placed into service. In combination with the diesel-hybrid buses, clean diesel buses have reduced fuel consumption, noise, and greenhouse gases. In 2016, County Connection purchased four electric buses. In 2017, four more electric buses were added to the fleet. The electric buses have a range of approximately 180 miles and have charging stations at the Walnut Creek BART station and the facility. Due to the high voltage, unique personal protective equipment is required. Original equipment manufacturer requirements and procedures for charging and maintaining these buses are designed and installed.

## **24 OPERATING ENVIRONMENT AND PASSENGER FACILITY MANAGEMENT**

Bus stop planning and design is a joint effort of Planning, Transportation, Maintenance, and other local public agencies. Elements considered during the planning, design and construction phases include location, spacing, site planning, sidewalk, landing pads, bus stop length, shelters, benches, lighting, amenities, signing, traffic engineering, turnouts, roadway design, property encroachments, and ADA requirements.

To provide for a safe operating environment for both our buses and customers when planning locations for bus stops and passenger amenities, County Connection has Orange County Transportation Authority's OCTA Bus Stop Safety and Design Guidelines.

Shelters are primarily located at transfer points, shopping centers, hospitals, BART stations, and park and ride lots. County Connection works with the local jurisdictions to identify locations for shelters and benches based on a variety of factors such as boarding activity, right-of-way availability, and passenger requests. There are 116 free standing benches system wide. County Connection maintains 1,288 bus stops. Passenger shelters are provided at 164 bus stops in the County District. Many of these shelters are maintained by Outfront Media, which places ads in them, as well as maintains them. Repairs to shelters are performed by Facility Maintenance in an emergency only.

## **25 SECURITY**

It is the objective of County Connection to provide secure and reliable service to its passengers, minimizing vandalism and property destruction associated with County Connection's vehicles and facilities, and provide a safe and secure workplace for employees.

### ***System Security Program Plan Preparedness Plan (SSEPP)***

The SSEPP was a prevention-oriented approach to security emphasizing the importance of identifying potential threats and areas of vulnerability, developing approaches that will minimize those threats and vulnerabilities, and demonstrating a clear and pro-active approach to security.

The SSEPP was replaced with a *System Security Plan (SSP)*. The SSEPP contained classified "Sensitive Security Information" (SSI), and therefore cannot be shared openly with every employee and contractor, yet it contained non-security information that everyone should have access to. County Connection adopted an "SSI" policy and instituted an SSI program explaining what SSI is, who is responsible for the program and how to gain access to any SSI document.

County Connection maintains a contract with Guardian Security Agency. They provide services including but not limited to:

- Patrol services for up to 24 hours a day 365 days year.
- All management oversight associated with providing security enforcement services.
- All activities associated with personnel.

- Response to high priority calls for service.
- Conduct investigations.
- Maintenance of all records, reports, and required/related documents.
- Maintenance and management of the property/evidence function.
- Fulfill duties and responsibilities.
- Select, train and obtain the necessary certification for security use of single purpose duties.

Except as otherwise specifically set forth in the Agreement, the services shall only encompass the duties and functions of the type coming within the jurisdiction of and customarily rendered by the statutes of the State of California and the regulations adopted by County Connection and Board of Supervisors.

## **25.1 Information Technology (IT)**

IT staff secures the camera system and badge system. They also produce badges for all employees and contractors.

### **25.1.1 Payment Card Industry (PCI) Compliance**

County Connection is currently compliant with Payment Card Industry-Data Security Standard (PCI DSS) 3.1. Information security standards are designed to ensure that we maintain a secure environment to process and store information.

- Clipper Card system used at BART and buses can add money from a bank card through a card reader to the server using WiFi.
- Vulnerability scans and bi-annual penetration test.
- There are application, database, and file system backups (two on site). One backup is Amazon cloud AWS.
- Data retention and protection.
- Good Mobile Messaging for containing corporate information on smartphones.
- Call recording.
- Badging system updated November 2019. BRIVO is the name of the hardware.
- Wide Area Network used for Closed Circuit Television feeds from various areas.
- Automatic Vehicle Location (AVL) – Maintain IT security and infrastructure for AVL.
- Securities vulnerabilities – Regular notifications and other sources are received and reviewed; corrective/preventive actions are taken as needed.
- Disaster recovery.
- Disaster recovery for Exchange server to prevent single point of failure.
- Backups are replicated to disaster recovery site to prevent any data corruption or in case of any disaster at the office.

### **25.1.2 Network**

- Defense in depth – Multiple layers of security control for critical systems access control lists.
- Perimeter security.
- Access control server – Access control management and compliance.
- Outlook email – Email security appliance provides advanced threat prevention, blocks spam and viruses, and enables corporate email policy enforcement.
- Amazon Web – Web security appliance, URL filtering and reputation filtering.
- Emergency Responder Mitel system and its enhanced 911 functionality.

## **26 INTERNAL SAFETY AUDIT, CONTROL AND UPDATE PROCEDURES**

The internal safety audit program determines compliance with County Connection's safety policies, rules, regulations, standards, codes, procedures and assigned system safety activities

and requirements as prescribed within the Public Transportation Agency Safety Plan (PTASP). The details below are included in the "Internal Public Transportation Agency Safety Plan Audit Procedures."

The Accountable Executive must ensure all 26 elements of the PTASP are audited at least once every year. Or, if an accident/incident occurs, a document review may be done.

A meeting with management of the department to be audited and the Accountable Executive will occur prior to the audit being conducted so that audit expectations are known, and the department management is aware of the criteria of the audit.

### **26.1 Internal Safety Audit Process**

The Accountable Executive has established an internal safety and audit program to measure the effectiveness of the PTASP in achieving the objectives of the Plan and compliance with its requirements. Program requirements include the following:

- A process to ensure adequate on-the-job safety surveillance during system maintenance, operation, and modification.
- A process to determine compliance with management safety policies as contained in PTASP.
- A process to determine compliance with operating rules, regulations, standards, codes, and procedures.
- A process to recommend specific corrective action plans to eliminate or minimize the effects of any deviations from compliance.
- A process to audit design process for future construction.

### **26.2 Audit Responsibility**

The Accountable Executive is responsible for ensuring that the required audits are conducted. This preserves the independent nature of the audit process since other organizational units are primarily involved with implementation of the audit items. Other organizational units are required to cooperate with the Accountable Executive in the conduct of audits.

### **26.3 Audit Schedule**

Audits will be announced in advance by the Accountable Executive to ensure the full support and participation of each department. An audit will be conducted at least every year, or more often as required. The audit may include the use of unannounced inspections and spot audits as determined by the Accountable Executive. Spot audits will be an ongoing part of the audit program.

### **26.4 Audit Content**

The Accountable Executive will cause the following functions to be addressed in the audit:

- Facility inspections, maintenance audits and inspections.
- Reviews of rules and procedures, training and certification, emergency response planning coordination and training system.
- System modification review and approval process.
- Safety data acquisition and analysis.
- Interdepartmental and interagency coordination.
- Configuration of management.
- Employee safety programs.
- Hazard materials programs.
- Drug and alcohol abuse programs.
- Contractor safety.
- Procurement.

A list of items to be audited will be developed by the Accountable Executive in advance of this audit, including checklists that address both quantitative and qualitative aspects of performance. The Accountable Executive will provide organizational units with time to produce documentation related to checklist items.

### **26.5 Audit Reporting**

The Chief Safety Officer will submit the audit checklist including findings, conclusions, and recommendations directly to the Accountable Executive.

### **26.6 Audit Objectives and Techniques**

Internal safety audits provide a mechanism for determining the effectiveness of the PTASP and an assessment of the implementation maturity level of Program elements.

#### **26.6.1 The Objectives of the Internal Safety Audit Program Include:**

- Verify safety programs have been developed/implemented in accordance with the PTASP requirements.
- Assess effectiveness of the PTASP.
- Identify PTASP deficiencies.
- Identify potential hazards in the operational system and weaknesses in the PTASP.
- Verify prior corrective actions are being tracked for closure.
- Recommend improvements to the PTASP.
- Provide management with assessment of status and adequacy of PTASP.
- Assure continuing evaluation of safety-related programs, issues, awareness and reporting.

#### **26.6.2 The Internal Safety Audit Program Encompasses All Aspects of Auditing Including:**

- Responsibilities
- Planning
- Scheduling
- Checklists
- Audit Performance
- Notifications
- Reporting
- Corrective Action Plans
- Closeout of Findings

#### **26.6.3 Major Issues and Activities Involved in Performing the Internal Safety Audit Include:**

- Examination of documentation
- Analysis of safety data and information
- Observation of equipment, facilities and in-process tasks
- Evaluation of system operation and employee workplace
- Interviews with management and staff

#### **26.6.4 During the Audit, the Safety Auditor Should Have Authority to:**

- Access records and facilities
- Issue reports
- Recommend corrective action plans

#### **26.6.5 Examples of Departmental Documentation Include:**

- Maintenance procedures
- Training manuals
- Proceedings of meetings
- Equipment specifications
- Rules and regulations of each department
- Management program plans

#### **26.6.6 Examples of District-Wide Documentation Include:**

- Public Transportation Agency Safety Plan
- Standard Operating Procedures
- Emergency Procedures
- Configuration Management Plan
- Hazardous Materials Management Plan
- Employee Handbook
- Safety Rules
- Drug and Alcohol Abuse Program
- Hazard Identification Procedures
- Accident and Incident Procedures
- "As Built" System Drawings
- Process Specifications

#### **26.6.7 Examples of Historical-Type Documentation Include:**

- Hazard Analysis
- Accident Investigations
- Audit Reports
- Surveys
- Test Results
- Logbooks
- Supervisor Reports
- Files
- Maintenance Inspection Reports and Repair Reports
- Safety Data Sheets

### **26.7 Audit Completeness**

While the audit process usually relies on the concept of spot-checking of sample areas being audited for compliance with internal procedures and requirements, it should not contain any surprises or unexpected events. All departments involved need to know when audits will be conducted and how they will examine departmental documents. While ongoing inspections may be conducted on an unannounced basis, actual audits should be done on a coordinated basis, with full management support. The following minimum audit components must be prescribed as part of the documented audit procedure.

#### **26.7.1 Audited Department Must Know When to Expect Audits**

Audits must be scheduled so that they are as unobtrusive as possible. Unannounced inspections or spot audits must be approved as part of the overall audit process with concurrence of general management.

#### **26.7.2 Checklists of Items to be Studied Must be Prepared in Advance**

When necessary, audited departments should be given time to produce necessary documentation.

This does not preclude spot check of individual records, such as maintenance records or personnel qualification records; however, the cooperative nature of the audit process must be maintained.

### **26.7.3 Documentation of a Formal Nature of All Aspects of the International Audit Process Must be Maintained**

### **26.7.4 Follow-Up or Corrective Action in a Summary of Recommended Corrective Actions, if any, Must be Included in the Audit**

Corrective action plans approved by management must then be formally tracked for compliance.

### **26.8 Follow-Up Action Plans**

Departments and other organizational units are sponsible for implementing their respective approved recommendations and corrective action plans within the established time frames. Future audits will determine compliance with this requirement.

### **26.9 Documentation and Checklists**

The Accountable Executive will maintain audit documentation. These records will be maintained in accordance with County Connection's Record Retention policy.

Where applicable, checklists will be used to assure completeness of the audit. Checklists for specific functions or locations may be used, or a generic checklist may be used.

### **26.10 Base Inspection Audits**

The Chief Operating Officer is responsible for the semi-annual Base Inspections. The Audit Team includes but is not limited to:

- Chief Operating Officer
- Director of Maintenance
- Director of Transportation
- Chief Safety Officer

### **26.11 Base Inspection Reporting**

All findings on an exception basis are documented and submitted to the Chief Operating Officer as "Base Inspections."

### **26.12 Revisions to the Public Transportation Agency Safety Plan (PTASP)**

The Chief Safety Officer will have the responsibility to incorporate any required changes into the PTASP and then re-distribute the reviewed PTASP.

## **27 INJURY & ILLNESS PREVENTION PROGRAM (IIPP) RESPONSIBILITIES**

### **27.1 General Manager**

The General Manager is responsible for overseeing that the IIPP is implemented. Duties include, but are not limited to:

- Ensuring all Executive staff, Directors and managers actively support the IIPP.
- Providing an appropriate environment and funds necessary to maintain an effective and compliant safety program.

### **27.2 Executive Staff**

Under direction of the General Manager, it is the responsibility of the Assistant General Manager, Chief Operating Officer, and Chief Finance Officer to support, encourage and champion an environment that encourages a safe and healthy work environment. Executive staff shall ensure

that all Directors and their respective departments actively support the IIPP. Individuals reporting dangerous conditions or shedding light on unhealthy practices and behavior should not be discouraged from doing so.

### **27.3 Directors**

Directors share in the responsibility in supporting, encouraging, and providing an environment that encourages a safe and healthy work environment. Directors are responsible for delegating to their managers and/or supervisors the responsibility of implementing the IIPP and all its activities.

### **27.4 Managers and/or Supervisors**

Managers and/or supervisors have the responsibility of providing a safe place to work including facilities, equipment, standards and procedures, adequate supervision and recognition for a job done properly. They are responsible for training all of their employees to perform their jobs properly and safely. They teach, demonstrate, observe, and enforce compliance with established safety standards.

### **27.5 IIPP Administrator (Director of Safety & Training)**

The Director of Safety & Training position has been designated as County Connection's IIPP Administrator and is the individual responsible for the implementation, maintenance, and ensuring this policy is kept up to date. The IIPP Administrator will be identified in all internal and external communications regarding County Connection's IIPP. If the IIPP Administrator position is vacant, Kristina Martinez, Manager of Human Resources will be designated as the interim IIPP Administrator. Kristina Martinez can be reached at (925) 680-2031 or kmartinez@cccta.org.

### **27.6 Employees**

Employees have the responsibility of performing their tasks properly and safely. They are to assure themselves that they know how to do the job properly and ask for additional training or assistance when they feel there is a gap in their ability, knowledge, or training. They should never undertake any task, job, or operation unless they are able to perform it safely.

## **28 COMPLIANCE**

### **A. Management Responsibility**

Management is responsible for ensuring that organizational safety and health policies are clearly communicated and understood by employees. Directors, managers and supervisors are expected to enforce the rules fairly and uniformly.

### **B. Employee Responsibility**

All employees are responsible for using safe work practices, for following directives, policies and procedures, and for assisting in maintaining a safe work environment.

### **C. Employee Recognition**

Employees, who make a significant contribution to the safety program, as determined by their supervisors, receive written acknowledgment that is filed in the employees' personnel files.

### **D. Employee Training**

Employees are trained on safety concerns as needed.



E. Employee Correction

Employees who fail to follow safe work practices and/or procedures, or who violate organizational rules or directives, are subject to disciplinary action, up to and including termination.

Supervisors correct safety violations in a manner considered appropriate by organizational management.

Notwithstanding the above, the organization reserves the right to correct in any fashion it deems appropriate, including the right to terminate immediately an employee for a safety violation.

## 29 COMMUNICATION

### 29.1 Two-Way Communication

Management recognizes that open, two-way communication between management and staff on health and safety issues is essential to an injury-free, productive workplace. County Connection fosters open and robust communication regarding safety between all levels of the agency. This starts with fully promulgating the safety policy to all employees. County Connection uses notices, posters, bulletins, electronic display to ensure all employees are aware of the agency's and their own safety commitments and requirements.

In addition, the Safety Department supports all other departments in ensuring safety messaging and awareness are communicated effectively within each department. Employees are required and encouraged to report hazards, take responsibility for safety in their tasks and work areas, educate themselves on safety in addition to formal training, and attend safety briefings, trainings, activities and events.

Finally, all levels of the agency are required, through formal and informal communications, to ensure safety information is disseminated throughout the agency. This Plan sets forth the requirements for both the formal and informal reporting that supports our Safety Management System (SMS).

A. The Organization's System of Communication

The following system of communication is designed to facilitate a continuous flow of safety and health information between management and staff in a form that is readily understandable.

1. An orientation program is given to all new employees and includes a review of the IIPP and a discussion of policy and procedures that the employee is expected to follow. All new employees are directed to County Connection's website to view the IIPP.
2. The transit system has safety meetings where safety is openly discussed by all present. All involved employees are expected to attend and are encouraged to participate in discussion.
3. Maintenance has implemented a monthly Safety Committee Meeting comprised of both representatives from management and employees.
4. At times when a general safety topic applies to all employees, everyone is expected to attend meetings where such topics are discussed.
5. From time to time, written safety notifications are posted throughout all transit system facilities and included in the transit system's employee newsletter.

6. Other methods of communicating pertinent health and safety information are used as they are identified.

Communication throughout the Agency consists of:

1. Safety Meetings
2. Topic-specific videos, posters, bulletins addressing risk-prioritized defensive driving and injury prevention topics
3. Safety Campaigns
4. Local Management Communications
5. Intranet Communications
6. Safety Posters and Bulletins
7. Electronic Display

### **30 SAFETY SUGGESTIONS AND HAZARD REPORTING**

- A. All employees are encouraged to inform their supervisors, or other management personnel of any matter that they perceive to be a workplace hazard, or a potential workplace hazard. They are also encouraged to report suggestions for safety improvement. This reporting can be done orally or preferably in writing. If done in writing, the notification may be given directly to the supervisor, the IIPP Administrator, or other management personnel.
- B. If employees wish to report anonymously a hazard, safety suggestion, or other safety problem, they can complete a form entitled *Report of Unsafe Hazardous Conditions*, not filling in their name.
- C. No employee shall be retaliated against for reporting hazards or potential hazards, or for making suggestions related to safety.
- D. Management reviews all suggestions and hazard reports.

### **31 HAZARD IDENTIFICATION AND EVALUATION**

Inspection of the workplace is our primary tool used to identify unsafe conditions and practices. While we encourage all employees to continuously identify and correct hazards and poor safety practices, certain situations require formal evaluation and documentation.

#### **31.1 Safety Inspections**

Internal facility inspections (to include safety issues) are conducted quarterly. Hazards found are corrected on the spot or recommendations are submitted for future corrections.

#### **31.2 Additional Inspections**

Inspections are also conducted in accordance with Cal-OSHA requirements:

- A. Whenever new substances, processes, procedures or equipment present a new safety or health hazard.
- B. Whenever management/supervision become aware of a new or previously unrecognized hazard, either independently or by receipt of information from an employee.
- C. Whenever it is appropriate to conduct an unannounced inspection.

### **32 INJURY/ILLNESS INVESTIGATION**

#### **32.1 Investigation**

All accidents resulting in injury or property damage, however slight, including *near misses*,

are investigated to determine the primary and contributing causes. This investigation is completed within seven working days of the initial report. This information is documented and analyzed to assist in obtaining corrective actions to prevent similar accidents from occurring in the future.

The responsibility to see that this investigation is performed rests with the IIPP Administrator when the event occurs either in the administrative offices or in operations. Management in maintenance fulfills this obligation for facility and vehicle maintenance staff.

### **32.2 Reporting**

All facts, findings, and recommendations are documented on an accident investigation report. Management reviews accident investigation reports with a view towards determining adequacy of corrective action.

### **33 CORRECTION OF HAZARDS**

When a hazard exists, it is corrected on a timely basis based on the severity of the hazard. If imminent danger exists to any employees, management and supervision remove these employees from the danger at once, and personnel who are provided with the necessary safeguards correct the hazard.

### **34 SAFETY PERFORMANCE MONITORING AND MEASUREMENT**

County Connection has established activities to:

- Monitor the Transit Agency system for compliance with, and sufficiency of, the agency's procedures for operations and maintenance.
- Monitor Transit Agency operations to identify hazards not identified through the Safety Risk Management process (per 49 CFR §673.25).
- Monitor Transit Agency operations to identify any safety risk mitigations that may be ineffective, inappropriate, or were not implemented as intended.
- Investigate safety events to identify causal factors; and monitor information reported through any internal safety reporting programs.

#### Management of Change

County Connection has established a process for identifying and assessing changes that may introduce new hazards or impact safety performance. If County Connection determines a change may impact its safety performance, then County Connection will evaluate the proposed change through its Safety Risk Management process.

#### Continuous Improvement

County Connection has established a process to assess its safety performance. If County Connection identifies any deficiencies as part of its safety performance assessment, then County Connection will develop and carry out, under the authority of the Chief Operating Officer, a plan to address the identified safety deficiencies.

### **34.1 Performance Monitoring and Measurement**

#### **A. Accident Investigation**

All employees and contractors are expected to comply with County Connection's accident and incident reporting procedures and use the forms prescribed. Roles, responsibilities, and accident reporting thresholds are outlined in the procedure, including accident notification, reporting, and investigation throughout the organization. The level of investigation required is dependent on the seriousness of the event.

Each accident/incident is investigated as specified in the County Connection Occurrence Report Form. The Occurrence Report Form complies with 49 CFR Part 672 and 673, State Safety Oversight Rule for bus incidents/accidents.

B. Accident/Incident Investigation and Reporting Criteria

County Connection must make reports available to DOT and the MPO regarding accidents/incidents. The Safety Manager conducts internal accident investigations on its behalf, unless otherwise notified.

All investigations conducted by County Connection will follow the Accident Investigation Plan.

DOT/MPO may participate in the investigation process when it is conducting the investigation on DOT's behalf. If DOT elects to address an investigation of accidents or incidents, County Connection may also conduct an independent investigation.

C. Internal Notification of Accidents/Incidents and Unacceptable Hazards

In the instance where an accident or incident occurs, the Supervisor or frontline employee will notify their Supervisor that an accident/incident has occurred. The Supervisor will provide the time of the occurrence, the location, and any other important details. The Emergency Notification Group includes the notification to the established appointed contacts at the location.

D. Notification of Accidents and Incidents to External Agencies

Recordable accidents tracked by County Connection and made available to DOT, MPO and FTA:

1. Fatality (occurring at the scene or within 30 days following the accident):
2. One or more persons requiring immediate medical treatment away from the scene of the accident
3. One or more vehicles incurring disabling damage and needing to be towed from the scene of the accident as result of the accident.

Job related employee fatalities shall be reported to OSHA within 8 hours of occurrence. In-patient hospitalization, amputation, or eye loss shall be reported within 24 hours.

Pursuant to the NTD Safety and Security Reporting Manual, **substantial damage** is defined as damage to any involved vehicles, facilities, equipment, rolling stock, or infrastructure that:

1. Disrupts the operations of the transit agency
2. Adversely affects the structural strength, performance, or operating characteristics of the vehicle, facility, equipment, rolling stock, or infrastructure, requires towing, rescue, on-site maintenance, or immediate removal prior to safe operation.

Substantial damage excludes damage limited to:

1. Cracked windows;
2. Dents, bends, or small puncture holes in the body

E. Accident/Incident Reporting and Documentation

Each bus investigation conducted on behalf of DOT must be documented in a final report that includes a description of investigation activities, findings, identified causal factors, and a corrective action plan, if applicable. All accident reports must follow the requirements established in the

Accident Investigation Plan. At its discretion, and as specified in its accident investigation plan, County Connection may separate its investigation report into two parts:

1. Description of investigation activities, investigation findings, and determination of the most probable cause and additional contributing causes; and
2. Recommendations to prevent recurrence, including a corrective action plan, which implements the recommendations.

County Connection prepares written accident and unacceptable hazardous condition reports on standard forms. Such written reports are maintained. Reports contain the most probable cause, other contributing causes, corrective action plans, and a schedule for implementing corrective actions.

The status investigation reports at a minimum shall include:

1. Minutes of any meeting held by a local safety ad hoc reportable event investigation committee or contractor;
2. Disclosure of any immediate corrective actions of planned or completed principal issues or items currently being evaluated; and
3. Overall progress and status of the investigation.

Written reports are filed for all occurrences that fall into the category of an accident, incident, or injury. The Safety Manager files a monthly statement of all accidents, incidents, unacceptable hazardous conditions, and tracks open corrective action items through completion.

In addition, County Connection maintains a file of the annual safety performance report in a format available for review by DOT at any time during an investigation. The report shall be prepared and a full briefing on the known circumstances of the event, status of County Connection's investigation and investigation activities.

Reports and records of accident investigations submitted to DOT by County Connection as well as related reports and records produced by both DOT and County Connection, will be treated as confidential information, and will not be released without concurrence by both DOT and County Connection.

#### F. Safety Data Acquisition

County Connection has the responsibility to monitor the safety performance of operations. The Chief Safety Officer is responsible for compiling and analyzing all safety data to determine if safety performance meets established safety goals. This data includes injuries to passengers, contractor personnel, public; potentially hazardous equipment failures; unacceptable hazardous conditions, and rules as well as procedure violations. A closed-loop reporting system for identifying and monitoring safety-related items has been established. To close out each incident, safety verification activities and results are reviewed and audited by the General Manager and reviewed by the Safety Manager. The Safety Manager is responsible for providing safety data to the General Manager for review. The Safety Manager monitors Safety Key Performance Indicators utilizing several tools and provides monthly progress updates to the General Manager.

Tracking of hazard related data is used to identify trends. These trends are further analyzed and/or investigated to determine causal factors. Tools available to the Safety Manager include Risk-Based Analysis, Monthly Performance reviews, EVR data, and data analysis and trends.

The Safety Manager is responsible for information regarding accidents, incidents, hazardous conditions, and operations, which are obtained from different reporting mechanisms. These include but are not limited to: Accident/Injury Reports and Investigations, Incident Reports, Daily Operations Summaries, Operator, and Supervisor Reports; Employee/Occupational Injury reports,

mining of maintenance data, analysis of vehicle records, and procurement contracts.

#### G. Internal Audits

The purpose of internal system safety audits is to perform an official evaluation of accomplishments, problems, and trends related to safety and to evaluate the effectiveness of the implementation of the Agency Safety Plan. The Safety Manager is responsible for the direction of the safety reviews and audits of its contractors to determine performance related to the Safety goals and objectives.

Organizational functions subject to the safety audit process include:

- Facility inspections
- Maintenance audits/inspections
- Review of rules, standard operating procedures, special bulletins, and orders
- Review of training/re-certification programs
- Emergency response planning, coordination, training
- Configuration Management
- Systems modifications (review and approval)
- Safety data analysis
- Employee safety programs
- Hazardous materials program
- Interdepartmental safety goals and objectives
- Occupational safety and health programs
- Contractor safety
- Procurement and specification engineering
- Drug and Alcohol Testing Program
- Any aspect or responsibility as outlined in this document

County Connection and contractors are subject to safety audits. The critical nature of certain operations requires rigorous development of reviews and audits. These include training, maintenance, and operations activities. Both periodic and no-notice inspections are undertaken to address all aspects of the activity including documentation, practices, and compliance with the Agency Safety Plan and other requirements. The Safety Manager reviews training, practices, and procedures to correct deficiencies identified during the performance of audits or other safety activities, including inspections and emergency drills.

#### H. Safety Audit Process

The Safety Manager is responsible for the management of the Internal Safety Audit Program. All County Connection employees and contractors are required to cooperate fully with Safety and Security personnel. Executive and senior managers ensure their areas participate fully in the safety audit process.

#### I. Integrity of the Process

To maintain the integrity of the review process, an external audit team is used to conduct safety audits. The Safety Manager does not perform audits/reviews of those functions and elements for which it is directly responsible to implement. No team member shall audit a function or activity for which they are responsible.

#### J. Auditing Cycle

The Internal Safety Audit Process is intended to be an ongoing, continuous safety review process.

Over a three-year period, all elements of the ASP must be audited at least once. The Internal Safety Audit Process is intended to be an ongoing, continuous safety review process. It is intended that at least 2 components of the ASP will be audited per year. The schedule is revised as necessary to accommodate schedules for auditors and the audited divisions.

The Audit Schedule presented in this section is as follows:

- Year 1
  - 1. Full SSPP (expected to be the last SSPP Audit)
  
- Year 2
  - 1. Safety Promotion
    - a. Training Program
    - b. Safety Communication
  
  - 2. General Requirements
  - 3. Safety Policy
    - a. Safety Management Policy
    - b. Employee Safety Reporting
    - c. Key Management & Responsibilities
  
- Year 3
  - 1. Risk Management
    - a. Risk Management
    - b. Safety Hazard Identification Safety Risk Assessment
    - c. Safety Mitigation
    - d. Safety Assurance:
    - e. Performance Monitoring and Measurement
    - f. Management of Change
    - g. Continuous Improvement

An annual audit schedule must be developed, reviewed, maintained and updated to ensure all elements are reviewed during the three (3) year audit cycle.

The Safety Manager notifies the division/organization a minimum of 30 days in advance of a scheduled safety audit.

#### K. Checklists and Performance of Safety Audits

The checklists include the elements on which the department will be audited. Checklists are prepared during the review of the Agency Safety Plan section, documents referenced in the Agency Safety Plan section, previous audits, and corrective actions.

Pre-audit and post-audit conferences are held by the audit team with the entity being audited. The safety audits are comprised of record reviews, interviews, field observations, and inspections and measurements to verify the accuracy of documentation and spot inspections of facilities and equipment to verify compliance with the Agency Safety Plan, procedures, codes, and regulations.

#### L. Rule Compliance

All County Connection employees and its contractors are responsible for the prevention of accidents, identification of hazards, and resolution of such hazards. Reports of all accidents, incidents, occurrences, deficiencies, near misses and defects will be maintained by the Manager of the appropriate department.

County Connection is assigned the responsibility for the safe operation of vehicles. Responsibilities include:

- Preparation and implementation of safe operating policies, plans, rules and procedures.
- Development of safety policies, plans, rules, and procedures for safe operation and maintenance.
- Personnel are annually re-trained in the proper performance of all applicable safety-related rules and procedures that cover their specific job function.
- Ensure the number of hours worked during a seven-day period does not exceed DOT limits.
- Ensure the number of consecutive days worked does not exceed DOT limits.
- Employees are provided copies of safety and emergency rules, procedures, and policies that affect them.
- Monitoring adherence to safety-related operating and maintenance policies, plans, rules and procedures through periodic in-service evaluations using the "Observation Report Form" by County Connection Supervisors or a Manager. All deficiencies are reported, in written form, for review, re-instruction, or re-training. Supervisor Driver Evaluations, and rule conformance frequency shall follow the requirements outlined in Employee Qualifications & Rule Book.
- When necessary, performance coaching or re-instruction training for Supervisors is performed by County Connection. Supervisors are expected to comply with all rules and enforcement thereof, as they apply to the management of bus service and the management of personnel. Additionally, Supervisor skills are assessed annually from participation in the driver Recertification Program.
- Personnel, whose safety record requires follow-up, additional training or discipline, including discharge, are identified through maintenance of records.
- County Connection will be required to develop a preventive maintenance schedule, for each system hardware element, which is designed to maintain system safety. Reported deficiencies and defects in equipment and facilities are corrected and monitored to assure satisfactory resolution. Only equipment known to be free of safety-related defects are placed into service.

## **35 TRAINING**

### **35.1 Initial On-The-Job Training**

When an employee first starts to work, a manager or supervisor trains the employee in all aspects of safety. This training is completed to ensure the new employee knows how to recognize the hazards of the work environment and the required safety procedures to mitigate those hazards.

The manager/supervisor conducts this training and documents it by using the *Employee Safety Training and Meeting Report* or similar form. The manager or supervisor and the employee sign the form when the training is completed. The form then becomes a permanent part of the employee's personnel file.

### **35.2 Specific Organizational-Wide Training**

#### **A. Disaster Preparedness**

This training includes the organization's disaster preparation structure and how the employee fits into the structure, i.e., what the employee is to do under specific circumstances, such as fire, earthquake, medical emergency, and bomb threat.

#### **B. First Aid, AED, CPR, and Bloodborne Pathogen Training** Designated employees receive first aid, AED, CPR, and bloodborne pathogen training.



### **35.3 Retraining**

Reasons for retraining include change of job assignment, change of operations or materials, observation of poor work habits, or update of training methods.

### **35.4 Specialized Training**

#### **A. Management/IIPP Administrator:**

1. Determine safety-training needs.
2. Implement new training programs.
3. Evaluate the effectiveness of these programs.

#### **B. In addition, training is provided whenever:**

1. New substances, processes, procedures or equipment pose a new hazard and there is a lack of skill or knowledge to deal with the situation.
2. Management, supervision, the IIPP Administrator become aware of a previously unrecognized hazard and there is a lack of skill or knowledge to deal with the hazard.

#### **C. Accident Prevention:**

1. Training and Education – Providing knowledge and skills necessary to identify hazards.
2. Safety Regulations and Compliance – Adhering to specific standards for safe working environments.
3. Maintenance & Inspection – Ensuring the equipment is regularly inspected and properly maintained.

#### **D. Right Turn and Left Turn:**

1. Signal early – Use the signal in advance for an intended turn. Check blind spots (due to their size).
2. Positioning (Right Turn) – Move to the proper lane and position the commercial vehicle closer to the right curb or edge of the road.
3. Positioning (Left Turn) – Position the commercial vehicle in the appropriate lane to make a left turn. Be aware of lane markings and dedicated left-turn lanes.
4. Plan for the turn – Assess the size of the intersection and plan the turn accordingly.
5. Be aware of pedestrians – Check crosswalks and prepare to yield the right of way.

#### **E. Bus Stop:**

1. Signal early – Indicate your intention to stop by activating your signal well in advance.
2. Check mirrors and blind spots – Before initiating the stop, check all your mirrors to know the traffic conditions.
3. Move to the Right Lane – If possible, move the bus to the right lane, aligning it to the curb or designated service stop area. Ensure that the bus is close enough to the curb if possible.

4. Monitor Passenger Activity – Make sure passengers board and alight safely. Provide assistance to passengers with mobility challenges as needed.

#### Mirror Usage:

1. Adjustment before driving – Adjust mirrors to provide the broadest possible view.
2. Regular mirror checks – Periodically check mirrors to make sure they remain adjusted.
3. Side mirrors and convex – Monitor traffic and check mirrors before changing lanes and making turns. Use the convex mirror to monitor your blind spots.
4. Stay informed – Continuously scan mirrors to stay knowledgeable of the traffic around you.

### 36 SAFETY PERFORMANCE TARGETS

#### Implementation of a Measurement & Evaluation System

The transit system reviews selected results and activities to ascertain whether its efforts are being successful and asks: why are we doing better? and/or why are we doing worse? The transit system uses a frequency rate to compare itself from one time period to another. The frequency rate is calculated by using the following equation:

$$\text{Fleet frequency rate} = \frac{\# \text{ of accidents} \times 100,000}{\# \text{ of miles driven}}$$

The result is a rate that equals *the number of accidents that the system has sustained for every one hundred thousand miles driven.*

#### Safety Performance Targets

Accidents – Total number of reportable accidents and rate per total vehicle revenue miles over a year. Analyzing the factors that relate to accidents is a significant step in developing actions to prevent them.

Injuries – Total number of reportable injuries and rate per total vehicle revenue miles over a year. Analyzing the factors that relate to injuries is a significant step in developing actions to prevent them.

Falls – Total number of all reportable falls and rate per total vehicle revenue miles over a year. Tracking and then reducing fall events will support efforts to reduce falls.

Fatalities – Total number of reportable fatalities and rate per total vehicle revenue miles over a year. As an agency we must understand the factors involved in each fatality to prevent further occurrences.

System Reliability – Distance between major mechanical failures. This is a measurement of how well a fleet of transit vehicles are maintained and operated.

### 36.1 Accidents

Total number of reportable accidents and rate per total vehicle revenue miles:

	<u># of Accidents</u>	<u>Miles Driven</u>	<u>Frequency Rate</u>
2022:	35	3,080,151	1.13
2023:	24	2,980,935	.80

### 36.2 Injuries

Total number of reportable passenger injuries (not including falls) and rate per total vehicle revenue miles:

	<u># of Injuries</u>	<u>Miles Driven</u>	<u>Frequency Rate</u>
2022:	4	3,080,151	.12
2023:	9	2,980,935	.30

### 36.3 Falls

Total number of reportable falls and rate per total vehicle revenue miles:

	<u># of Falls</u>	<u>Miles Driven</u>	<u>Frequency Rate</u>
2022:	34	3,080,151	1.10
2023:	38	2,980,935	1.27

### 36.4 Fatalities

Total number of reportable fatalities and rate per total vehicle revenue miles:

	<u># of Fatalities</u>	<u>Miles Driven</u>	<u>Frequency Rate</u>
2022:	0	3,080,151	0
2023:	1	2,980,935	.03

### 36.5 System Reliability

Distance between major mechanical failures:

	<u># of Major Road Calls</u>	<u>Miles Driven</u>	<u>Frequency Rate</u>
2022:	114	3,080,151	3.70
2023:	86	2,980,935	2.88

## 37 SAFETY PERFORMANCE TARGET COORDINATION

County Connection will transmit safety performance targets to Caltrans' division of Rail and Mass Transit and to the Metropolitan Transportation Commission (MTC). Safety performance targets will be transmitted to Caltrans and the MTC thirty (30) days after initial Board approval of the Safety Plan. The targets will be transmitted annually to MTC and Caltrans by September 30 to assist in their planning process for the future and identifying investment priorities for upcoming transit projects.

#### Targets Transmitted to the State: Caltrans

Upon approval of Plan and annually by September 30.

#### Targets Transmitted to the Metropolitan Planning Organization: Metropolitan Transportation Commission

Upon approval of Plan and annually by September 30.

This Agency Safety Plan addresses all applicable requirements and standards as set forth in FTA's Public Transportation Safety Program and the National Public Transportation Safety Plan.

APPROVED BY:

\_\_\_\_\_  
Chief Operating Officer, *Accountable Executive*

\_\_\_\_\_  
Date

\_\_\_\_\_  
Board Chairman/Designee

\_\_\_\_\_  
Date

RECOMMENDED BY:

\_\_\_\_\_  
General Manager, *Safety Management System Executive*

\_\_\_\_\_  
Date

\_\_\_\_\_  
Chief Safety Officer

\_\_\_\_\_  
Date

**CENTRAL CONTRA COSTA TRANSIT AUTHORITY**  
*Cal-OSHA Serious Injury/Illness Reporting Requirements*

***What to report to Cal-OSHA upon learning of a serious occupational injury or illness.***

Within eight (8) hours of learning of an occupational injury or illness that involves death or serious injury (see the transit system's employee Injury & Illness Prevention Program (IIPP) regarding conducting accident investigations), the IIPP Administrator is required to provide the following information to Cal-OSHA at 925-602-6517\*:

1. Time and date of accident.
2. Employer's name, address and telephone number.
3. Name and job title, or badge number of person reporting the accident.
4. Address of site of accident or event.
5. Name of person to contact at site of accident.
6. Name and address of injured employee(s).
7. Nature of injury.
8. Location where injured employee(s) was (were) moved to.
9. List and identity of other law enforcement agencies present at the site of accident.
10. Description of accident and whether the accident scene instrumentality has been altered.

\*This telephone number is for the Cal-OSHA Enforcement Unit Region 2 office located at 1465 Enea Circle, Building E, Suite 900, Concord, CA 94520.

# CENTRAL CONTRA COSTA TRANSIT AUTHORITY EMPLOYEE REPORT FORM

**Use of this Form**

Please use this form whenever you have something to report regarding a safety matter. Your report may be based on your observation of an unsafe practice, an unsafe condition, a problem associated with managerial policies and/or procedures or some other matter. *It is the policy of Central Contra Costa Transit Authority that employees will not be retaliated against for submitting a safety report.* Our goal is to eliminate accidents and your help is what it is all about. Please feel free to use additional sheets of paper to describe fully your identified problem and suggestion.

**Identified Problem and Suggestion**

**Name of Employee Submitting Suggestion (optional\*):** \_\_\_\_\_

**Telephone Number (optional\*):** \_\_\_\_\_

\*If you provide your name and telephone number, you will be kept informed as to the status of your suggestion. Without this information, it will not be possible to keep you updated.

**Complete Description of Identified Problem** – If the problem is based upon a specific circumstance, please include the date and time that you saw it:

**Description of Suggestion(s)** - What changes do you recommend to correct the problem?

\_\_\_\_\_  
Signature of Employee (optional)

\_\_\_\_\_  
Date

\* \* \*

**Investigative Response**

**Employee Submitting Report: Please Do Not Write in this Section.**

**Name of Person Investigating Problem and Suggestion:** \_\_\_\_\_

**Results of Investigation** - What was found?

**Recommended Steps to Correct the Identified Problem** - The recommendations may be the same as the employee who submitted this form.

\_\_\_\_\_  
Signature of Investigator

\_\_\_\_\_  
Date

# CENTRAL CONTRA COSTA TRANSIT AUTHORITY

## *Employee Safety Training and Meeting Report*

**Use of this Form**

1. All safety training programs and meetings (including tailgates) conducted for transit system employees, are documented on this form.
2. The completed form is distributed and filed as follows:
  - a. Training Programs
    - 1) One copy is filed with the master training file for each course. The master file includes this form, the training course curriculum, all training handouts, and anything else that pertains to the training program.
    - 2) If appropriate, one copy is given to the Human Resources Department where the following information is retrieved and inserted into each attendee's personnel file on the transit system's *Record of Training Form*:
 

a) Name of employee	d) Training subject
b) Employee's department	e) Whether a certificate was issued
c) Date of training	
  - b. Safety or Tailgate Meetings  
 This form is filed with the master meeting file for each safety or tailgate meeting. The master file includes this form, the safety or tailgate meeting agenda, all safety or tailgate meeting handouts and anything else that pertains to the safety or tailgate meeting.

Was Program a Training Program? (Yes / No)	Was Program a Safety or Tailgate Meeting? (Yes / No)
Training/Safety or Tailgate Meeting Subject(s):	
Certificate Issued (circle answer):            Yes    No	
Training/Meeting Date:	Training Instructor/Meeting Leader Name(s):
Description of Training Provided or Safety or Tailgate Meeting Topic:	
Course or Meeting Handouts (attach to this form):	

### Attendance Roster

<u>Employee Name (print)</u>	<u>Employee Name (signature)</u>	<u>Employee's Department</u>

**CENTRAL CONTRA COSTA TRANSIT AUTHORITY**  
**NEW EMPLOYEE SAFETY ORIENTATION CHECKLIST**

Use of this Form

1. All new employees receive general safety orientation training. All such safety training is documented on this form.
2. The completed checklist is filed in each new employee's personnel file.
3. Check off that each topic has been covered.
4. Both the person who conducts the orientation and the employee sign and date that the orientation training has been completed.

	<u>Orientation Topics</u>	<u>Check When Completed</u>
1.	Review of the transit system's <i>Injury &amp; Illness Prevention Program</i> – The instructor conducts a detailed review of this document with the employee. The employee receives a copy of the IIPP and signs for it using the receipt designed for the purpose.	_____
2.	Review of those aspects of the transit system's <i>Employee Emergency Plan</i> that pertains to the employee.	_____
3.	Review of the employees' <b>right-to-know</b> about hazardous substances in their work environment and provision of information about the transit system's <i>Hazardous Waste Training Program</i> , available in their departments.	_____
4.	Review of <b>specific accident prevention tips</b> of the most common types* of employee accidents to be avoided.	_____
4.a.	*Back injury prevention	_____
4.b.	*Slip, trip and fall prevention	_____
4.c.	*Cut prevention	_____
4.d.	*Electrical shock prevention	_____
4.e.	*Driving accident prevention	_____
4.f.	*Ergonomics-related injury/illness prevention	_____
5.	Summary of information covered.	_____

\_\_\_\_\_  
Date of Orientation

\_\_\_\_\_  
Instructor Name (Printed)

\_\_\_\_\_  
Employee Name (Printed)

\_\_\_\_\_  
Instructor Signature

\_\_\_\_\_  
Employee Signature



CENTRAL CONTRA COSTA TRANSIT AUTHORITY  
Safety Inspection Form/Action Plan

Location: \_\_\_\_\_

Page 1 of \_\_\_\_\_

Facility Inspected: \_\_\_\_\_

Name of Inspector(s): \_\_\_\_\_

Date of Inspection: \_\_\_\_\_

Date of Report: \_\_\_\_\_

# of items corrected from previous inspections: \_\_\_\_\_ out of \_\_\_\_\_

# of items uncorrected from previous inspections: \_\_\_\_\_

# of items uncorrected in this inspection: \_\_\_\_\_

# of items corrected on the spot in this inspection: \_\_\_\_\_

# of total items remaining uncorrected in this report: \_\_\_\_\_

Number (%) of total items uncorrected by priority:

Priority I (Urgent): \_\_\_\_\_ ( \_\_\_\_\_ %)

Priority II (Necessary): \_\_\_\_\_ ( \_\_\_\_\_ %)

Priority III (Desirable): \_\_\_\_\_ ( \_\_\_\_\_ %)

Report Recipients: \_\_\_\_\_  
\_\_\_\_\_  
\_\_\_\_\_

For information regarding this inspection, please contact: \_\_\_\_\_

CENTRAL CONTRA COSTA TRANSIT AUTHORITY  
Safety Inspection Form/Action Plan

Location: \_\_\_\_\_

Page 2 of \_\_\_\_\_

TC	P	\$	Item No. Yr-Mo-Day	Observations	Recommendations	Current Status

Key

TC: Check this column when the action is corrected

P: Priority (I-Urgent, II-Necessary, III-Desirable)

\$: Estimated amount to correct (L = \$0 to \$250, M = \$251 to \$1000, H = \$1001 +, T = Time Only)

**Central Contra Costa Transit Authority**

**SUPERVISOR'S INVESTIGATION REPORT (Occupational Injury or Illness)**

Time is of the essence. Please be as complete and concise as possible. If you need additional space, please use additional sheets of paper and note the paragraph number and letter. The information you provide should help prevent a similar occupational injury or illness in the future.

1. WHO:

1.a. Name of Injured Employee: \_\_\_\_\_

1.b. Department/Division: \_\_\_\_\_

1.c. Date of Hire: \_\_\_\_\_

1.d. Normal Occupation of Employee (Job Classification):

1.e. Name(s) of Witness(es):

2. WHEN:

2.a. Date of Incident: \_\_\_\_/\_\_\_\_/\_\_\_\_

2.b. Time of Incident: \_\_\_\_\_AM \_\_\_\_\_PM

2.c. Date Reported to You: \_\_\_\_/\_\_\_\_/\_\_\_\_

2.d. Time Reported: \_\_\_\_\_AM \_\_\_\_\_PM

2.e. Did Employee Leave Work Due to Incident? \_\_\_\_Yes \_\_\_\_No

2.f. Did Employee Return to Work? \_\_\_\_Yes \_\_\_\_No

If Yes, When (Date and Time): \_\_\_\_/\_\_\_\_/\_\_\_\_ \_\_\_\_\_AM \_\_\_\_\_PM

3. WHERE: (Describe Where the Incident Happened):

4. WHAT:

4.a. Describe the Injury or Illness, such as cut, strain, fracture, skin rash:

4.b. What Part of the Body was Affected, such as back, left wrist, right eye, lungs:

4.c. What was employee doing when injured? (Be specific by identifying tools, equipment or materials being used.) Use additional paper, if necessary.

5. HOW AND WHY: Did any of the following factors have anything to do with how and why the incident occurred? If you answer YES or PARTLY, please provide further information. Do whatever you need to do to determine whether these factors were involved.

Factors	Yes	Partly	No
a. Lack of knowledge or skill			
b. Error			
c. Lack of (or incorrect) policies, procedures, rules			
d. Lack of (or insufficient) safety training			
e. Too many demands and/or pressures			
f. Lack of sufficient number of people to do the work			
g. Hazards			
h. Insufficient, improper, or unrepaired equipment and/or tools			
i. Incorrect design of facilities, equipment, materials			
j. Inattention			
k. In a hurry			
l. Anything else?			

6. PREVENTABILITY:  
 In your opinion, was this incident preventable? (Circle your answer):    Yes    No Why?

7. 7.a. What is the LOSS SEVERITY POTENTIAL? (Circle your answer): Major  
     Serious                Minor  
 7.b. What is the PROBABLE RECURRENCE RATE? (Circle your answer): Frequent  
     Occasional            Rare

8. CORRECTIVE ACTION: What actions have or will be taken to prevent a recurrence?

	<u>Expected Completion Date</u>	<u>Actual Completion Date</u>
a.		
b.		
c.		

9. 9.a. Investigating Supervisor's Name (Print): \_\_\_\_\_  
 9.b. Title: \_\_\_\_\_  
 9.c. Investigating Supervisor's Signature: \_\_\_\_\_  
 9.d. Date: \_\_\_\_\_

10. File a copy in the employee's personnel file and any other investigation files.

## GLOSSARY

<u>TERM</u>	<u>DEFINITION</u>
ADA	American with Disabilities Act. Passed in 1990, this federal legislation calls on public transit systems to make their services fully accessible and to underwrite a parallel complementary network of paratransit service.
Accident	An unforeseen, unintended event or occurrence resulting in injury, death, contact, or property damage.
BART	Bay Area Rapid Transit District provides heavy rail public transit service in San Francisco, San Mateo, Alameda, and Contra Costa counties.
DOT	Department of Transportation. At the federal level, a cabinet agency with responsibility for highways, mass transit, aviation and ports; headed by the Secretary of Transportation.
FTA	Federal Transit Administration. Agency of the United States Department of Transportation that provides federal transit financing, policy, and programs.
Fixed Route	Public transit service that operates on a regular basis over a predefined route at predefined times and published in a public timetable (e.g., bus and rail).
Hazard	Any real or potential condition that can cause injury or death, or damage to or loss of equipment or control.
Hazard Analysis	An analysis performed to identify hazardous conditions for the purpose of their elimination or control.
Incident	An unforeseen event or occurrence that does not result in injury, death, contact, or property damage.
Paratransit	Transportation service required by the ADA for individuals with disabilities who are unable to use fixed-route service.
Public Transit	Provision of general transportation service by a public agency to the public on a regular and continuing basis.
Revenue Service	The operation of a transit vehicle in scheduled service for the use of passengers.
Risk Management	An element of the system safety management function that evaluates the safety effects of potential hazards considering acceptance, control, or elimination of such hazards with respect to expenditure or resources. (The feasibility of hazard elimination must be considered in light of financial, legal, and human considerations.)
Safety Critical	Safety Critical is a designation placed on a system, subsystem, element, component, device, or function denoting that satisfactory operation of such is mandatory to assurance of patrons, personnel, equipment, or facility safety. Such a designation dictates incorporation of special safety design features.
SDS	Safety Data Sheets (SDS) replace Material Safety Data Sheets (MSDS).



Complete as it applies to your property, or note N/A

## OCCURRENCE REPORT FORM

License No. 2702735

TYPE OF OCCURRENCE (Circle One)		Collison	Passenger	Incident Observation
Member	Date of Occurrence	Time	Report Number	Occurrence Type
Full Name of Employee		Employee Badge Number		___ Full Time ___ Part Time
Social Security No.		Date of Birth		Hire Date
Occurance On (Street,/Roadway/Avenue, etc.)		At or Between		City
Transit Vehicle Identification Number	Was Transit Vehicle Damaged? ___ Yes ___ No	Line	Route No.	Run No.
General Direction (eastbound, etc.)	Weather Condition (clear, fog, etc.)		Condition of Roadway	
Bus On Time?	Minutes Late	Number of Passengers	Number of Courtesy Cards Obtained	

Description of Accident: For additional information use extra report form.

Brief Summary: \_\_\_\_\_

Describe in Detail: \_\_\_\_\_

\_\_\_\_\_

\_\_\_\_\_

\_\_\_\_\_

\_\_\_\_\_

Date of Report	Employee Signature Indicate Classification: ___ Operator ___ Student ___ Other	Time Stamp	Initials
----------------	---	------------	----------

**TRAFFIC DIAGRAM (IMPORTANT)** Draw complete diagram of where and how occurrence happened using symbols shown below. Show street names and indicate direction of travel of vehicle involved.

Show points of contact on vehicles with a check (✓). Indicate path of vehicle(s) **BEFORE** collison with a solid line ( \_\_\_\_\_ ) and **AFTER** the collison with a broken line ( \_ \_ \_ \_ \_ ).

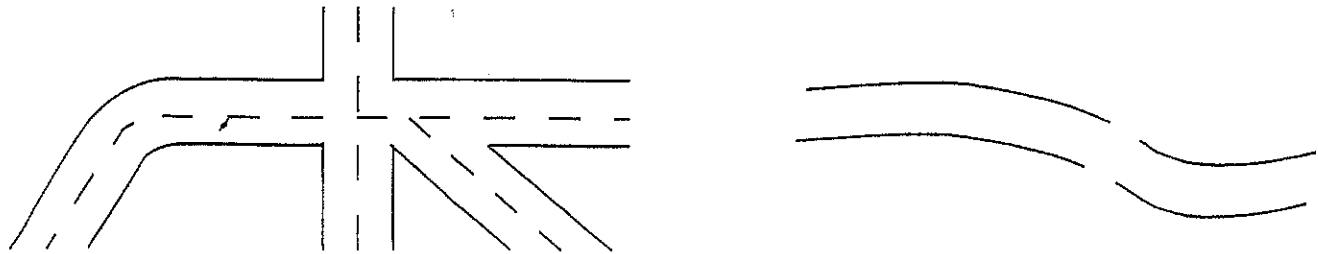
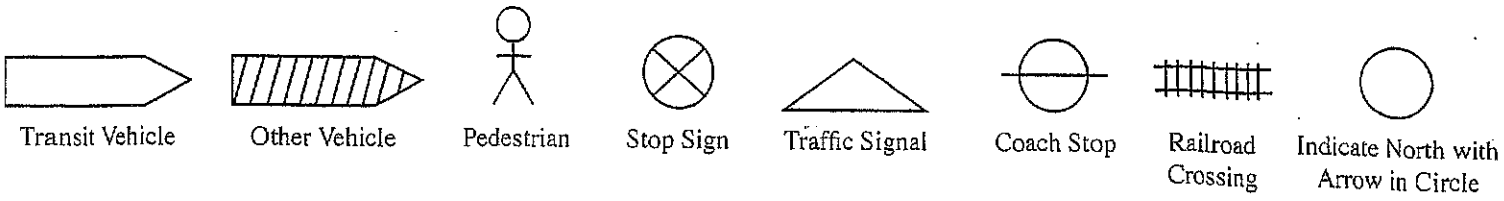

Police at Scene of Occurrence? Yes      No		Report No.	City		Indicate Each Square with Y - Yes or N - No												
Road Supervisor? Yes      No		Road Supervisor's Name	Badge Number	Photographs? Yes      No	Ambulance Requested	Claimed Injuries	Apparent Injuries	Passenger	Pedestrian	Other Vehicle	Approximate Age						
<b>PERSONS INJURED OR PROPERTY INVOLVED</b>																	
	Name	Address & Telephone	City	Zip													
1																	
2																	
3																	
4																	
5																	
6																	
7																	
8																	
9																	
10																	

<b>PASSENGER OCCURRENCE</b>				<b>PEDESTRIAN OCCURRENCE</b>			
Was Person	If a Fall Give Location		If Crime		Was Person In		
Boarding	Front Steps		Fare Evader	Crosswalk			
Exiting	Front Platform		Struck Pass.	Loading Zone			
Onboard	Aisle Seat		Struck Op.	Rear Doors			
At Front Door	Rear Platform		Damaged Bus	Jay Walker			
At Rear Door	Rear Steps		Theft	Direction			
Struck by Door	Wheelchair Ramp		Other	Other			
Did person contact transit vehicle in fall?    Yes    No				If pedestrian not in crosswalk, how far from crosswalk _____ feet.			
Distance of transit vehicle entrance/exit from curb _____ feet.							
Or fall was _____ feet from transit vehicle.							

<b>OTHER VEHICLE INFORMATION</b>			
Registered Owner	Address	State/City/Zip	Telephone
Driver	Address	State/City/Zip	Telephone
Vehicle License No. & State	Driver's License No. & State	Type & Make of Vehicle	
No. of Persons in Vehicle	Damage to Vehicle or Property	Insurance Carrier & Policy No.	

**MUST BE FILLED OUT FOR ALL OCCURRENCES (PASSENGERS - TRAFFIC - PEDESTRIAN)**

**MOTION OF TRANSIT VEHICLE: Check proper item**

Standing	Running		Speed bus was traveling:  _____ MPH	Was there any unusual motion of Transit Vehicle?    Yes    No
Starting	Straight			
Stopping	Curve			

<b>Motion of Vehicles Involved:</b>	<b>Transit Vehicle</b>	<b>Other Vehicle</b>
Estimated Speed When Danger First Noticed	M.P.H.	M.P.H.
Estimated Speed At Time Of Occurrence	M.P.H.	M.P.H.
Distance from Point of Occurrence When Danger First Noticed	Feet	Feet
Distance Traveled After Occurrence	Feet	Feet
If At Night, Were Street Lights On?    Yes    No		
If At Controlled Intersection, What Color Were Traffic Lights?	E/B    W/B    N/B    S/B	
Describe Damage to Transit Vehicle		
Condition of Equipment - Circle Defective Items -    Steps    Floors    Doors    Seats    Brakes    Other		
Describe Defects -		
Were Defects Reported Prior to Occurrence?    Yes    No    To Whom?		
Noted on Operator's Report of Defects?    Yes    No		



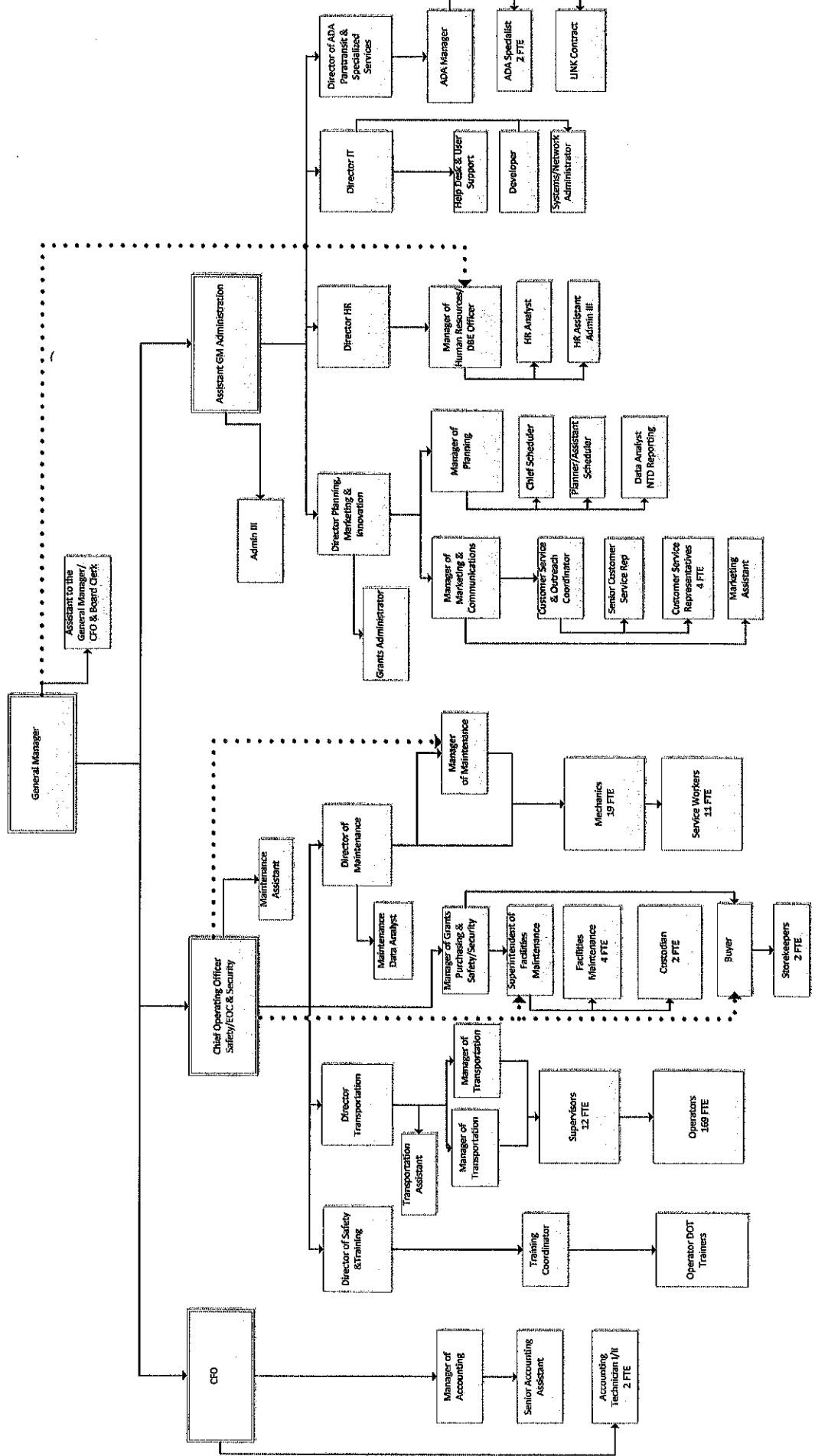

**RESOLUTION NO. 2024-015**

**BOARD OF DIRECTORS, CENTRAL CONTRA COSTA TRANSIT AUTHORITY  
STATE OF CALIFORNIA**

\* \* \*

**APPROVING REVISED COUNTY CONNECTION  
PUBLIC TRANSPORTATION AGENCY SAFETY PLAN**

**WHEREAS**, the County of Contra Costa and the Cities of Clayton, Concord, Lafayette, Martinez, Orinda, Pleasant Hill, San Ramon, and Walnut Creek, and the Towns of Danville and Moraga (hereinafter “Member Jurisdictions”), have formed the Central Contra Costa Transit Authority ("CCCTA"), a joint exercise of powers agency created under California Government Code Sections 6500, *et seq.*, to provide coordinated and integrated public transportation services within the area of such Member Jurisdictions;

**WHEREAS**, on July 19, 2018, the Federal Transit Administration ("FTA") published the Public Transportation Agency Safety Plan ("PTASP") Final Rule that requires certain transit operators of public transportation systems that receive federal funds under FTA's Urbanized Area Formula Grants (49 U.S.C. § 5307) to develop a PTASP that includes the processes and procedures to implement a Safety Management System ("SMS");

**WHEREAS**, as an operator of a public transportation system that receives Federal financial assistance under Title 49 of the United States Code Chapter 53, CCCTA is required to develop and adopt a fully compliant PTASP;

**WHEREAS**, on November 19, 2020, CCCTA's Board of Directors approved the County Connection PTASP;

**WHEREAS**, on February 17, 2022, the FTA issued a Dear Colleague Letter regarding changes to PTASP requirements as a result of the Bipartisan Infrastructure Law ("BIL"), also known as the Infrastructure Investment and Jobs Act ("IIJA");

**WHEREAS**, transit agencies that receive Section 5307 funding are required to establish a Safety Committee compliant with 49 U.S.C. § 5329(d)(5);

**WHEREAS**, CCCTA created its Safety Committee, consisting of an equal number of frontline employee and management representatives, which convened its first meeting on March 29, 2022 and continues to meet quarterly and oversees any revisions to the PTASP;

**WHEREAS**, the Safety Committee approved an update to the PTASP that includes the BIL/IIJA requirements and an Accident Reduction Program; and

**WHEREAS**, staff recommends and the Operations and Scheduling Committee concurs that the Board approve, and authorize the General Manager to sign, the revised PTASP.

**NOW THEREFORE BE IT RESOLVED** that the Central Contra Costa Transit Authority Board of Directors hereby approves the revised County Connection Public Transportation Agency Safety Plan and authorizes the General Manager, or designee, to sign the revised County Connection Public Transportation Agency Safety Plan and take any actions necessary in furtherance of this Resolution.

Regularly passed and adopted this 21st day of March, 2024, by the following vote:

AYES:

NOES:

ABSTAIN:

ABSENT:

---

Don Tatzin, Chair, Board of Directors

ATTEST:

---

Lathina Hill, Clerk to the Board