

To: Operations and Scheduling Committee

Date: 8/29/2024

From: Kyle Boehm, Grants Administrator

Reviewed by: AMS

SUBJECT: Real Time Bus Stop Sign Program Update

Background:

In 2016, County Connection entered into a five-year agreement with Waysine, LLC for the lease of 20 solar-powered bus stop signs that provide real-time information to passengers at designated bus stops. Since the agreement has expired, County Connection staff conducted an inventory of the installed signs and researched options to continue and/or replace the existing signs.

Project Update:

Based on the existing condition of the installed signs and the opportunity presented for upgrading the technology, staff recommends replacing the existing signs with 28 new signs incorporating the newest technology from Urban Solar. The signs are 13-inch e-paper displays that are battery powered, display real-time data updated every 10 seconds, are enclosed in vandal-resistant enclosures, and include ADA-compliant text-to-speech capability. The content and layout of the new signs are customizable and will be designed to fit the information and branding needs of County Connection. In discussions with the vendor, solar power was considered for the new signs, however, given the increased cost, the variability in solar feasibility at each individual stop, and advances in battery technology leading to longer lifespans, the battery powered displays were ultimately recommended as the best fit for this implementation.

One sign is proposed for the stop with the greatest number of boardings in each of the jurisdictions within the County Connection service area (if that stop averages at least 10 boardings per day), with the remaining 18 signs proposed for the other busiest stops throughout the service area that are nonconsecutive, enabling greater distribution along certain routes and streets. Bus stops at the BART stations and transit centers have been excluded from this proposal pending completion of the Metropolitan Transportation Commission's (MTC) Regional Mapping & Wayfinding Project.

Financial Implications:

County Connection will procure the real-time signs through the California Association for Coordinated Transportation (CalACT) contract. The proposed cost includes a three-year hardware and battery warranty, a three year license for the Content Management System, data, Urban Solar's operational fee, shipping and associated charges, and installation. The cost is included in the Fiscal Year 2025 Capital Budget.

Item	Quantity	Unit Cost	Total
13-inch e-paper display	28	\$7,000	\$196,000
Text-to-speech button	28	\$900	\$25,500
Project set-up fee (data integration)	1	\$6,950	\$6,950
Installation	1	\$20,950	\$20,950
		Total	\$250,000

Recommendation:

Staff recommends the purchase of the 28 real-time bus stop signs and associated services as described above.

Action Requested:

Staff requests the O&S Committee recommend Board approval for the General Manager to execute the Real Time Sign Agreement with Urban Solar.

Attachments:

1. Urban Solar Product Information
2. List of Proposed Installation Sites



Product Information

Pole Mounted Lighting &
Display Signage

For more information or to learn
about our demo program reach out
to our team!

Info@urbansolarcorp.com
778-430-5516 (CAN)
503-356-5516 (USA)



Why Urban Solar?

North American leader in solar power systems specifically designed for public transit:

- **Mission:** Power Better Bus Stops
- **Goal:** Increase security and visibility of riders at every bus stop
- Have deployed pole and shelter mounted solar systems at **20,000+ bus stops**
- **Goal:** Ensure riders are comfortable and informed at every bus stop
- Ability to integrate and power multiple stop amenities **completely off of grid power** (lighting, real time signage, remote monitoring etc.).



Why Urban Solar?

In recent years agencies have demanded more from their solar powered bus stops...

- Digital display technology and GTFS-RT feeds have allowed for power friendly solutions that pair well with our solar lighting technology
- Urban Solar has powered displays from multiple signage providers, giving us unique insight into power consumption figures, deployment processes and ongoing support available throughout the market
- Urban Solar has partnered with Axentia Technologies to offer real-time signage options (see digital signage section)



Why **200+ Transit Agencies** across North America trust Urban Solar to power their bus stops:



Reliable Operation

Each system is designed using NASA solar data to ensure sufficient solar panel and battery capacity for optimal year round performance regardless of location.



Free Site Inspections

Free site inspections ensure that each one of your systems will receive adequate sun exposure for reliable operation even in the darkest winter months.



Free Installation Support

We offer free installation support for every installation, big or small.



USA-Made and UL Listed

All Urban Solar systems are proudly made in the USA and meet Buy America requirements. Many systems also carry a system-level UL listing.



Industry leading Warranty

All solar systems come with an industry-leading system warranty including a five-year pro-rated battery warranty.



Tough enough for Transit

Robust metal housings and vandal-resistant hardware protect your investment even in the toughest neighborhoods.

Urban Solar Deployments...

Long Beach Transit - **Long Beach, CA**

King County Metro – **Seattle, WA**

Orange County Transit Authority – **Orange County, CA**

Durham Region Transit - **Toronto, ON**

LA Metro – **Los Angeles, CA**

Intercity Transit – **Olympia, WA**

Topeka Metro – **Topeka, KS**

Omnitrans – **San Bernardino, CA**

Capital Metropolitan Transit Authority – **Austin, TX**

Corpus Christi RTA - **Corpus Christi, TX**

City of Tempe – **Tempe, AZ**

Red Deer Transit – **Red Deer, AB**

WeGo Public Transit – **Nashville, TN**

MARTA – **Atlanta, GA**

Spokane Transit Authority – **Spokane WA**

BC Transit – **Victoria, BC**



Pole Mounted Lighting

Easily deployed security lighting, and power for digital signage at your next generation of bus stop.

- **Reduces rider pass-bys:** The top complaint reported by transit agencies
- **Installs in minutes** at any bus stop with a standard transit pole
- **Tough enough for transit:** all-aluminum construction, UL-listed, made in the USA, 10-year warranty.
- **Lighting Profile:** Fully customizable, optional push-button activation
- **Real-time information display** integration.
- **20W** or **40W** Solar array available

Pole Mounted Lighting Options: PV Stop+

Specifications:

- **Solar array size:** 20W/40W
- **Battery:** 20Ah, 12.8V
- **Battery chemistry:** LiFePO4 (Sealed lead acid optional for cold climates)
- **Battery autonomy:** 5+ nights
- **Luminaires:** up to 3, 5W each
- **Controller:** Urban Solar ECM™ with real time clock
- **I/O:** power with low voltage disconnect, battery state of health data via RS232/RS485
- **Operating range:** -40 to 140 °F (-40 to 60 °C)
- **Pole dimensions:** round or square, 1.75" to 3" diameter

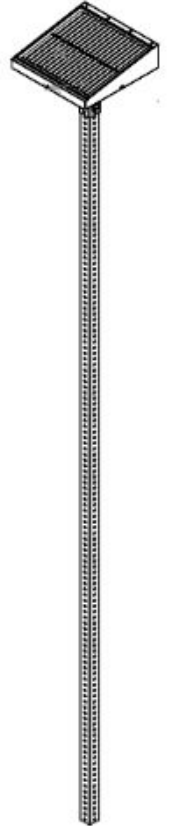
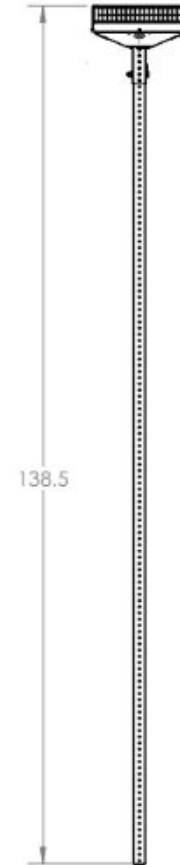
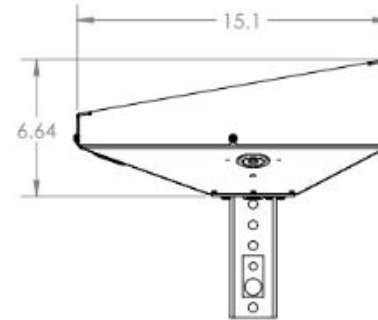
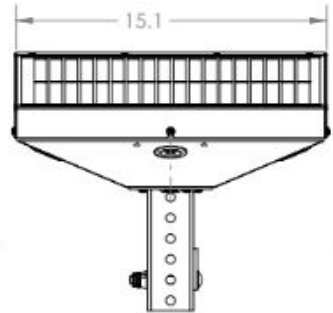
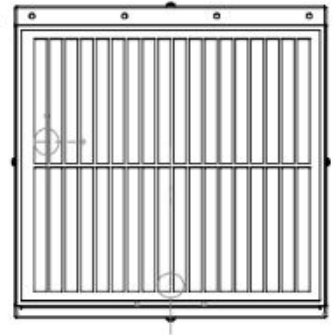

Pole Mounted Lighting Options: PV Stop+

Budgetary Pricing Leveraging CalACT (\$USD)

PV Stop+:	\$1,571
PV Stop Max (42W):	\$1,958
Push Button Operation:	+\$100
3 Luminaire configuration:	+\$200
Pair with Digital Signage:	Call for Price



Digital Displays

Real Time Passenger Information at Every Stop

Benefits:

- Improved rider comfort and trust
- Decreased perceived wait times
- Improved communication with your riders, push messaging and alerts

Urban Solar has partnered with **Axentia Technologies** to bring their digital displays to North America



Why Axentia?

Advanced Technology

Real-time information systems and implementations in public transit information, rescue communications and emergency alert systems

Market Leading Efficiency

Company background in military communications requires high standards of reliability and extremely low power consumption. The Axentia e-paper solution is ~20x more energy efficient than the nearest e-paper competitor

Experience in Large Scale Deployments

Deployments 25,000+ displays including multiple deployments of 1000+ units at once.



References

More than 25,000 displays

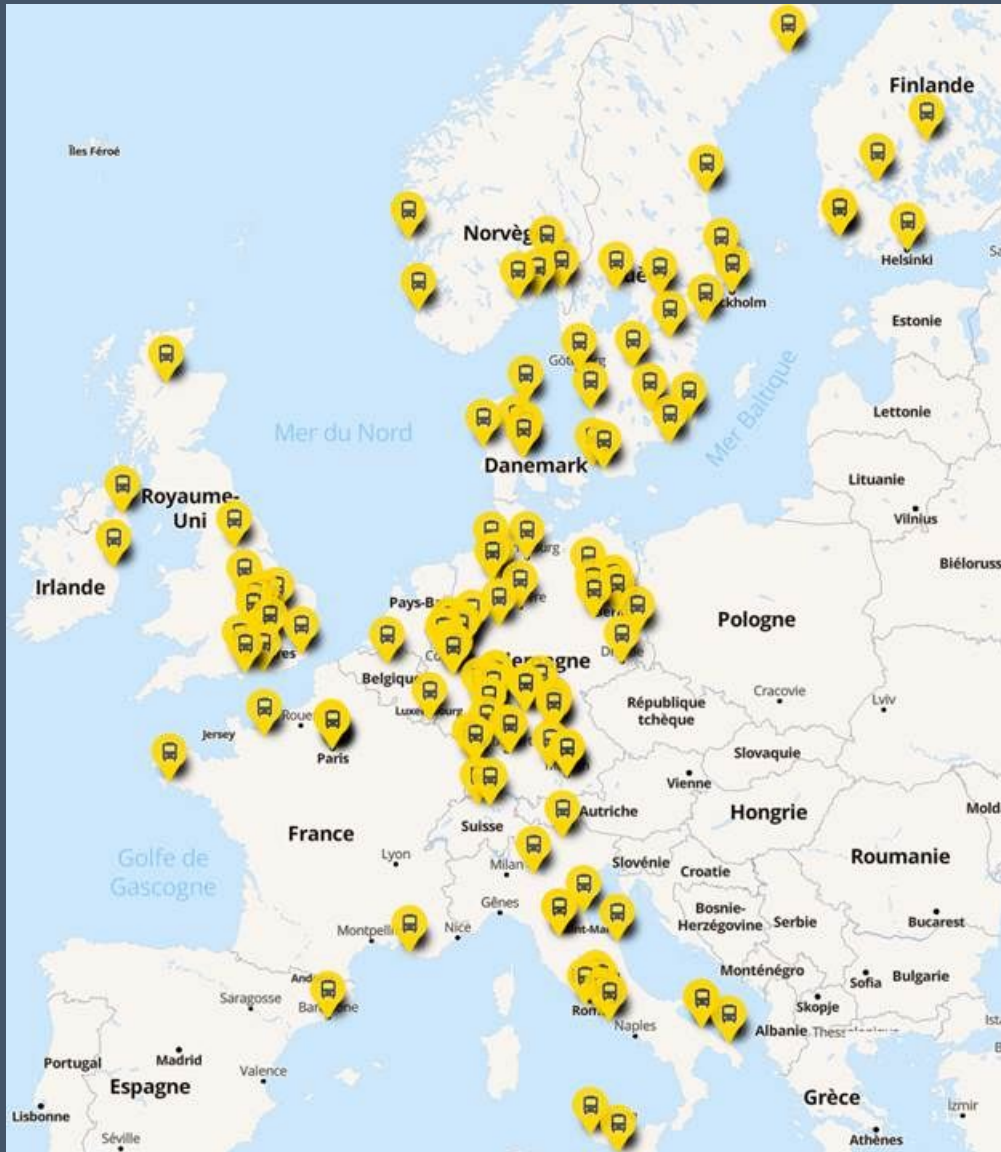

Finland

- Helsinki
- Turku
- Tampere

Sweden

- Stockholm
- Gothenburg
- Skåne
- Blekinge
- Karlstad
- Jönköping
- Uppsala
- Sörmland
- Örebro

Norway

- Oslo
- Vestfold/Telemark
- Stavanger
- Östfold

Denmark

- Copenhagen
- North Jutland
- Aarhus

Germany

- Munich
- Stuttgart
- Köln
- Berlin
- Augsburg
- Dresden
- Bochum
- Bremen
- Bremerhaven
- Hannover
- Hamburg
- Darmstadt
- Mannheim
- BadBelzig/Potsdam
- Würzburg

Belgium

- Brussels
- DeLijn

France

- Strasbourg
- Paris
- Marseilles

Italy

- Brescia
- Tuscany

UK & Ireland

- Leeds
- Portsmouth
- Hampshire
- Dublin

Canada

- Vancouver

Digital Display Features

Battery Powered!!!

Deploy digital signage where it will have the largest impact on your riders! Not based on where you can access power / solar

3 – 5 years between battery changes and without any need of external power.

True real-time

Latency updates of both data and display within maximum 10 seconds using full roaming on 4G/5G LTE.

Uses any available data feeds such as GTFS, GTFS-RT, VDV, SIRI and many others.

Tough enough for Transit

Vibration-dampened all-aluminium housing, replaceable shatter resistant screen protector, made in the USA

Customizable Content & Layouts

Tailor the information / branding to the needs of your riders and agency. Push messaging to ensure your riders are always informed

Easy to Maintain

No need for continuous maintenance except from potential battery replacements every **3 - 5 years**

Visibility into system health via online portal

Practical benefits

- **Easy Installation:** Easily integrated in existing infrastructure such as poles, shelters etc (take less than 30 minutes to install)
- **ADA Compliant:** Text-to-speech available
- **Solar Integration:** At solar viable locations, tie our solar systems to your displays to extend the battery life to **7 – 10 years**
- **Clear Readability:** Backlight/front light always on when dark, no need for motion sensors with Anti-reflective treated front-glass
- No external cables or antennas needed

Digital Display Options

E-Paper



13" E-paper Display



13" 4 button E-paper Display



13" Top of pole E-paper Display



32" E-paper Display

LCD



2 – 5 row LCD Displays

Digital Display Options

ZURICH



32" E-paper Display

ESSLINGEN



13" 4 button E-paper Display

PORTSMOUTH



13" Top of pole E-paper Display

Additional Resources - Recent Projects



Wilsonville, OR



South Clackamas, OR



University of Wisconsin

Vandal Resistant Enclosure

Vandalism is a challenge all transit agencies are currently facing - To protect your asset we have designed a protective enclosure

- Anti-reflective anti-fog polycarbonate screen protector
- Vibration dampening to protect the electronics if the display takes an impact
- Recessed security hardware to prevent unauthorized access
- Easy and cost effective maintenance
- Optional Graffiti shield

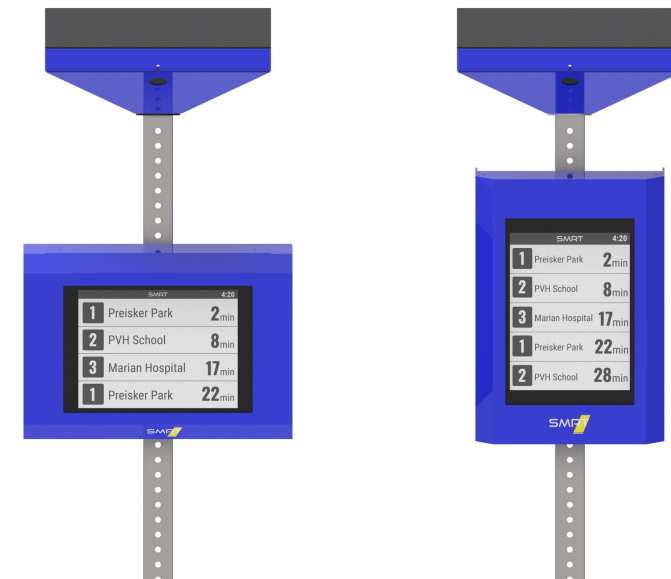

Digital Display Pricing

Budgetary Pricing for Leveraging CalACT Contract (\$USD)

13" E-Paper Display: (1 - 9) \$7,500 (10+) \$7,000

3-Row LCD Display: (1 - 9) \$7,000 (10+) \$6,500

External Text to Speech Button w/ Braille (optional): \$900/unit

Project Setup Cost : \$6,950*

- Includes GTFS-RT integration, collaborative layout design, product training, CMS training, and Installation training

(Optional) Integration with Solar System: Call for Price

Pricing includes:

- 3 year hardware & battery warranty
- 3 years of CMS access, Data and Operational Fees
- Shipping and associated charges

* First unit must be purchased along with the one-time set up fee

pricing for other signage options available upon request



Location of Proposed Real-Time Signage		
Stop ID	Stop Name	City
447	Clayton Rd/Clayton Library	Clayton
543	Clayton Rd and Kirker Pass Rd	Concord
545	Clayton Rd and Terry Lynn Ln	Concord
551	Clayton Rd and Thornwood Dr	Concord
553	Clayton Rd and Dekinger Ct	Concord
563	Clayton Rd and Fry Way	Concord
567	Clayton Rd and Adelaide St	Concord
571	Concord Blvd and Grant St	Concord
604	Contra Costa Blvd and Golf Club Rd	Pleasant Hill
618	Detroit Ave and Walters Way	Concord
656	Laguna St and Detroit Ave	Concord
696	Mohr Ln and Monument Blvd	Concord
710	Monument Blvd and Meadow Ln	Concord
712	Monument Blvd and Lacey Ln	Concord
717	Monument Blvd and Reganti Dr	Concord
790	Monument Blvd and Oak Grove Rd	Concord
858	Sun Valley Blvd and Santa Monica Dr	Concord
859	Willow Pass Rd and Diamond Blvd	Concord
1264	Alhambra Ave/Contra Costa Regional Medical Center	Martinez
1322	St. Mary's College	Moraga
1450	Contra Costa Blvd/Viking Dr	Pleasant Hill
1465	Crescent Plz and Crescent Dr	Pleasant Hill
1681	Sunset Dr/Bishop Dr	San Ramon
1778	Mitchell Dr and Park and Ride Lot	Walnut Creek
1880	S Broadway/ Mt Diablo Blvd	Walnut Creek
1988	Oak Grove Rd and Treat Blvd	Concord
2198	Treat Blvd and Oak Grove Plaza Drive	Concord
2224	Railroad Ave/Church St	Danville