

CENTRAL CONTRA COSTA TRANSIT AUTHORITY

NOTICE AND INVITATION FOR BIDS

INSTRUCTIONS TO BIDDERS AND GENERAL CONDITIONS

FORM OF CONTRACT

TECHNICAL SPECIFICATIONS

FOR

**INSTALLATION OF ABOVE GROUND DIESEL
FUEL STORAGE TANKS**

CENTRAL CONTRA COSTA TRANSIT AUTHORITY

PROJECT NUMBER

2026-MA-01

INVITATION FOR BID DATE: FEBRUARY 25, 2026

PRE-BID MEETING: MARCH 9, 2026

**REQUEST FOR APPROVED EQUALS, MODIFICATIONS OR CLARIFICATIONS:
MARCH 16, 2026**

**RESPONSE TO REQUESTS FOR APPROVED EQUALS, MODIFICATIONS OR
CLARIFICATIONS: MARCH 23, 2026**

BID OPENING DATE: MARCH 26, 2026

**WILLIAM CHURCHILL
GENERAL MANAGER**

TABLE OF CONTENTS

NOTICE INVITING SEALED BIDS..... 5

BID FORM 7

ITEMS TO BE INCLUDED IN BID..... 10

BIDDER’S SECURITY..... 11

NON-COLLUSION DECLARATION..... 12

BIDDER’S EQUAL EMPLOYMENT OPPORTUNITY (EEO) CERTIFICATION..... 13

LIST OF SUBCONTRACTORS 14

LIST OF PRIME CONTRACTOR AND SUBCONTRACTORS/SUPPLIERS 15

SBE GOOD FAITH EFFORT FORM..... 16

FAIR EMPLOYMENT PRACTICES CERTIFICATE..... 17

WORKERS’ COMPENSATION CERTIFICATION 18

BIDDER’S STATEMENT OF QUALIFICATIONS AND BUSINESS REFERENCES..... 19

CONTRACT 23

PUBLIC WORKS PROVISIONS 30

 1. Prohibition Against Contracting with Debarred Subcontractors 30

 2. Use of Subcontractors..... 30

 3. Prompt Payment to Subcontractors 30

 4. Non-Collusion Declaration..... 30

 5. Assignment of Claims 30

 6. Third-Party Claims 30

 7. Claims Procedures 30

 8. Utility Relocation 32

 9. Excavation 32

 10. Trench Safety 32

 11. Payment Bond 32

 12. Contractor’s License Requirements and Public Works Registration 32

 13. Labor Code Requirements..... 33

 14. Payment of Workers’ Compensation..... 36

 15. Examination and Audit of Records (Gov. Code section 8546.7) 36

 16. Notice of Taxable Possessory Interest (Rev. and Taxation Code section 107.6)..... 36

 17. Antitrust Claim Assignment..... 36

 18. Coordination With Federal and California Prevailing Wage Laws..... 36

 19. Permits, Licenses, Training..... 36

 20. Wage Kickbacks and Worker Registration Fees Prohibited..... 37

INSTRUCTIONS TO BIDDERS AND GENERAL CONDITIONS..... 38

 1. Definition of Terms 38

 2. Canvass of Bid..... 38

 3. Scope of Work..... 38

 4. Pre-Bid Meeting and Job Walk 38

 5. Requests for Approved Equals, Modifications or Clarifications..... 39

 6. Brand Names 40

 7. Specifications 40

 8. Bidding Procedures 40

 9. Bid Form and Signature..... 41

 10. Bid 41

 11. Bidder’s Security 41

 12. Conditioned Bid 42

TABLE OF CONTENTS (Continued)

13. Alternative Bid	42
14. Submission of Bid	42
15. Withdrawal of Bid	42
16. Firm Bid	42
17. Taxes	42
18. Inspection By Bidder and Waiver	43
19. Rejection of Bid.....	43
20. Basis of Award, Execution and Delivery	43
21. Protest Procedures	44
22. Statement of Experience and Qualifications	45
23. Non-Collusion Declaration.....	45
24. Penalty for Collusion.....	45
25. Prohibited Interest	45
26. Interest of County Connection Personnel.....	46
27. Time for Execution of Contract and Filing Performance and Payment Bonds	46
28. Execution of Contract, Manner of.....	46
29. Payment and Performance Bonds.....	46
30. Additional Sureties	46
31. Changes of Contract By Contractor	47
32. Changes of Contract By County Connection	47
33. Documents Incorporated as Part of Contract.....	47
34. Statement of Financial Assistance	47
35. Delivery	47
36. Extensions of Time.....	47
37. Failure to Complete Contract	47
38. Termination	48
39. Payments	48
40. Waiver	49
41. Liquidated Damages.....	49
42. Defective or Damaged Work.....	49
43. Assignment.....	49
44. Compliance with Laws and Regulations	49
45. Law of California	49
46. Warranty of Title	49
47. Warranty of Fitness	49
48. Warranty of Merchantability	49
49. Warranty of Product	50
50. Contractor’s Indemnity.....	50
51. Risk of Loss.....	50
52. Records	51
53. Subcontracts	51
54. Audit.....	51
55. Disadvantaged Business Enterprises	51
56. Equal Employment Opportunity.....	53
57. Safety and Health Standards.....	53
58. Civil Rights Requirements	53

TABLE OF CONTENTS (Continued)

59. Quality of Construction	54
60. Right to Inspect	54
61. Discrepancies.....	55
62. Independent Contractor	55
63. Interpretation	55
64. Correspondence	55
65. Time of Essence	55
66. Insurance Provisions.....	55
67. Acceptance of Contract	55
68. Measurement and Payment.....	55
69. IFB Schedule	55
70. Inspection of Work.....	56
71. Patents, Infringement Of.....	56
72. Acceptance of Work.....	56
73. Project Schedule	57
PERFORMANCE BOND.....	58
PAYMENT BOND.....	60
APPROVED EQUAL FORM.....	62
TECHNICAL SPECIFICATIONS	64

ADDENDA

AS-BUILT DRAWINGS
SITE MAP

CENTRAL CONTRA COSTA TRANSIT AUTHORITY

NOTICE INVITING SEALED BIDS

The Chief Financial Officer will receive sealed bids in their office, located at 2477 Arnold Industrial Way, Concord, California 94520, at any time prior to the hour of **2:00 p.m., on Thursday, March 26, 2026**, for:

INSTALLATION OF ABOVE GROUND DIESEL FUEL STORAGE TANKS

COUNTY CONNECTION PROJECT 2026-MA-01

Bids must be submitted on Central Contra Costa Transit Authority's (County Connection) "Bid Form," enclosed in a *sealed* envelope clearly marked "INSTALLATION OF ABOVE GROUND DIESEL FUEL STORAGE TANKS." Bidders shall submit one (1) original and one (1) copy of the bid.

A pre-bid meeting and job walk will be conducted on March 9, 2026, at 10:00 a.m. at the County Connection Maintenance Building, located at 2477 Arnold Industrial Way, Concord, CA 94520. Although attendance at the pre-bid meeting is not mandatory, it is strongly encouraged to assure bidders are familiar with the scope of work and to ask any questions relative to this Invitation for Bids.

County Connection hereby notifies all bidders that it is the policy of County Connection to ensure nondiscrimination on the basis of race, color, sex or national origin in the award and administration of contracts that it awards. County Connection has committed to a three-year, overall DBE goal of 3.5% for the participation of small, disadvantaged business enterprisers; however, at this time, County Connection is not counting DBE participation toward its overall goal. Please see Paragraph 55 of the Instructions to Bidders and General Conditions for more information. Bidders are urged to obtain Small Business Enterprise (SBE) participation for this contract, although there is no specific SBE contract goal. Bidders are encouraged to attend the Pre-Bid Meeting to better understand the applicable SBE requirements. For assistance, contact Kristina Martinez, DBE Officer, at (925) 680-2031

All bids must be accompanied by cash, a cashier's check or a bidder's bond in the amount of ten percent (10%) of the bid price, as described in the Contract Documents, which shall be applied to damages sustained by County Connection if the successful Bidder fails or refuses to enter into the contract awarded to it.

Bids will be examined and reported to the County Connection Board of Directors within sixty (60) calendar days after the bid opening. County Connection reserves the right to reject any and all bids or to waive any irregularity or informalities in any bid or in the bidding procedure, or to postpone the bid opening for good cause. No bidder may withdraw its bid for a period of sixty (60) days after the date of opening of bids. Each Bidder will be notified of award of contract, if award is made.

This is a Public Works Contract. In accordance with section 1720 et seq. of the Labor Code, the general prevailing wage rates as established by the Director of the California Department of Industrial Relations will apply to the Contract. The prevailing wage rates established by the State Director of Industrial Relations can be viewed at County Connection's offices, are available on the State of California's website at <http://www.dir.ca.gov/> or can be obtained by mail addressed to: Prevailing Wage Unit, Division of Labor Statistics and Research, Department of Industrial Relations, P.O. Box 603, San Francisco, CA 94101.

No contractor or subcontractor may be listed on a bid proposal for a public works project unless registered with Department of Industrial Relations (DIR) pursuant to Labor Code section 1725.5 at the

time of bid. (See Labor Code section 1771.1(a).) Additionally, no contractor or subcontractor may be awarded a contract for public works unless registered with DIR pursuant to California Labor Code section 1725.5. This project is subject to monitoring and enforcement by the DIR pursuant to Labor Code Section 1771.4.

Pursuant to California Civil Code Section 3247, the successful bidder shall furnish a payment bond if civil work exceeds twenty-five thousand dollars (\$25,000).

Bidders bidding as the prime contractor shall possess a valid State of California Contractor's License, Type A-General Engineering and Type HAZ-Hazardous Substance Removal Certification.

Contractors and any approved subcontractors shall hold such current and valid Contractor's Licenses as required by California law at the time of award. All subcontractors shall be properly licensed by the State of California to perform specialized trades.

Contract documents may be inspected and obtained at County Connection's office at 2477 Arnold Industrial Way, Concord, California 94520. Requests for contract documents or general questions may be emailed to Josh Wiens, Maintenance Data Analyst at wiens@cccta.org.

Copies of the Invitation for Bid may be downloaded at County Connection's website at countyconnection.com.

Date: February 17, 2026

WILLIAM CHURCHILL
GENERAL MANAGER

EXHIBIT B

BID FORM

CENTRAL CONTRA COSTA TRANSIT AUTHORITY

Concord, California

Board of Directors
Central Contra Costa Transit Authority
2477 Arnold Industrial Way
Concord, CA 94520

The undersigned, upon acceptance, agrees to install two (2) 25,000 gallon above ground diesel fuel storage tanks at the fuel island at Central Contra Costa County Transit Authority's facility located at 2477 Arnold Industrial Way, Concord, CA 94520. In accordance with the terms and conditions set forth in Central Contra Costa Transit Authority's "Notice Inviting Sealed Bids, Instructions to Bidders and General Conditions, Scope of Work, Form of Contract, and Technical Specifications, including As-Built drawings" for "Installation of Above Ground Diesel Fuel Storage Tanks " dated _____, _____, at the following price:

ITEM I

**ABOVE GROUND INSTALLATION
OF TWO (2) 25,000 GALLON DIESEL
FUEL STORAGE TANKS:**

\$ _____

EQUIPMENT REQUIRED FOR INSTALLATION,
INCLUDING: Veeder-Root Red Jacket turbines,
Tank monitors, interstitial monitors, line monitors,
TLS-450PLUS ATG console, and Bennett Dispensers

\$ _____

TOTAL PRICE:

\$ _____

Contractor's License Number _____

Contractor's License Class(es) _____

Contractor DIR Registration Number _____

BID FORM

Name under which business is conducted _____

Business Address _____

Telephone _____

IF SOLE OWNER, Sign here:

I sign as sole owner of the business named above: _____

IF PARTNERSHIP, Sign here:

The undersigned certify that we are partners in the business named above and that we sign this contract bid with full authority to do so: (one or more partners sign)

IF CORPORATION, Execute here:

The undersigned two individuals certify that they sign this contract bid with full and proper authorization to do so:

Corporation Name _____

By _____ Title _____

By _____ Title _____

Incorporated under the laws of the State of: _____

If the bidder is a corporation, two corporate officers must sign on behalf of the corporation as follows: (1) one signature must be that of the chairman of the board, president or vice-president; and (2) the second signature must be that of the secretary, assistant secretary, chief financial officer or assistant treasurer. Alternatively, this bid may be executed by a single officer or a person other than an officer provided that evidence satisfactory to County Connection is provided demonstrating that such individual is authorized to bind a corporation (e.g., a copy of a certified resolution from the corporation's board or a copy of the corporation's by-laws).

IF JOINT VENTURE, Execute here:

The undersigned certify that they sign this contract bid with full and proper authorization to do so:

Joint Venture Name Composed of _____

By _____ Title _____

By _____ Title _____

Bid packages shall be placed in a sealed envelope marked "Above Ground Diesel Tanks Installation" and delivered to the Chief Financial Officer, County Connection, 2477 Arnold Industrial Way, Concord, CA 94520 prior to 2:00 p.m., on March 26, 2026.

ITEMS TO BE INCLUDED IN BID

- A. Bidder's Security
- B. Non-Collusion Declaration
- C. Bidder's EEO Certification
- D. List of Subcontractors
- E. List of Prime Contractor and Subcontractors/Suppliers
- F. SBE Good Faith Effort Form
- G. Fair Employment Practices Certificate
- H. Workers' Compensation Certification
- I. Bidder's Statement of Qualifications and Business References

BIDDER'S SECURITY

KNOW ALL PERSONS BY THESE PRESENTS:

That _____, as Principal, and

_____, as a California-admitted Surety, are held and firmly bound unto the Central Contra Costa Transit Authority, hereinafter called the "County Connection", in the sum of _____ dollars (\$_____), being at least ten percent (10%) of the total amount of the bid of the Principal above named, for the payment of which sum in lawful money of the United States of America to County Connection we bind ourselves, our heirs, executors, administrators, successors and assigns, jointly and severally, firmly by these presents.

The condition of the above obligation is such that, whereas the Principal has submitted said bid to County Connection for which bids were requested to be received at Concord, California, on _____, 20____ for the Installation of Above Ground Diesel Fuel Storage Tanks project, as specified therein.

NOW THEREFORE, if the Principal is awarded a contract by County Connection and, within the time and in the manner required by the Specifications, enters into a contract with County Connection and furnishes the requisite bonds or other contract documents, then this obligation shall become null and void; otherwise to remain in full force and effect.

In the event suit is brought upon this bond by County Connection and judgment is recovered, the Surety shall pay all costs incurred by County Connection in such suit, including reasonable attorney's fees to be fixed by the court.

Signed and sealed this _____ day of _____, 20_____.

Principal _____

By: _____

By: _____

(Note: Signature of person executing for Surety must be notarized and evidence of power of attorney attached)

Surety: _____

By: _____

Attorney-In-Fact

NON-COLLUSION DECLARATION

**TO BE EXECUTED BY BIDDER AND SUBMITTED WITH BID
(In accordance with California Public Contract Code Section 7106)**

Project Title: Installation of Above Ground Diesel Fuel Storage Tanks

The undersigned declares:

I am the _____ of _____, the party making the foregoing bid.

The bid is not made in the interest of, or on behalf of, any undisclosed person, partnership, company, association, organization, or corporation. The bid is genuine and not collusive or sham. The bidder has not directly or indirectly induced or solicited any other bidder to put in a false or sham bid. The bidder has not directly or indirectly colluded, conspired, connived, or agreed with any bidder or anyone else to put in a sham bid, or to refrain from bidding. The bidder has not in any manner, directly or indirectly, sought by agreement, communication, or conference with anyone to fix the bid price of the bidder or any other bidder, or to fix any overhead, profit, or cost element of the bid price, or of that of any other bidder. All statements contained in the bid are true. The bidder has not, directly or indirectly, submitted his or her bid price or any breakdown thereof, or the contents thereof, or divulged information or data relative thereto, to any corporation, partnership, company association, organization, bid depository, or to any member or agent thereof to effectuate a collusive or sham bid, and has not paid, and will not pay, any person or entity for such purpose.

Any person executing this declaration on behalf of a bidder that is a corporation, partnership, joint venture, limited liability company, limited liability partnership, or any other entity, hereby represents that he or she has full power to execute, and does execute, this declaration on behalf of the bidder.

“I declare under penalty of perjury under the laws of the State of California that the foregoing is true and correct and that this declaration is executed on _____ [date], at _____ [city], _____ [state].”

Signature of Bidder

Title

Date

BIDDER'S EQUAL EMPLOYMENT OPPORTUNITY (EEO) CERTIFICATION

Bidder's Name

Bidder's Address

Bidder's Total Number of Employees

GENERAL

Bidder certifies and agrees that all persons employed by it, its affiliates, subsidiaries, or holding companies are and will be treated equally by the firm(s) without regard to or because of race, color, religious creed, national origin, ancestry, sex, age, physical or mental disability, medical condition, marital status, veteran's status, sexual orientation, gender identity, or genetic information.

BIDDER'S CERTIFICATION

1. The Bidder has a written policy statement prohibiting any discrimination in all phases of employment.

Yes _____

No _____

2. This policy statement is available for inspection to any of Bidder's employees or to any applicants for employment.

Yes _____

No _____

3. The Bidder periodically conducts a self-analysis or utilization analysis of its workforce. This analysis is reviewed and updated at least annually.

Yes _____

No _____

4. The Bidder has a system for determining if its employment practices are discriminatory against protected groups.

Yes _____

No _____

5. Where problem areas are identified in employment practices, the Bidder has a system for taking reasonable corrective action to include establishment of affirmative action goals and timetables.

Yes _____

No _____

Printed Name and Title of Authorized Representative

Signature

Date

LIST OF SUBCONTRACTORS

In compliance with the provisions of Sections 4100-4114, inclusive, of the Public Contract Code of the State of California, each Bidder shall set forth the name, business address, contractor's license number of each subcontractor whom the Bidder proposes to have perform work or labor or render service in or about the construction of the work in an amount in excess of one-half of one percent (.5%) of the total bid price, and the portion of the work which will be done by each such subcontractor.

NAME OF SUBCONTRACTOR	LOCATION OF BUSINESS	LICENSE NUMBER/ DIR REG. NUMBER	PORTION OF WORK
1) _____	_____	_____	_____
2) _____	_____	_____	_____
3) _____	_____	_____	_____
4) _____	_____	_____	_____
5) _____	_____	_____	_____
6) _____	_____	_____	_____
7) _____	_____	_____	_____
8) _____	_____	_____	_____
9) _____	_____	_____	_____
10) _____	_____	_____	_____

LIST OF PRIME CONTRACTOR AND SUBCONTRACTORS/SUPPLIERS

Bidder's Name: _____ Small Business Enterprise: Yes* ____ No ____
 Owner or Contact Person: _____ Title: _____
 Address: _____ Firm's Annual Gross Receipts**: _____ Age of Firm: _____
 Phone: (____) _____ Email: _____

*If yes, provide documentation showing the firm's current certification status.

* * * O p t i o n a l

List the following information for all subcontractors/suppliers that provided a bid, quote or proposal to the Bidder:

	Company Name/Address/Phone Owner's Name or Contact Person	SBE Non-SBE	Description of Work. Type of Materials/Supplies.	Dollar Amount of Work/Supplies	Bid/Quote Accepted? (Yes/No)
1					
2					
3					
4					
5					

The undersigned will enter into a formal agreement with the subcontractor(s) and/or supplier(s) whose bid/quote was accepted conditioned upon execution of a contract with County Connection. I certify that the information included on this form is complete and correct.

Signature of Owner or Authorized Representative

Title

Date

22273782.5

SELECTION PROCESS OF SUBCONTRACTORS/SUBCONSULTANTS/SUPPLIERS

Contract Name: _____ Bidder's Name: _____

Owner or Contact Person and Title: _____

Address: _____

Phone: _____ Email: _____

Firm Name	Contact Name	SBE/Other	Solicitation Method(s) (include attachments)	Results (include reasoning)
_____	_____	_____	_____	_____
_____	_____	_____	_____	_____
_____	_____	_____	_____	_____
_____	_____	_____	_____	_____
_____	_____	_____	_____	_____
_____	_____	_____	_____	_____
_____	_____	_____	_____	_____
_____	_____	_____	_____	_____
_____	_____	_____	_____	_____

Attach additional sheets as necessary.

Bidder hereby certifies that is was unable to subcontract to any SBE for this contract and has provided evidence of attempts to obtain SBE commitments.

Company Name: _____ Authorized Signature: _____

Title: _____ Date: _____

FAIR EMPLOYMENT PRACTICES CERTIFICATE

In connection with the performance of work under this Contract, the Contractor agrees as follows:

1. The Contractor will not willfully discriminate against any employee or applicant for employment because of race, color, religious creed, ancestry, national origin, sex, marital status, physical handicap, or medical condition, as defined in Government Code Section 12926. The Contractor will take affirmative action to ensure that applicants are employed, and that employees are treated during employment, without regard to their race, color, religious creed, ancestry, national origin, sex, physical handicap, or medical condition as defined in Government Code Section 12926. Such action shall include but not be limited to the following: employment, upgrading, demotion or transfer; recruitment or recruitment advertising; layoff or termination; rates of pay or other forms of compensation; and selection for training including apprenticeship. The Contractor agrees to post in conspicuous places, available to employees and applicants for employment, notices setting forth the provisions of this Fair Employment Practices section.

2. The Contractor will send to each labor union or representative of worker with which he has a collective bargaining agreement or other contract or understanding, a notice, advising the said labor union or workers' representative of the Contractor's commitments under this section, and shall post copies of the notice in conspicuous places available to employees and applicants for employment.

3. The Contractor will permit access to his records of employment, employment advertisements, application forms, and other pertinent data records by the Fair Employment and Housing Commission, the awarding authority or any other appropriate agency of the State of California designated by the awarding authority for the purposes of investigation to ascertain compliance with the Fair Employment Practices section of this Contract.

4. A finding of willful violation of the Fair Employment Practices section of this Contract or of the Fair Employment and Housing Act, Government Code Sections 12900 *et. seq.*, shall be regarded by the awarding authority as a basis for determining the Contractor to be not a "responsible Bidder" as to future contracts for which such Contractor may submit bids, for revoking the Contractor's prequalification rating, if any, and for refusing to establish, re-establish or renew a prequalification rating for the Contractor.

The awarding authority shall deem a finding of willful violation of the Fair Employment and Housing Act to have occurred upon receipt of written notice from the Fair Employment and Housing Commission that it has investigated and determined that the Contractor has violated the Fair Employment and Housing Act and has issued an order under Government Code Section 12970 or obtained an injunction under Government Code Section 12973.

Upon receipt of such written notice from the Department of Fair Employment and Housing, the awarding authority shall notify the Contractor that unless he demonstrates to the satisfaction of the awarding authority within a stated period that the violation has been corrected, his prequalification rating will be revoked at the expiration of such period.

5. The Contractor agrees that, should the awarding authority determine that the Contractor has not complied with the Fair Employment Practices section of this Contract, then pursuant to Labor Code Sections 1735 and 1775, the Contractor shall, as a penalty to the awarding authority, forfeit for each calendar day, or portion thereof, for each person who was denied employment as a result of such non-compliance, the penalties provided in the Labor Code for violation of prevailing wage rates. Such monies may be recovered from the Contractor. The awarding authority may deduct any such damages from any monies due the Contractor.

6. Nothing contained in the Fair Employment Practices section shall be construed in any manner or fashion so as to prevent the awarding authority from pursuing any other remedies that may be available at law.

7. The Contractor will include the provisions of the foregoing Paragraphs 1 through 6 in every first-tier subcontract, if any, so that such provisions will be binding upon each such subcontractor.

8. Statements and Payrolls. The Contractor shall maintain his records in conformance with the requirements in the Specification and the following provisions:

a. The submissions by the Contractor of payrolls, or copies thereof, is required. Each Contractor and subcontractor shall preserve his weekly payroll records for a period of three years from the date of completion of this Contract.

b. The payroll records shall contain the name, address, and social security number of each employee, his correct classification, rate of pay, daily and weekly number of hours worked, itemized deductions made and actual wages paid.

c. The Contractor shall make his payroll records available at the project site for inspection by the County Connection and shall permit the County Connection to interview employees during working hours on the job.

The following certification is to be executed by every Bidder and enclosed and forwarded in a sealed envelope containing the bid. The person signing the certification shall state his address and official capacity.

FAIR EMPLOYMENT PRACTICES CERTIFICATION

TO CENTRAL CONTRA COSTA TRANSIT AUTHORITY:

The undersigned, in submitting a bid for performing the following work by contract, hereby certifies that the Bidder will meet the above standards of affirmative compliance with the Fair Employment and Housing Act, Government Code Section 12900, *et. seq.*

	PRODUCT AND SERVICES
DATE	(TYPE) BIDDING COMPANY
ADDRESS NUMBER & STREET	BY SIGNATURE
CITY STATE ZIP CODE	(TYPE) NAME OF SIGNER
TELEPHONE	(TYPE) TITLE

WORKERS' COMPENSATION CERTIFICATION

By signing below, Bidder is aware of the provisions of Section 3700 of the Labor Code which requires every employer to be insured against liability for workers' compensation or to undertake self-insurance in accordance with the provision of that code, and if awarded a Contract, Bidder will comply with such provisions before commencing the performance of the work of this Contract.

_____ Firm Name

_____ Signature of Authorized Official

_____ Name of Authorized Official

_____ Title of Authorized Official

_____ Date

BIDDER'S STATEMENT OF QUALIFICATIONS AND BUSINESS REFERENCES

Name of Bidder _____

Address of Principal Office _____

1. Are you an individual _____, a partnership _____, a corporation _____ or a joint venture _____?
(Check as applicable)

If a partnership, list names and addresses of partners; if a corporation, list names of officers and directors and state of incorporation; if a joint venture, list names and addresses of venturers and if any venturer is a corporation, partnership or joint venture, list the same information for each such corporation, partnership and joint venture.

2. Are you licensed as a Contractor to do business in California? _____

License No. _____ Classification _____

Department of Industrial Relations (DIR) Registration No. _____

Note that the information provided above must evidence possession of a valid State of California Contractor's License, Type A-General Engineering and Type HAZ-Hazardous Substance Removal Certification.

For the following questions, if a joint venture, give information for each of the venturers, by name. Attach additional sheets if necessary.

3. How many years has your organization been in business as a Contractor under your present business name? _____

4. How many years of experience has your organization had in construction work similar to the work you are interested in bidding?

As a general contractor? _____

As a subcontractor? _____

5. Show all the projects your organization has completed during at least the last five years in the following tabulation. If your organization has been in existence for less than five years, show all the projects your key personnel have completed during the last five years in the following tabulation. (For joint venture work, show the sponsoring individual or company.) Attach additional sheets if necessary.

Year	Type of Work	Value of Work	Location	For Whom
------	--------------	---------------	----------	----------

6. Have you or your organization, or any officer or partner thereof, failed to complete a contract?

If so, give details. Attach additional sheets if necessary.

7. In what other lines of business are you financially interested? Attach additional sheets if necessary.

8. Name the persons with whom you have been associated in business as partners or business associates in each of the last five years. Attach additional sheets if necessary.

9. Give information below about the relevant experience of the principal individuals of your present organization including those individuals to be in responsible charge of this project. Attach additional sheets if necessary.

Individual's Name	Present Position of Office	Years of Construction Experience	Magnitude and Type of Work	In What Capacity
-------------------	----------------------------	----------------------------------	----------------------------	------------------

10. Give information below about all your contract work underway, or for which you are committed. Attach additional sheets if necessary.

Type of Work	Location	Value	Percent Complete	Scheduled Completion Date	For Whom Performed
--------------	----------	-------	------------------	---------------------------	--------------------

11. References: Give only engineers, architects, or owners, including public bodies, for whom you have done work. Attach additional sheets if necessary.

Name	Address	Business
_____	_____	_____
_____	_____	_____
_____	_____	_____

12. References: The following bank or banks can provide references as to the financial responsibility of the Bidder: Attach additional sheets if necessary.

A. Name of Bank: _____
Address: _____
City and State: _____ Telephone: _____
Officer Familiar with Bidder's Account: _____

B. Name of Bank: _____
Address: _____
City and State: _____ Telephone: _____
Officer Familiar with Bidder's Account: _____

C. Name of Bank: _____
Address: _____
City and State: _____ Telephone: _____
Officer Familiar with Bidder's Account: _____

13. References: The following surety company or companies can provide references as to the financial responsibility and general liability of the Bidder: Attach additional sheets if necessary.

A. Name of Surety Company: _____
Name of Local Agent (if different): _____
Local Address: Street _____
City and State: _____ Telephone: _____
Person Familiar with Bidder's Account: _____

B. Name of Surety Company: _____
Name of Local Agent (if different): _____
Local Address: Street _____
City and State: _____ Telephone: _____
Person Familiar with Bidder's Account: _____

14. Is any litigation pending against your organization? _____
If so, give details. Attach additional sheets if necessary.

The undersigned bidder represents and warrants that the foregoing information is true and accurate to the best of his/her knowledge and the undersigned intends that County Connection rely thereof in awarding the attached contract.

Signature of Bidder

Title

Dated: _____, 20____

CONTRACT
INSTALLATION OF ABOVE GROUND DIESEL FUEL STORAGE TANKS

This Contract is made and entered into by and between Central Contra Costa Transit Authority (County Connection), an entity formed under the California Joint Exercise of Powers Act, California Government Code Sections 6500, *et seq.*, and _____ (Contractor), a corporation in good standing under the laws of the State of California, as of this _____ day of _____, 20____.

RECITALS

WHEREAS, County Connection desires to engage a contractor to perform the Installation of Above Ground Diesel Fuel Storage Tanks project, as set forth in Exhibit A and incorporated herein; and

WHEREAS, the Contractor desires to furnish such work, and has submitted a bid dated _____, 20____, incorporated herein as Exhibit B.

NOW THEREFORE, THE PARTIES AGREE AS FOLLOWS:

- 1. INCORPORATION BY REFERENCE.** The following documents are hereby incorporated herein by this reference:

Notice Inviting Sealed Bids, Instructions to Bidders and General Conditions, Public Works Provisions, Technical Specifications, including Drawings, and Addenda (if any are issued). Copies of said documents are attached hereto as Exhibit A.

Contractor's Bid forms, as accepted by County Connection. Copies of said documents are attached hereto as Exhibit B. In the event of any conflicts or inconsistencies the following order of precedence shall govern the interpretation of the contract documents:

A. Exhibit A (consisting of Notice Inviting Sealed Bids, Instructions to Bidders and General Conditions, Public Works Provisions, Technical Specifications, including Drawings, and Addenda, if any are issued);

B. Exhibit B (Contractor's Bid Form).

- 2. SCOPE OF WORK.** The Contractor shall perform all the work and furnish all the labor, materials, tools, services, and equipment required to complete the Installation of Above Ground Diesel Fuel Storage Tanks at County Connection's Concord facility located at located at 2477 Arnold Industrial Way, Concord, CA 94520, as more particularly described in Exhibit A. Contractor agrees to provide services to County Connection in accordance with the terms and conditions of this Contract. In the performance of its work, the Contractor represents that it (1) has and will exercise the degree of care, skill, efficiency, and judgment of contractors with special expertise in the Installation of Above Ground Diesel Fuel Storage Tanks; (2) carries all applicable licenses, certificates, and registrations in current and good standing that may be required to perform the work; and (3) will retain all such licenses, certificates, and registrations in active status throughout the duration of this engagement.
- 3. BEGINNING OF WORK AND TIME OF COMPLETION.** After the Contract has been executed by County Connection, and all insurance and bonding documentation has been received by County Connection, the Contractor shall begin work within thirty (30) days following the receipt date on the Notice to Proceed, and shall complete all of the work called for under this Contract within sixty (60) calendar days from the commencement of work or by June 30, 2026, whichever comes sooner.

4. **COMPENSATION.** The Contractor shall faithfully perform all of the work required under this Contract for a total sum of \$ _____, as more particularly described in the cost proposal attached and incorporated as Exhibit B (Total Contract Price). The Total Contract Price shall include any and all costs for materials, labor, subcontractors, insurance, taxes, delivery, profit, bonding, warranty and any other element of expense or compensation arising out of the work performed hereunder.
5. **MANNER OF PAYMENT.** Upon County Connection's final acceptance of the complete work, Contractor shall submit an invoice to County Connection. No progress payments will be considered on this project.

County Connection will pay approved invoices/billing statements within 60 calendar days of their receipt. County Connection reserves the right to withhold payment to the Contractor if County Connection determines that the quantity or quality of the work performed is unacceptable. County Connection shall provide written notice to the Contractor within ten (10) business days of County Connection's decision not to pay and the reasons for non-payment.

Invoices should be sent to: County Connection, Attention Accounts Payable, 2477 Arnold Industrial Way, Concord, CA 94520 or by email to AP@cccta.org.

6. **INSPECTION OF SITE OF WORK.** Contractor shall examine carefully the site of work and shall inform itself of the conditions relating to the execution of the work. If the Contractor does not inspect the site, the Contractor is responsible for all site conditions had the Contractor performed a reasonable site inspection.
7. **INSURANCE.**

(a) Types of Insurance

(1) Workers' Compensation. If Contractor employs any person to perform work in connection with this Contract, Contractor shall procure and maintain at all times during the performance of such work Workers' Compensation Insurance in conformance with the laws of the State of California and Federal laws where applicable. Employers' Liability Insurance shall not be less than One Million Dollars (\$1,000,000) per accident or disease. Prior to commencement of work under this Contract by any such employee, Contractor shall deliver to County Connection a Certificate of Insurance that shall stipulate that 30 days' advance written notice of cancellation, non-renewal or reduction in limits shall be given to County Connection.

The policy shall contain a waiver of subrogation in favor of the Central Contra Costa Transit Authority and its directors, officers, representatives, agents and employees.

(2) Commercial General and Automobile Liability Insurance

(A) Commercial General Liability Insurance. Contractor shall, at its own cost and expense, also procure and maintain Commercial General Liability insurance providing bodily injury and property damage coverage with a combined single limit for a minimum of \$1 million each occurrence and a general aggregate limit for a minimum of \$2 million. This insurance shall include but not be limited to premises and operations; contractual liability covering the indemnity provisions contained in this Contract; personal injury; products and completed operations, advertising injury liability, and broad form property damage.

(B) Automobile Liability. Contractor shall, at its own cost and expense, procure and maintain Automobile Liability insurance providing bodily injury and property damage with a combined single limit for a minimum of \$1 million per occurrence for all owned, non-

owned and hired automobiles. This insurance shall provide contractual liability covering all motor vehicles and mobile equipment to the extent coverage may be excluded from general liability insurance.

(C) Umbrella or Excess Liability. Contractor shall, at its own cost and expense, also procure and maintain either a commercial Umbrella or Excess Liability with limits no less than \$2,000,000. Umbrella or Excess policies shall follow form over the General Liability, Auto Liability and Employers Liability.

(D) Builders Risk (Course of Construction) or Installation Floater. "All Risk" Builder's Risk (Course of Construction) or Installation Floater to insure all operations from the start of construction until final completion. The limit must equal the total value of the completed project and no coinsurance penalty provision.

(E) Contractor's Pollution Legal Liability and/or Asbestos Legal Liability and/or Errors and Omissions (if project involves environmental hazards) with limits no less than \$1,000,000 per occurrence or claim, and \$2,000,000 policy aggregate.

(F) Prior to commencing work or entering onto the property, Contractor shall file a Certificate of Insurance with County Connection evidencing the foregoing coverages, including the following endorsements, which are mandatory:

(i) The insurance company(ies) issuing such policy(ies) shall give written notice to County Connection of any material alteration, or reduction in aggregate limits, if such limits apply, and provide at least thirty (30) days' notice of cancellation.

(ii) All policies shall contain a Waiver of Subrogation in favor of the Central Contra Costa Transit Authority and its directors, officers, representatives, agents and employees.

(iii) That the policy(ies) is Primary Insurance and the insurance company(ies) providing such policy(ies) shall be liable thereunder for the full amount of any loss or claim which Contractor is liable for under this section, up to and including the total limit of liability, without right of contribution from any other insurance effected or which may be effected by County Connection, with an exception to Workers' Compensation policy.

(iv) Such insurance shall include as additional insured the Central Contra Costa Transit Authority and its respective directors, officers, employees and agents while acting in such capacity, and their successors or assignees, as they now or as they may hereafter be constituted, singly, jointly or severally. Inclusion of County Connection as additional named insured shall not in any way affect its rights either as respects any claim, demand, suit or judgment made, brought or recovered against the Contractor. Said policy shall protect Contractor and County Connection in the same manner as though a separate policy had been issued to each, but nothing in said policy shall operate to increase the insurance company's liability as set forth in its policy beyond the amount or amounts shown or to which the insurance company would have been liable if only one interest had been named as an insured.

(v) All coverage shall be placed with an insurance company whose A.M. Best's rating is no less than A-, and an A.M. Best's financial rating of not less than VIII.

- 8. FINAL INSPECTION AND ACCEPTANCE.** Upon notice from the Contractor that the work has been completed, County Connection will make a final inspection and provide the Contractor with written notice of final acceptance, if it is determined that the work meets the Contract requirements, or instructions to promptly fix defective work at Contractor's sole expense.

- 9. GUARANTY OF WORK.** Contractor warrants to County Connection that all materials and equipment furnished under the Contract will be of good quality and new, that the work will be free from defects in material or workmanship, and that the work will conform to the requirements of the Contract. Work not conforming to the Contract requirements may be considered defective.

If, within three (3) years after the date of final acceptance of the work by County Connection, any of the work is found to be defective, the Contractor shall correct it promptly after written notice from County Connection to do so and pay for any damage to other property resulting from the defective work. If the Contractor fails to correct the defective work, County Connection may correct it at the Contractor's expense. Work that is corrected shall be subject to a three-year warranty obligation, commencing on the date the work is corrected and accepted by County Connection.

The requirements of this section relate only to the specific obligation to correct defective work and nothing in this section shall be construed to establish a period of limitation with respect to other obligations of Contractor under the Contract.

- 10. CONDITIONS OF USE AND PRESERVATION OF PROPERTY.** Contractor shall assume full responsibility for protection and safekeeping of the materials and equipment stored on the site. In the event that any stored items or activities of the Contractor interfere with County Connection's operations, the Contractor shall move the items or modify the activities at its expense in accordance with County Connection's direction.

Contractor shall exercise due care to avoid injury to existing improvements or facilities, utility facilities and adjacent property. Any injury to the property of County Connection or any other third party caused by Contractor's operations shall be restored or replaced at Contractor's expense.

11. LIQUIDATED DAMAGES. If the Contractor fails to complete the work within the time limit set forth herein, or as may be modified in accordance with this Contract, damage will be sustained by County Connection and it will be impracticable and difficult to ascertain the actual damage County Connection will sustain in the event of such delay. It is therefore agreed that Contractor shall pay liquidated damages for delay (not as a penalty) in the amount of \$500.00 per day until the work is completed. Contractor agrees to pay these liquidated damages, and further agrees that County Connection may deduct this amount from monies due or that may become due Contractor if not paid within seven (7) days of demand by County Connection.

The Contractor will be granted an extension of time and will not be assessed liquidated damages for any delay in the completion of the work caused by unforeseeable causes beyond Contractor's reasonable control and without fault of the Contractor as determined by County Connection. Contractor shall notify County Connection, in writing, within ten (10) days from the beginning of such delay specifying the nature of the delay and the number of days delayed. Failure to submit written notice shall constitute an absolute waiver of any claim for an extension of time and shall be sufficient cause for denial of a request for an extension.

12. COMPLIANCE WITH ALL APPLICABLE LAWS. Contractor shall comply with all the applicable requirements of federal, state and local laws, statutes and ordinances relative to the execution of the work. In the event Contractor fails to comply with these requirements, County Connection may stop any work until such noncompliance is remedied. No part of the time lost due to any such cessation of the work shall be made the subject of a claim for an extension of time or increase in the compensation.

13. CONTRACTOR'S STATUS. Neither Contractor nor any party contracting with the Contractor shall be deemed an agent or employee of County Connection. The Contractor is and shall be an independent contractor, and the legal relationship of any person performing services for Contractor shall be one solely between said parties.

14. ASSIGNMENT. Contractor shall not assign any of its rights nor transfer any of its obligations under this Contract without the prior written consent of County Connection.

15. RECORDS. During the term of this Contract, and for a period of four years after completion of the Contract, Contractor shall permit representatives of County Connection to have access to, examine and make copies, at County Connection's expense, of its books, records and documents relating to this Contract at all reasonable times.

16. COUNTY CONNECTION WARRANTIES. County Connection makes no warranties, representations, or agreements, either express or implied, beyond such as are explicitly stated herein.

17. COUNTY CONNECTION REPRESENTATIVE. Except when approval or other action is required to be given or taken by the Board of Directors of County Connection, the General Manager of County Connection, or the General Manager's designee, shall represent and act for County Connection.

18. NOTICES. All notices and communications deemed by either party to be necessary or desirable to be given to the other party shall be in writing and may be given by personal delivery to a representative of the parties or by mailing the same postage prepaid, addressed as follows:

If to County Connection: County Connection
2477 Arnold Industrial Way
Concord, CA 94520

Attention: Amber Johnson, CFO

If to the Contractor: _____

Attention: _____

The address to which mailings may be made may be changed from time to time by notice mailed as described above. Any notice given by mail shall be deemed given on the day after that on which it is deposited in the United States Mail as provided above.

19. ATTORNEYS' FEES. If any legal proceeding should be instituted by either of the parties hereto to enforce the terms of this Contract or to determine the rights of the parties thereunder, the prevailing party in said proceeding shall recover, in addition to all court costs, reasonable attorneys' fees.

20. APPLICABLE LAW. This Contract, its interpretation and all work performed thereunder, shall be governed by the laws of the State of California.

21. INTEGRATION. It is expressly agreed between the County Connection and the Contractor that this agreement expresses the complete agreement between said parties and supersedes all prior oral or written negotiations, agreements and understandings between them regarding the subject matter of this contract.

22. BINDING ON SUCCESSORS. All of the terms, provisions and conditions of this Contract shall be binding upon and inure to the benefit of the parties hereto and their respective successors, assigns and legal representatives.

23. WAIVER. Any waiver of any breach or covenant of this Agreement must be in a writing executed by a duly authorized representative of the party waiving the breach. A waiver by any of the parties of a breach or covenant of this Agreement shall not be construed to be a waiver of any succeeding breach or any other covenant unless specifically and explicitly stated in such waiver.

24. SEVERABILITY. If any provision of this Agreement shall be deemed invalid or unenforceable, that provision shall be reformed and/or construed consistently with applicable law as nearly as possible to reflect the original intentions of this Agreement, and in any event, the remaining provisions of this Agreement shall remain in full force and effect.

25. NO THIRD PARTY BENEFICIARIES. This Agreement is not for the benefit of any person or entity other than the parties.

IN WITNESS WHEREOF, the parties hereto have executed this Contract by their duly authorized officers as of the day and year first above written.

COUNTY CONNECTION

CONTRACTOR

By: _____

*By: _____

Name: _____

Name: _____

Title: _____

Title: _____

By: _____

Name: _____

ATTEST:

Title: _____

Secretary for COUNTY CONNECTION

APPROVED AS TO FORM

Attorney for COUNTY CONNECTION

**If Contractor is a corporation, the Contract must be executed by two corporate officers, one from each of the following categories 1) the President, the Vice President or the Chair of the Board, and 2) the Secretary, Assistant Secretary, Chief Financial Officer, or Assistant Treasurer.*

PUBLIC WORKS PROVISIONS

1. Prohibition Against Contracting with Debarred Subcontractors. Contractors are prohibited from performing work on a public works project with a subcontractor who is ineligible to perform work on the public works project pursuant to Section 1777.1 or 1777.7 of the Labor Code.
2. Use Of Subcontractors. Contractor shall not subcontract any work to be performed by it under this Contract without the prior written approval of County Connection. Contractor shall be solely responsible for reimbursing any subcontractors and County Connection shall have no obligation to them. Attention is directed to the requirements of Sections 4100 to 4113, inclusive, of the California Public Contract Code which are applicable to this Contract. Each Contractor shall list the name and business address of each subcontractor to whom the Contractor proposes to subcontract a portion of the work in an amount in excess of one-half of one percent (.5%) of the Total Contract Price, along with a description of the portion of the work which shall be done by each subcontractor, by executing the "List of Subcontractors" form attached to this Contract.
3. Prompt Payment to Subcontractors. Contractor shall pay any subcontractors approved by County Connection for work that has been satisfactorily performed no later than seven (7) days from the date of Contractor's receipt of payments by County Connection. In the event Contractor does not make payments to the subcontractors in accordance with the time period in this section, Contractor will be subject to a charge of two percent (2%) per month on the untimely or improperly withheld payment.
4. Non-Collusion Declaration. Pursuant to Public Contract Code section 7106, Contractor shall execute a Non-Collusion Declaration, in a form provided by County Connection, which is attached and incorporated herein.
5. Assignment of Claims. In entering into a public works contract or a subcontract to supply goods, services, or materials pursuant to a public works contract, the Contractor or subcontractor offers and agrees to assign to the awarding body all rights, title, and interest in and to all causes of action it may have under Section 4 of the Clayton Act (15 U.S.C. Sec. 15) or under the Cartwright Act (Chapter 2 (commencing with Section 16700) of Part 2 of Division 7 of the Business and Professions Code), arising from purchases of goods, services, or materials pursuant to the public works contract or the subcontract. This assignment shall be made and become effective at the time the awarding body tenders final payment to the Contractor, without further acknowledgement by the parties.
6. Third-Party Claims.
 - a. Pursuant to Public Contracts Code Section 9201, County Connection shall have full authority to compromise or otherwise settle any claim relating to the Contract at any time.
 - b. County Connection shall provide for timely notification to the Contractor of the receipt of any third-party claim, relating to the contract. Notice shall be in writing and will be provided within thirty (30) days.
 - c. County Connection shall be entitled to recover its reasonable costs incurred in providing the notification required by subdivision (b).
7. Claims Procedures. Compliance with all change order procedures is a prerequisite to filing a Public Contract Code Claim pursuant to this section. Claims must be submitted no later than (a) 30 days after contract adjustment procedures under General Conditions 32 are concluded, or (b) 30 days after the occurrence of the event giving rise to the claim.

In accordance with the procedures set forth in Public Contract Code sections 9204 and 20104-20104.6, a Contractor may submit a claim by registered or certified mail with return receipt requested, for one or more of the following: (a) a time extension, including, without limitation, for relief from damages or penalties for delay assessed by County Connection; (b) payment by County Connection of money or damages arising from work done by, or on behalf of, the Contractor pursuant to this contract and payment for which is not otherwise expressly provided or to which the Contractor is not otherwise entitled; or (c) payment of an amount that is disputed by County Connection.

The Contractor shall furnish reasonable documentation with the claim, including but not limited to: 1) a clear, concise recital of the basis upon which the claim is asserted, including a designation of the provisions of the Contract Documents upon which the claim is based, 2) a statement as to the amount of time and/or compensation sought pursuant to the claim; 3) whether the Contractor's claim arises from an ongoing occurrence, and if so a description of the specific Work activities affected by the claim, 4) a time impact analysis in the event that Contractor requests a time extension, 5) full and complete cost records supporting the amount of any claim for additional compensation, and 6) a notarized certification by the Contractor as follows: "Under the penalty of law for perjury or falsification and with specific reference to the California False Claims Act, Government Code Section 12650 et seq., the undersigned hereby certifies that the information contained herein is a true, accurate and complete statement of all features relating to the claim asserted." Failure by the Contractor to provide sufficient documentation to support the claim will result in denial of the claim. County Connection reserves the right to request additional documentation, or clarification of the documentation provided.

Upon receipt of a claim, County Connection will conduct a reasonable review and provide a written statement to the Contractor identifying what portion of the claim is disputed and what portion is undisputed within 45 days of receipt of the claim. County Connection and Contractor may, by mutual agreement, extend the 45 day time period. For any undisputed portion of a claim, County Connection must make payment within 60 days of its issuance of the written statement.

If the Contractor disputes County Connection's written statement, or if County Connection fails to respond, the Contractor may demand an informal conference to meet and confer for settlement of the issues in dispute. County Connection will then schedule the meet and confer conference within 30 days of the demand. Within 10 business days following the meet and confer conference, County Connection will provide a written statement identifying the portion of the claim that remain in dispute. Any payment due on an undisputed portion of the claim will be made within 60 days of the meet and confer conference.

After the meet and confer conference, any disputed portion of the claim shall be submitted to non-binding mediation. Alternatively, upon receipt of a claim, the parties may mutually agree to waive, in writing, mediation and proceed directly to the commencement of a civil action or binding arbitration, as applicable. If mediation is unsuccessful, the parts of the claim that remain in dispute shall be subject to applicable procedures set forth below.

Failure of a public entity to respond to a claim within the time periods described above shall result in the claim being deemed rejected in its entirety. Additionally, amounts not paid in a timely manner shall bear interest at 7 percent per year.

In the event that the mediation is unsuccessful, Contractor must file a government claim pursuant to Government Code section 910 et seq. in order to initiate a civil action.

In any civil action filed to resolve claims, the court shall submit the matter to nonbinding mediation within 60 days following the filing or responsive pleading, provided that the parties have not already participated in mediation of the claim as outlined above. If the matter remains in dispute after nonbinding mediation, the court shall submit the matter to judicial arbitration

pursuant to Code of Civil Procedure section 1141.10 et seq. If the matter remains in dispute after judicial arbitration, County Connection or the Contractor may request a trial de novo.

8. Utility Relocation. Pursuant to California Government Code Section 4215, if during the course of the work the Contractor encounters utility installations which are not shown or indicated in the contract plans or in the specifications or which are found in a location substantially different from that shown, and such utilities are not reasonably apparent from visual examination of the work site, then it shall promptly notify County Connection in writing. Where necessary for the work of the Contract, County Connection will amend the contract to adjust the scope of work and the compensation to allow the Contractor to make such adjustment, rearrangement, repair, removal, alteration, or special handling of such utility, including repair of the damaged utility. If the Contractor fails to give the notice specified above and thereafter acts without instructions from County Connection, then it shall be liable for any or all damage to such utilities or other work of the Contract which arises from its operations subsequent to the discovery, and it shall repair and make good such damage at its own cost.
9. Excavation. In accordance with state law (Public Contract Code Section 7104), with respect to any work involving digging trenches or excavations that extend deeper than four feet, the Contractor shall notify County Connection promptly in writing of any of the following conditions: (a) material that the Contractor believes may be hazardous waste, as defined in California Health and Safety Code Section 25117, that is required to be removed to a Class I, Class II or Class III disposal site in accordance with provisions of existing law; (b) subsurface or latent physical conditions at the site differing from those indicated; (c) unknown physical conditions at the site of any unusual nature, differing materially from those ordinarily encountered and generally recognized as inherent in work of the character provided for in the Contract Documents. Contractor shall notify County Connection of such conditions prior to disturbing them, and shall await direction from County Connection as to how to proceed. If the Contractor fails to promptly notify County Connection, it waives its claim of a differing site condition for the period between its discovery of the differing site condition and its notification to County Connection. If the Contractor disturbs the site after discovery and before County Connection's investigation, it waives the differing-site condition claim.
10. Trench Safety. Excavation for any trench 5 feet or more in depth shall not begin until the Contractor has received approval from County Connection, of the Contractor's detailed plan for worker protection from the hazards of caving ground during the excavation of such trench. Such plan shall be submitted at least 5 days before the Contractor intends to begin excavation for the trench and shall show the details of the design of shoring, bracing, sloping or other provisions to be made for worker protection during such excavation. No such plan shall allow the use of shoring, sloping or a protective system less effective than that required by the Construction Safety Orders of the Division of Industrial Safety; and if such plan varies from the shoring system standards established by the Construction Safety Orders, the plan shall be prepared and signed by an engineer who is registered as a Civil or Structural Engineer in the State of California. Attention is directed to the provisions of Section 6705 of the Labor Code concerning trench excavation safety plans.
11. Payment Bond. For all contracts over \$25,000, the successful Bidder shall provide a payment bond in the amount equal to one hundred percent (100%) of the Total Contract Price and issued by a California admitted surety. The payment bond shall provide County Connection with security for Contractor's full payment to all subcontractors for costs of materials, equipment, supplies, and labor furnished in the course of the performance of the Contract. Full compensation for furnishing the payment bond is included in the Total Contract Price.
12. Contractor's License Requirements and Public Works Registration. Contractor and any approved subcontractors shall hold such current and valid Contractor's Licenses as required by California law. No Contractor or subcontractor may be listed on a bid unless registered with the Department

of Industrial Relations pursuant to Labor Code Section 1725.5. This Contract is subject to monitoring and enforcement by the DIR pursuant to Labor Code Section 1771.4. The Contractor shall furnish the records specified in Labor Code Section 1776 directly to the Labor Commissioner, monthly in a format prescribed by the Labor Commissioner.

13. Labor Code Requirements. In the performance of this Contract, Contractor's attention is directed to the following requirements of the Labor Code:

- A. Hours of Labor. Eight hours labor constitutes a legal day's work. Contractor shall forfeit, as penalty to County Connection, \$25 for each worker employed in the performance of the Contract by Contractor or by any subcontractor under it for each calendar day during which such worker is required or permitted to work more than eight hours in any one day and 40 hours in any one calendar week in violation of the provisions of the California Labor Code and in particular, Sections 1810 to 1815, inclusive. Work performed by employees of the Contractor in excess of eight hours per day and 40 hours during any one week shall be permitted upon compensation for all hours worked in excess of eight hours per day at not less than one-and-one-half times the basic rate of pay, as provided in Section 1815.
- B. Prevailing Wages. Contractor shall comply with California Labor Code Sections 1770 to 1780, inclusive. In accordance with Section 1775, the Contractor shall forfeit as a penalty to County Connection an amount as determined by the Labor Commissioner not to exceed \$200 for each calendar day or portion thereof for each worker paid less than stipulated prevailing wage rates for such work or craft in which such worker is employed for any work done under the contract by him or by any subcontractor under it in violation of the revisions of the Labor Code and in particular, Labor Code Sections 1770 to 1780, inclusive. In addition to said penalty and pursuant to Section 1775, the difference between such stipulated prevailing wage rates and the amount paid to each worker for each calendar day or portion thereof for which each worker was paid less than the stipulated prevailing wage rate shall be paid to each worker by Contractor. Pursuant to the provisions of Section 1773 of the Labor Code, County Connection has obtained the general prevailing rate of per diem wages and the general prevailing rate for holiday and overtime work applicable to the work to be done from the Director of the Department of Industrial Relations. Copies of the prevailing wage rates are on file at County Connection and are available for review upon request.

Pursuant to §1773.2 of the Labor Code, the Contractor shall post general prevailing wage rates at a prominent place at the site of the work.

This Contract is subject to monitoring and enforcement by the Department of Industrial Relations, pursuant to Labor Code Section 1771.4. The Contractor must post job site notices, as prescribed by regulation. The Contractor and all Subcontractors shall furnish the records specified in Labor Code Section 1776 directly to the Labor Commissioner, monthly in a format prescribed by the Labor Commissioner.

If a worker employed by a subcontractor on a Public Works Project is not paid the general prevailing per diem wages by the subcontractor, Contractor of the Project is not liable for the penalties described above unless Contractor had knowledge of that failure of the subcontractor to pay the specified prevailing rate of wages to those workers or unless Contractor fails to comply with all of the following requirements:

- 1) The Contract executed between Contractor and the subcontractor for the performance of work on Public Works Project shall include a copy of the requirements in Sections 1771, 1775, 1776, 1777.5, 1813 and 1815 of the Labor Code.

- 2) Contractor shall monitor the payment of the specified general prevailing rate of per diem wages by the subcontractor to the employees by periodic review of the certified payroll records of the subcontractor.
- 3) Upon becoming aware of the subcontractor's failure to pay the specified prevailing rate of wages to the subcontractor's workers, Contractor shall diligently take corrective action to halt or rectify the failure, including, but not limited to, retaining sufficient funds due the subcontractor for work performed on the Public Works Project.
- 4) Prior to making final payment to the subcontractor for work performed on the Public Works Project, Contractor shall obtain an affidavit signed under penalty of perjury from the subcontractor that the subcontractor has paid the specified general prevailing rate of per diem wages to the subcontractor's employees on the Public Works Project and any amounts due pursuant to Section 1813 of the Labor Code.

Pursuant to Section 1775 of the Labor Code, the Division of Labor Standards Enforcement shall notify Contractor on a Public Works Project within fifteen (15) days of the receipt by the Division of Labor Standards Enforcement of a complaint of the failure of a subcontractor on that Public Works Project to pay workers the general prevailing rate of per diem wages. If the Division of Labor Standards Enforcement determines that employees of a subcontractor were not paid the general prevailing rate of per diem wages and if County Connection did not retain sufficient money under the Contract to pay those employees the balance of wages owed under the general prevailing rate of per diem wages, Contractor shall withhold an amount of money due the subcontractor sufficient to pay those employees the general prevailing rate of per diem wages if requested by the Division of Labor Standards Enforcement. Contractor shall pay any money retained from and owed to a subcontractor upon receipt of notification by the Division of Labor Standards Enforcement that the wage complaint has been resolved. If notice of the resolution of the wage complaint has not been received by Contractor within one hundred eighty (180) days of the filing of a valid notice of completion or acceptance of the Public Works Project, whichever occurs later, Contractor shall pay all monies retained from the subcontractor to County Connection. These monies shall be retained by County Connection pending the final decision of an enforcement action.

- C. Payroll Records. The Contractor's attention is directed to the following provisions of Labor Code Section 1776. The Contractor shall be responsible for the compliance with these provisions by his subcontractors.
- i. Each contractor and subcontractor shall keep an accurate payroll record, showing the name, address, social security number, work classification, straight time and overtime hours worked each day and week, and the actual per diem wages paid to each journeyman, apprentice, worker, or other employee employed by him or her in connection with the public work.
 - ii. The payroll records enumerated under subdivision (a) shall be certified and shall be available for inspection at all reasonable hours at the principal office of the Contractor on the following basis:
 - a. A certified copy of an employee's payroll record shall be made available for inspection or furnished to such employee or his or her authorized representative on request.

- b. A certified copy of all payroll records enumerated in subdivision (a) shall be made available for inspection or furnished upon request to County Connection, the Division of Labor Standards Enforcement and the Division of Apprenticeship Standards of the Department of Industrial Relations.
 - c. A certified copy of all payroll records enumerated in subdivision (a) shall be made available upon request to the public for inspection or copies thereof made; provided, however, that a request by the public shall be made through either County Connection, the Division of Apprenticeship Standards or the Division of Labor Standards Enforcement. If the requested payroll records have not been provided pursuant to paragraph (2), the requesting party shall, prior to being provided the records, reimburse the costs of preparation by the Contractor, subcontractor and the entity through which the request was made. The public shall not be given access to such records at the principal office of the Contractor.
 - iii. The certified payroll records shall be on forms provided by the Division of Labor Standards Enforcement or shall contain the same information as the forms provided by the Division.
 - iv. The Contractor shall file a certified copy of the records enumerated in subdivision (a) with the entity that requested such records within ten (10) days after receipt of a written request.
 - v. Any copy of records made available for inspection as copies and furnished upon request to the public or County Connection, the Division of Apprenticeship Standards or the Division of Labor Standards Enforcement shall be marked or obliterated in such a manner as to prevent disclosure of an individual's name, address and social security number. The name and address of the Contractor shall not be marked or obliterated.
 - vi. The Contractor shall inform County Connection of the location of records enumerated under subdivision (a), including the street address, city and county, and shall, within five (5) working days, provide a notice of a change of location and address.
 - vii. In the event of noncompliance with the requirements of this Section, the Contractor shall have ten (10) days in which to comply subsequent to receipt of written notice specifying in what respects such contractor must comply with this Section. Should noncompliance still be evident after such 10-day period, the Contractor shall, as a penalty the State or County Connection, forfeit \$100 for each calendar day, or portion thereof, for each worker, until strict compliance is effectuated. Upon the request of the Division of Apprenticeship Standards or the Division of Labor Standards Enforcement, such penalties shall be withheld from progress payments then due. The penalties specified in subdivision (g) of Labor Code Section 1776 for noncompliance with the provisions of said Section 1776 may be deducted from any monies due or which may become due to the Contractor.
 - viii. The Contractor and each subcontractor shall preserve their payroll records for a period of three (3) years from the date of completion of the Contract.
- D. Labor Non-discrimination. Attention is directed to Section 1735 of the Labor Code which provides that Contractor shall not discriminate against any employee or applicant

for employment because of race, religious creed, color, national origin, ancestry, physical disability, mental disability, medical condition, genetic information, marital status, sex, gender, gender identity, gender expression, age, or sexual orientation of such persons, except as provided in Section 12940 of the Government Code. Contractor further agrees to include a similar provision in all subcontracts, except subcontracts for standard commercial supplies or raw materials.

- E. Apprentices. The Contractor and all subcontractors shall comply with the requirements of California Labor Code sections 1777.5, 1777.6 and 1777.7 regarding the employment and of apprentices.
14. Payment of Workers' Compensation. Each Contractor to whom a public works contract is awarded shall sign and file with County Connection the following certification, provided with the Bid Forms, prior to performing the work of the contract:
- “I am aware of the provisions of Section 3700 of the Labor Code which requires every employer to be insured against liability for workers' compensation or to undertake self-insurance in accordance with the provisions of that code, and I will comply with such provisions before commencing the performance of the work of this Contract.”
15. Examination and Audit of Records (Gov. Code section 8546.7). Pursuant to Government Code Section 8546.7, Contractor shall retain all project-related records for a period of 3 years after final payment on this contract, which shall be subject to audit or inspection by County Connection or the State Auditor during this period. Separate and apart from the obligations under Section 8546.7, the County Connection will have the right to audit project records at County Connection discretion under the following circumstances: (a) submission of a Public Records Act request regarding the project; (b) inability to resolve a disputed Agreement change order; or (c) submission of a construction claim.
16. Notice of Taxable Possessory Interest (Rev. and Taxation Code section 107.6). In accordance with Revenue and Taxation Code Section 107.6, the Contract Documents may create a possessory interest subject to personal property taxation for which the Contractor will be responsible.
17. Antitrust Claim Assignment. In entering into an Agreement or a subcontract to supply goods, services, or materials pursuant to this Contract, the Contractor or subcontractor offers and agrees to assign to the County Connection all rights, title, and interest in and to all causes of action it may have under Section 4 of the Clayton Act (15 U.S.C. Sec. 15) or under the Cartwright Act (Chapter 2 (commencing with Section 16700) of Part 2 of Division 7 of the Business and Professions Code), arising from purchases of goods, services, or materials pursuant to this Agreement or a subcontract. This assignment will be made and become effective at the time the awarding body tenders final payment to the Contractor, without further acknowledgment by the parties.
18. Coordination With Federal and California Prevailing Wage Laws. When both Federal and California Prevailing Wage Laws apply to the Agreement, the Contractor and any subcontractor shall pay their workers the higher of the two prevailing wage rates. To the extent that contract provisions required by Federal and State law are inconsistent, the Contractor is responsible for complying with the more comprehensive or stricter requirements. The Contractor and all subcontractors shall insert this clause in any lower-tier contract. Federal prevailing wage rate, if applicable, are contained in a separate section.
19. Permits, Licenses, Training. The Contractor shall procure all permits, licenses, certifications, and training (including OSHA permits pursuant to Labor Code Section 6500), pay all charges and fees, and give all notices necessary and incident to the due and lawful prosecution of the work.

The Environmental Quality Act (Public Resources Code, Section 21000 to 21176) may be applicable to permits, licenses and other authorizations which the Contractor must obtain from State or local agencies in connection with performing the work of the Contract. The Contractor shall comply with the provisions of that Act in obtaining such permits, licenses and other authorizations and they shall be obtained in sufficient time to prevent delays to the work. The Contractor shall comply with permits obtained by the County Connection, if any, for the work.

For all work to be performed on surfaces coated with any detectable level of lead, and to the extent applicable, the Contractor must comply with Cal/OSHA Construction Safety Orders, Lead, Section 1532.1; California Code of Regulations, Titles 8 and 17; and the EPA's Lead-Based Paint Renovation, Repair and Painting (RRP) Rule. To the extent applicable, the Contractor, and any subcontractors, must ensure workers possess all required California Department of Public Health certifications in accordance with California Code of Regulations, Title 17, Section 35001 et seq. and California Code of Regulations, Title 8, Section 1532.1.

- 20.** Wage Kickbacks and Worker Registration Fees Prohibited. The Contractor and subcontractors at any tier shall comply with Labor Code sections 1778 through 1779. The Contractor and subcontractors shall not take, receive, or conspire with another to take or receive, for their own use or the use of any other person any portion of the wages of any worker or subcontractor in connection with this Agreement. The Contractor and subcontractors shall not charge, collect, or attempt to charge or collect, directly or indirectly, a fee or valuable consideration for registering any person to work in connection with the Agreement, or for giving information as to where such employment may be procured, or for placing, assisting in placing, or attempting to place, any person in connection with the Agreement.

INSTRUCTIONS TO BIDDERS AND GENERAL CONDITIONS

- 1. DEFINITION OF TERMS.** Whenever in the bid or Contract Documents the following terms or pronouns in place of them, or abbreviations, are used, the intent and meaning shall be interpreted as follows:

"Central Contra Costa Transit Authority" or "County Connection" means Central Contra Costa Transit Authority.

"Board", "Directors" or "Board of Directors" means Central Contra Costa Transit Authority Board of Directors.

"General Manager" means the General Manager of Central Contra Costa Transit Authority or his properly authorized representative or agent.

"Contractor" means the successful bidder to whom a contract is awarded.

"Written Order" means a written order signed by the General Manager, or his properly authorized representative or agent, mailed to the Contractor at the address designated in its bid or to such other address as it may designate in writing as its official place of business.

"Bid Documents", "Bid Forms", "Contract Documents" and cognate terms mean the Notice, Instructions to Bidders and General Conditions, Scope of Work and Special Conditions, Bid Form, and Addenda, if any, Notice of Award and Contract.

"Notice" means notice published requesting bids.

"Days" means calendar days unless otherwise specified.

- 2. CANVASS OF BID.** County Connection reserves the right to postpone bid openings for its own convenience. At the hour specified in the Notice to Bidders, or by County Connection upon postponement of the time originally set for bid opening, County Connection, in open session, will open, examine, read and publicly declare all bids received. Bidders, their representatives, and others interested, are invited to be present at the opening of bids.

The lowest responsive responsible bidder will be determined by the total price listed in Item I of the Bid Form. Sales taxes included in the total price must be separately stated.

- 3. SCOPE OF WORK.** It is the intent of County Connection to have the Contractor furnish the necessary labor and materials to install the two (2) 25,000 gallon above ground diesel fuel storage tanks at the Fuel Island per the technical specifications of this bid package and the Contractor's bid.
- 4. PRE-BID MEETING AND JOB WALK.** A pre-bid meeting will be conducted on March 9, 2026, at 10:00 a.m. at the County Connection Maintenance Building located at 2477 Arnold Industrial Way, Concord, CA 94520. This will be followed by a job walk on the same day to physically inspect the jobsite and further clarify the Scope of Work. All bidders are strongly encouraged to attend this meeting.

5. REQUESTS FOR APPROVED EQUALS, MODIFICATIONS OR CLARIFICATIONS.

- A. Request for Interpretation or Correction. Prospective bidders must examine the Contract Documents carefully. It shall be the duty of every person contemplating submitting a bid for the proposed contract, to submit to County Connection a request in writing, before bidding, for an interpretation or correction of every discrepancy, ambiguity, error or omission in any of the Contract Documents which should have been discovered by a reasonably prudent bidder.

Any interpretation, change or correction of said Contract Documents will be made by posted on County Connection's website at: countyconnection.com. Copies of such addenda will be mailed or delivered upon request only. Such addendum will become a part of the Contract Documents, and binding on all bidders whether or not actual notices of such addenda are shown.

- B. Requests for Approved Equals. It is understood that specifying a brand name, or specific types of components and/or equipment in these specifications shall not relieve the bidder from its responsibility to furnish the end product in accordance with the warranty and contractual requirements. The bidder is responsible for notifying County Connection of any inappropriate brand names, or types of components and/or equipment that may be called for in these specifications, and to propose a suitable substitute for consideration. Unless otherwise specifically provided in the specifications, reference to any equipment, material, article or patented process by trade name, make or catalog number shall be regarded as establishing a standard of quality and shall not be construed as limiting competition.

A bidder may, at its option, use any equipment, material, article, or process, which, in the judgment of County Connection, is equal to that designated. To do so a bidder shall furnish at its own expense, all test results, technical data and background information required by County Connection in making the determination as to whether the proposed equipment, material, article or process, in the judgment of County Connection, is equal to that designated.

County Connection shall be the sole judge as to the comparative quality and suitability of alternative equipment, articles, material or process, and its decision shall be final.

- C. Approved Equal Procedures.
- a. Requests for Approved Equals must be received by County Connection on the form provided, in writing, no later than March 16, 2026, 5:00 p.m. No such requests will be considered by County Connection if received after this date. Any request for an Approved Equal must be fully supported with technical data, test results or other pertinent information as evidence that the substitute offered is equal to or better than the specification requirement. In addition, any test requirements in the specifications that pertain to an item under consideration for Approved Equal must be submitted with the request for Approved Equal. All Requests for Approved Equals shall be emailed to County Connection's Chief Financial Officer, Amber Johnson, at ajohnson@cccta.org, or County Connection's Facility Superintendent, Steve Muhlestein, at muhlestein@cccta.org.
- b. County Connection's reply to requests received pursuant to Paragraph a. above, will be posted on countyconnection.com by March 23, 2026. Failure to respond by that date shall be deemed to be a denial of the request. County Connection reserves the right to postpone bid opening for its own convenience.

D. Interpretations or Corrections Binding. Only the written interpretation or correction by addenda by County Connection shall be binding. Any oral modifications of the Contract Documents are void and ineffective.

6. **BRAND NAMES.** To establish a basis for quality, certain materials, processes, types of machinery and equipment, or kinds of materials may be specified in the Bid Documents, either by description of process or by designating a manufacturer by name and referring to its brand or product designation, or by specifying a kind of material. Wherever such names appear, the term "or approved equal" is considered to follow. It is not the intent of these Bid Documents to exclude other processes, equipment or materials of equal value, utility or merit provided they are approved, in writing, by County Connection.

Specifying a brand name, materials, components and/or equipment in the specifications shall not relieve the bidder from its responsibility to produce the product in accordance with the contractual requirements. The bidder is responsible for notifying County Connection of any inappropriate brand names, materials, components or equipment that may be called for in the specifications and to propose a suitable substitute. Nothing in this section shall limit or restrict the provisions regarding the warranty of fitness set forth in the Contract Documents.

7. **SPECIFICATIONS.** Prime Contractors and subcontractors may make appointments to discuss the specifications and inspect the work site. Changes to the specifications will be made only by written addendum executed by the Manager of Grants and Purchasing. In no event shall oral modifications be binding upon County Connection.

No advantage shall be taken by the bidder in the omission of any parts or details which go to make the services, materials, supplies and/or equipment to be procured complete and ready for service, even though such parts or details are not mentioned in the specifications. All units for parts not herein specified shall be the manufacturer's standard units.

8. **BIDDING PROCEDURES.** The following shall apply:

- A. All bids shall remain firm for sixty (60) days from presentation to the Board of Directors.
- B. County Connection reserves the right to postpone bid opening for its own convenience and to reject any and all bids.
- C. Changes to the specifications will be made by written addendum and posted at countyconnection.com executed by the Manager of Grants and Purchasing. Oral modifications are not binding on County Connection.
- D. Requests for clarifications of specifications and protest of specifications must be received by County Connection, in writing, not less than fifteen (15) full days before the date of scheduled bid opening. Any protest of the specifications must be fully supported with technical data, test results, or other pertinent information as evidence in support of the specification protest.
- E. County Connection's replies to requests will be posted at least five (5) full days before the date scheduled for bid opening at countyconnection.com.
- F. It should be understood that specifying a brand name, components and/or equipment in this specification shall not relieve the supplier from its responsibility to produce the product in accordance with the performance warranty and contractual requirements. The supplier is responsible for notifying County Connection of any inappropriate brand names, component and/or equipment that may be called for in the specifications and to propose a suitable substitute for consideration.

G. Conditional bids, or those which take exception to the specifications, will be considered non-responsive and **will** be rejected.

H. Bids must be submitted on the form provided. Bids submitted in any other form will be considered non-responsive and **will** be rejected.

9. **BID FORM AND SIGNATURE.** The bid shall be made on the form provided therefore and shall be enclosed in a sealed envelope marked and addressed as required. If the bid is made by a sole owner, it shall be signed with his/her full name and his/her address shall be given. If it is made by a partnership, it shall be signed with the partnership name by a member of the firm who shall also sign his/her own name and the name and address of each member shall be given. If the bidder is a corporation, two corporate officers must sign on behalf of the corporation as follows:

(1) one signature must be that of the chairman of the board, president or vice-president; and (2) the second signature must be that of the secretary, assistant secretary, chief financial officer or assistant treasurer. Alternatively, this bid may be executed by a single officer or a person other than an officer provided that evidence satisfactory to County Connection is provided demonstrating that such individual is authorized to bind a corporation (e.g., a copy of a certified resolution from the corporation's board or a copy of the corporation's by-laws). If the bid is made by a joint venture, it shall be signed on behalf of each participating company by officers or other individuals who have full and proper authority to do so. Bids submitted in any other form will be considered non-responsive and **will** be rejected.

10. **BID.** Blank spaces in the bid shall be properly filled. The phraseology of the bid must not be changed, and no additions shall be made to the items mentioned therein. Alterations by erasure or interlineations must be explained or noted in the bid over the signature of the bidder. If the unit price and the total amount named by a bid for any item do not agree, the unit price alone will be considered as representing the bidder's intention. Bids must be submitted on the form provided. Bids submitted in any other form will be considered non-responsive and **will** be rejected.

Subject to County Connection's obligations pursuant to the California Public Records Act (PRA), such information identified by Bidder as proprietary will not be disclosed. If the Bidder believes any bid, communication, or other document contains trade secrets or other proprietary information that the Bidder believes would cause substantial injury to the Bidder's competitive position if disclosed, the Bidder shall request that County Connection withhold from disclosure the proprietary information by marking each page containing such proprietary information as confidential. The Bidder must also submit a redacted copy of its bid and a confidentiality index explaining why the information is not subject to disclosure under the PRA. The Bidder may not designate its entire proposal or bid as confidential. Additionally, Bidder may not designate its cost proposal or any required bid forms or certifications as confidential. If Bidder requests that County Connection withhold from disclosure information identified as confidential, and County Connection complies with the Bidder's request, Bidder shall assume all responsibility for any challenges resulting from the non-disclosure, indemnify and hold harmless County Connection from and against all damages (including but not limited to attorney's fees that may be awarded to the party requesting the Bidder information), and pay any and all costs and expenses related to the withholding Bidder information.

11. **BIDDER'S SECURITY. Bidder's Security shall be submitted with bids in an amount specified in the Bidder's Security. The following forms are acceptable:**

A. An unconditional Certified or Cashier's Check on a solvent bank, payable to the order of Central Contra Costa Transit Authority; or

B. A Bidder's Bond, using the form entitled "Bidder's Bond," provided with the bid documents, and properly executed and acknowledged by the bidder and by an admitted

corporate surety authorized and admitted to transact such business in the State of California and acceptable to County Connection.

- C. An Irrevocable Standby Letter of Credit, which is available upon bidder's demand when accompanied by a signed statement from an Officer of County Connection, stating that the amount drafted is due to County Connection because of failure to enter into a written contract awarded to it by County Connection, or to furnish the requisite bond(s) or insurance certificates within the time and in the manner required by the Contract Documents and Specifications. This letter of credit is subject to the Uniform Customs and Practice for Documentary Credits (1993 Revision) of the International Chamber of Commerce Publication No. 500.

Any condition or limitation placed upon said check or any alteration of said form of bond, or imperfection in the execution thereof, as herein required, will render it informal and may at the option of County Connection, result in the rejection of the bid under which such check or bond is submitted. Said check or bidder's bond shall be a guarantee that the bidder will not withdraw its bid or, if awarded the contract, will execute the required contract and bonds within fifteen (15) days after such contract has been awarded to it or such additional time as may be allowed by County Connection. If the bidder withdraws its bid or fails or refuses to execute the required contract and bonds within said time, the money and proceeds from the check or bond, as the case may be, shall be applied towards payment of the damage to County Connection on account of the delay in the execution of the contract and bonds and the performance of the work thereunder, and the necessity of accepting a higher or less desirable proposal, resulting from such failure or refusal to execute the contract and bonds as required. The amount of the check or bond, as the case may be, shall not constitute a limitation upon the right of County Connection to recover for the full amount of such damage. The check or bond of the successful bidder and the next two highest bidders will be returned after the execution of the contract with the successful bidder and the approval of its bonds by County Connection. The checks or bonds of all other bidders will be returned promptly after the bids have been opened and reviewed by County Connection.

12. **CONDITIONED BID.** Unauthorized conditions, limitations or provisions attached to a bid will render the bid non-responsive and may cause its rejection. No telegraphic bids or modifications will be considered.
13. **ALTERNATIVE BID.** Submission of alternative bid, except as specifically called for in the specifications or bid forms, will render the bids non-responsive and will cause their rejection.
14. **SUBMISSION OF BID.** Prior to the hour specified in the notice inviting sealed bids, all bids shall be delivered to the Chief Financial Officer at the address shown in the Notice to Bidders. All bids shall be in a sealed envelope properly endorsed as to "Installation of Above Ground Diesel Fuel Storage Tanks", project number, and opening date. Bids received after said time or at any place other than the time and place stated in the notice will not be considered.
15. **WITHDRAWAL OF BID.** A bidder may withdraw its bid before the expiration of the time during which bids may be submitted, without prejudice to itself, by submitting a written request for its withdrawal to the officer who holds the bid.
16. **FIRM BID.** All bids shall remain in effect for sixty (60) days from presentation of bid to the Board of Directors of County Connection.
17. **TAXES.** The supplies, materials or equipment called for under the specifications will be used by County Connection in the performance of a governmental function and are exempt from taxation by the United States Government. County Connection will, if requested, furnish a tax exemption certificate and any and all affidavits and documents that may be necessary to establish such exemption. State sales or use tax shall be included in the bid price.

- 18. INSPECTION BY BIDDER AND WAIVER.** The bidder represents and warrants that it has sufficiently informed itself in all matters affecting the performance of the work or the furnishing of the labor, supplies, material or equipment called for in the Contract Documents; that it has checked its bid for errors and omissions; that the prices stated in its bid are correct and as intended by it and are a complete and correct statement of its prices for performing the work or furnishing the labor, supplies, materials or equipment required by the Contract Documents. The bidder waives any claim for the return of its bid deposit if on account of errors or omissions claimed to have been made by it in its bid, or for any other reason, it should refuse or fail to execute the contract.
- 19. REJECTION OF BID.** County Connection may reject any and all bids and will reject a bid of any party who has been delinquent or unfaithful in any former contract with County Connection. The right is reserved to reject any or all bids, and to waive technical defects, as the interests of County Connection may require. County Connection may reject bids from bidders who cannot satisfactorily prove the experience and qualifications outlined in Paragraph 22 of the Instructions to Bidders and General Conditions.
- 20. BASIS OF AWARD, EXECUTION AND DELIVERY.**
- A. The contract, if awarded by County Connection, will be awarded to the lowest responsive and responsible whose bid complies with the requirements prescribed, based upon a comparison of the total cost shown on the Bid Form (TOTAL PRICE).
 - B. Sole Bid.
 - i. In the event a single bid is received, County Connection may conduct a price and/or cost analysis of the bid. A price analysis is the process of examining the bid and evaluating a prospective price without evaluating the separate cost elements. It should be recognized that a price analysis through comparison to other similar procurements must be based on an established or competitive price of the elements used in the comparison. The comparison must be made to a purchase of similar quantity and involving similar specifications. Where a difference exists, a detailed analysis must be made of this difference and costs attached hereto.
 - ii. Where it is impossible to obtain a valid price analysis, it may be necessary for County Connection to conduct a cost analysis of the bid price.
 - iii. The price and/or cost analysis shall be made by competent and experienced auditors or price analysts. An engineer's estimate or comparison of the prices involved is insufficient.
 - C. Award of Contract. County Connection will make the award or rejection within sixty (60) days after submission of the bids and will transmit contract documents within a reasonable time thereafter.
 - D. Execution of Agreement. The form of Agreement that the successful bidder, as Contractor, will be required to execute and the bonds and certificates of insurance coverage that are required shall be provided within fifteen (15) days after the award of the bid. All bonds and policies or certificates of insurance shall be approved by the General Manager before the successful bidder may proceed with the work. Failure or refusal to furnish bonds or insurance policies or certificates in the form satisfactory to the General Manager shall be just cause for the annulment of the award and the forfeiture of the bidder's security.

- E. Final Approved Specifications. The final approved specifications must be adhered to by all bidders.

Contract Commencement Date. The contract commencement date shall be the date of "authorization to proceed." "Authorization to proceed" shall be issued the day after insurance certificates and bonds are received by County Connection. Notification of award and "authorization to proceed" shall be made to the successful bidder in writing by County Connection.

21. PROTEST PROCEDURES.

A. Specifications Protest

- i. Submission of Protest; Initial Procedures. Protests based upon alleged restrictive specifications, improprieties in the bidding procedure or contract specifications, which are apparent or reasonably should have been discovered prior to bid opening, shall be filed by the bidder and received in writing by County Connection not later than five (5) working days before bid opening. The protest must clearly specify in writing the grounds and evidence on which the protest is based. If the protestor later raises new grounds or new evidence not previously set forth in written submissions to County Connection that reasonably could have been raised, County Connection will not consider such new grounds or evidence in the determination on the protest. Where the determination could affect bid responses, an appropriate extension of the bid opening date may be granted. The protest will be considered in the manner described below.
- ii. Notice of When Protest Will be Considered; Appropriate Reviewing Party. A protest based upon alleged improprieties that are apparent or which reasonably should have been discovered prior to bid opening will not be considered by the General Manager unless the protestor has submitted its protest to County Connection in accordance with Subsection i, above.
- iii. Reviewing Party. A protest based upon specifications or alleged improprieties in the bidding procedure will be reviewed by the General Manager. Upon the submission of a protest to County Connection, the initiating Department will advise the protestor and all other bidders for the subject contract, in writing, that the General Manager will consider the protest. The General Manager shall consider the protest on the basis of the written protest and upon recommendation of staff and Legal Counsel and shall issue a final written decision. The General Manager's decision shall be final.

B. Award Protest

- i. Submission of Protest; Initial Procedures. Protests based upon alleged improprieties that are not apparent or which could not reasonably have been discovered prior to bid opening, such as disputes over the staff recommendation for contract award, shall be submitted in writing to County Connection within forty-eight (48) hours from receipt of the notice from County Connection advising of the staff's recommendation for award of contract.
- ii. The protest must clearly specify in writing the grounds and evidence on which the protest is based. If the protestor later raises new grounds or new evidence not previously set forth in written submissions that reasonably could have been raised, County Connection will not consider such new grounds or evidence in the

determination on the protest. Staff shall analyze the protest and develop a recommendation. The protest will be considered in the manner described below.

- iii. Notice of When Protest Will be Considered; Appropriate Reviewing Party. A protest based upon the award of the contract will not be considered by the appropriate reviewing party unless the protestor has submitted its protest to staff in accordance with subsection i, above.
 - a. Contracts valued up to and including \$100,000. Protests involving a contract valued up to and including \$100,000 will be reviewed by the General Manager. Upon the submission of a protest to County Connection, the initiating Department will advise the protestor and all other bidders for the subject contract, in writing, that the General Manager will consider the protest. The General Manager shall consider the protest on the basis of the written protest and upon recommendation of staff and Legal Counsel and shall issue a final written decision. The General Manager's decision shall be final.

FAILURE TO COMPLY WITH THE RULES SET FORTH HEREIN MAY RESULT IN REJECTION OF THE PROTEST.

22. **STATEMENT OF EXPERIENCE AND QUALIFICATIONS.** The bidder may be required, upon request of the General Manager, to prove to the General Manager's satisfaction that the bidder has the skill and experience and that it has the necessary facilities and ample financial resources to perform the contract in a satisfactory manner and within the required time.

In addition, to be deemed a responsive bidder, the bidder must have adequate engineering and service personnel and facilities to satisfy any engineering or service problem which may arise during the warranty period.

23. **NON-COLLUSION DECLARATION.** By submitting a bid, the bidder represents and warrants that such bid is genuine and not sham or collusive or made in the interest or in behalf of any person not therein named, and that the bidder has not, directly or indirectly, induced or solicited any other bidder to put in a sham bid, or any other person, firm or corporation to refrain from proposing, and that the bidder has not in any manner sought by collusion to secure to the bidder an advantage over any other bidder. The Non-Collusion Declaration form found with the Bid Form shall be completed and returned with the Bid package.
24. **PENALTY FOR COLLUSION.** If at any time it shall be found that the person, firm or corporation to whom a contract has been awarded has, in presenting any bid or bids, colluded with any other parties, then the contract so awarded shall be null and void; and the Contractor and its bondsmen shall be liable to County Connection for all loss or damage which County Connection may suffer thereby; and the Board of Directors may advertise for a new contract for said labor, supplies, materials or equipment.
25. **PROHIBITED INTEREST.** By submitting a bid, Contractor represents that to the best of its knowledge, no Board Member, officer, or employee of County Connection has any interest, contractual or non-contractual, financial or otherwise, in this transaction or in the business of Contractor. And if any such interest comes to the knowledge of Contractor at any time, a full and complete disclosure of all such information shall be made in writing to County Connection, even if such interest would not be considered a conflict of interest under Article IV Division 4 (commencing with Section 1090) or Division 4.5 (commencing with Section 3600) of the Government Code of the State of California. No member, officer, or employee of County Connection or of any of its member jurisdictions during his/her tenure of office, or for one year thereafter, shall have any interest, direct or indirect, in this contract or the proceeds there from.

26. **INTEREST OF COUNTY CONNECTION PERSONNEL.** By submitting a bid, the bidder represents and warrants that neither the General Manager, nor any Director, officer, agent or employee of County Connection, is in any manner interested directly or indirectly in the bid or in the contract which may be made under it, or in any expected profits to arise there from, as set forth in Article 4, Division 4, Title 1 (commencing with Section 1090) of the Government Code of the State of California.

27. **TIME FOR EXECUTION OF CONTRACT AND FILING PERFORMANCE AND PAYMENT BONDS.** The bidder to whom award is made shall execute the written contract with County Connection, on the form of contract of County Connection, submit the required Insurance Certificates, and furnish a good and approved performance and payment bonds as herein required within fifteen (15) days after receiving the forms of contract and bonds for execution. If the bidder to whom award is made fails to enter into the contract as herein provided and to furnish said performance and payment bonds or insurance certificates, the award will be annulled, and an award may, in the discretion of the Board, be made to the bidder whose bid is next most acceptable in the opinion of the Board of Directors of County Connection; and such bidder shall fulfill every stipulation embraced herein as if it were the party to whom the first award was made.

28. **EXECUTION OF CONTRACT, MANNER OF.** If the Contractor is an individual, the Contract shall be executed by him/her personally. If the Contractor is a partnership, it is desirable that the Contract be executed by all of the partners, but it must be executed by at least one of them. Alternatively, this bid may be executed by a single officer or a person other than an officer provided that evidence satisfactory to County Connection is provided demonstrating that such individual is authorized to bind a corporation (e.g., a copy of a certified resolution from the corporation's board or a copy of the corporation's by-laws.). If the Contractor is a joint venture, the Contract must be executed on behalf of each participating firm by officers or other individuals who have the full and proper authorization so to do.

29. **PAYMENT AND PERFORMANCE BONDS.** The bidder to whom the Contract is awarded shall furnish the following bonds ("Contract Bonds"):

- A. Performance Bond, in an amount not less than one hundred percent (100%) of the Contract price, to secure faithful performance of the Contract and the guarantees against defective workmanship, materials, or both during the warranty period following final acceptance of the work by the County Connection.
- B. For contracts over \$25,000, a Payment Bond, in an amount not less than one hundred percent (100%) of the Contract price to secure payment of all persons supplying labor and materials for the construction of the work.

Contract bonds shall be on the forms contained in the Bid Documents and shall be executed as surety by a corporation authorized to issue surety bonds in the State of California, with a financial condition and record of service satisfactory to County Connection.

All alterations, extensions of time, extra and additional work, and other changes authorized by the Contract Documents may be made without securing the consent of the surety or sureties on the Contract Bonds.

30. **ADDITIONAL SURETIES.** If at any time during the continuance of the contract, the sureties, or any of them, shall, in the opinion of County Connection become irresponsible, County Connection shall have the right to require additional and sufficient sureties which Contractor shall furnish to the satisfaction of County Connection within ten (10) days after notice.

- 31. CHANGES OF CONTRACT BY CONTRACTOR.** If the Contractor, on account of conditions developing during the performance of the contract, finds it impracticable to comply strictly with the specifications and applies in writing for a modification of requirements, such change may be authorized only in writing by the General Manager, if not detrimental to County Connection and if without additional cost to County Connection. Any additional material costs required pursuant to the scope of work shall be paid to the Contractor as agreed by the parties.
- 32. CHANGES OF CONTRACT BY COUNTY CONNECTION.** In case any work, materials or equipment shall be required which are not mentioned, specified or indicated, or otherwise provided for herein, the Contractor shall, if ordered in writing by the Manager of Grants and Purchasing, do and perform such work and furnish such materials or equipment, at a price agreed to by the parties.
- 33. DOCUMENTS INCORPORATED AS PART OF CONTRACT.** The Notice, Invitation to Bidders, Instructions to Bidders and General Conditions, Bid, Technical Specifications, Special Conditions (if any) and Addenda, if any, will be incorporated as part of the contract.
- 34. STATEMENT OF FINANCIAL ASSISTANCE.** This contract may be based on a financial assistance contract between County Connection and may be subject to the laws and regulations governing use of such funds. In such event, Contractor shall familiarize itself with such laws and regulations and comply therewith.
- 35. DELIVERY.**
- A. The two (2) 25,000 gallon above ground diesel fuel storage tanks and related materials needing installation will be delivered to County Connection's facility in Concord at Building at 2477 Arnold Industrial Way Concord, CA 94520, by April 8, 2026. Contractor shall assume all responsibility and risk of loss incident to said work until acceptance by County Connection.
 - B. In case the delivery of material under this contract shall be necessarily delayed because of strike, injunctions, government controls, or by reason of any other cause of circumstances beyond the control of the contractor, the time of completion shall be extended by a number of days to be determined in each instance by mutual agreement between the successful bidder and County Connection.
 - C. Work shall commence within thirty (30) calendar days following the receipt date on the Notice to Proceed and completed within sixty (60) calendar days from commencement of work.
 - D. Acceptance by County Connection shall be understood to occur only subsequent to final quality control inspection by responsible assigned employees of County Connection. County Connection will notify the Contractor, in writing, within fifteen (15) days after completion of the installation whether it has or has not been accepted. A letter of non-acceptance will furnish details of defects, deficiencies and damage.
- 36. EXTENSIONS OF TIME.** Granting of or acceptance of extensions of time to complete the performance by the Contractor will not operate as a release to Contractor or otherwise modify the terms and conditions of the contract.
- 37. FAILURE TO COMPLETE CONTRACT.** In case of failure on the part of the Contractor to complete its contract within the specified time or within an authorized extension thereof and the contract may be terminated, and County Connection shall, in such event, not thereafter pay or allow to contractor any further compensation for any labor, supplies or materials furnished by it under said contract; and the Board may proceed to complete such contract either by re-letting or

otherwise and Contractor and its sureties shall be liable to County Connection for all loss or damage which it may suffer on account of Contractor's failure to complete its contract within such time.

38. TERMINATION.

- A. County Connection may, subject to the following provisions, by written notice of default to Contractor, terminate the whole or any part of this contract in any one of the following circumstances:
 - i. If Contractor fails to deliver and/or install materials and equipment or to perform services as provided for herein within the time specified herein or any extension thereof; or
 - ii. If Contractor fails to perform any of the other provisions of the Contract, or so fails to make progress as to endanger performance of the Contract, in accordance with its terms and, in either of these two circumstances, does not rectify such failure within a period of ten (10) days (or such other period as County Connection may authorize in writing) after receipt of written notice from County Connection specifying such failures.
- B. County Connection may also terminate the contract at any time by giving the Contractor thirty (30) days' notice thereof.
- C. Notice of termination shall be given by certified mail or personal service to the Contractor at the address specified in the Contract Documents as amended in writing.
- D. If County Connection terminates the contract in whole or in part, as provided in subparagraph (A) above, County Connection may procure materials and equipment and contract for services similar to those so terminated; and Contractor shall be liable to County Connection for any excess costs for such similar materials and equipment and services.
- E. Upon termination, Contractor shall submit a written closing statement to County Connection to specify the costs of materials and equipment delivered to County Connection and installed, and the costs of services actually performed to the date of termination for which Contractor has not been previously paid.
- F. County Connection may deduct any excess costs incurred under subparagraph (D) above, and any liquidated damages under Paragraph 41 of the Instructions to Bidders and General Conditions, from the amount set forth in the Contractor's closing statement. Upon payment of the amount found due, County Connection shall be under no further obligation, financial or otherwise to Contractor except, and only to the extent of, any obligations imposed by Contractor's continued performance under subparagraph (G) below.
- G. The Contractor shall continue the performance of the contract to the extent not terminated under the provisions of this clause.
- H. Contractor shall not be liable for excess costs if acceptable evidence has been submitted to County Connection that failure to perform the Contract giving rise to such costs was due to causes beyond the control and without the fault or negligence of the Contractor.

39. PAYMENTS. One hundred percent (100%) of the contract price for the complete work furnished under these specifications will be paid to the Contractor within sixty (60) days after

delivery to and issuance of final acceptance by County Connection as herein provided and after the final invoice covering the specified work has been presented to County Connection by Contractor. No progress payments will be considered on this project.

40. **WAIVER.** The waiver by any party of a breach of this contract shall not constitute a continuing waiver or a waiver of any subsequent breach, either of the same or different provision of this contract.
41. **LIQUIDATED DAMAGES.** In the event of delay in completion of the work or the delivery of the supplies, materials or equipment beyond the date set forth in the Contract Documents, or beyond authorized extensions thereof, damage will be sustained by County Connection. It is and will be impracticable to determine the actual amount of damage by reason of such delay. It is, therefore, agreed that County Connection shall be paid liquidated damages in the amount of \$500.00 for each and every day that the completion extends beyond the delivery date. If the delay in delivery is caused by strikes, government controls, or other causes beyond the control of Contractor, an extension of time without liquidated damage liability shall be granted by County Connection upon a proper showing and finding by County Connection that the extension is justified. Contractor shall have the burden of showing that the delay was beyond its control. The findings by County Connection shall be final and conclusive.
42. **DEFECTIVE OR DAMAGED WORK.** Any work, material, equipment or supplies found to be damaged or defective at the time of delivery shall be repaired, replaced or corrected by the Contractor without additional cost to County Connection.

If the Contractor shall fail to comply promptly with any order of the General Manager to repair, replace or correct damaged or defective work, then the General Manager shall, upon written notice to the Contractor, have the authority to deduct the cost thereof from any compensation due or to become due the Contractor.

Nothing in this section shall limit or restrict the provisions of the warranty of fitness as set forth in these Instructions to Bidders and General Conditions.

43. **ASSIGNMENT.** The contract may not be assigned, transferred, conveyed, sublet or otherwise disposed of without prior consent in writing of the General Manager and the Contractor.
44. **COMPLIANCE WITH LAWS AND REGULATIONS.** All materials and supplies furnished pursuant to these specifications shall comply with the laws and regulations of the State of California and the United States of America. Contractor shall, if requested by County Connection, supply certification and evidence of such compliance.
45. **LAW OF CALIFORNIA.** The contract hereunder shall be governed by the laws of the State of California.
46. **WARRANTY OF TITLE.** Contractor warrants to County Connection, its successors and assigns that the title to the materials, supplies or equipment covered by the contract, when delivered to County Connection or to its successors or assigns, is free from all liens and encumbrances.
47. **WARRANTY OF FITNESS.** Contractor warrants that all materials, supplies and products furnished meet the requirements and conditions of the Contract Documents and are fit for the purpose intended.
48. **WARRANTY OF MERCHANTABILITY.** Contractor warrants that the goods are merchantable in accordance with Section 2314 of the Commercial Code of the State of California.

In accepting this and other warranties and the materials or supplies to be manufactured or assembled pursuant to the Contract Documents, County Connection does not waive any warranty, either express or implied, in Sections 2312 to 2315, inclusive, of the Commercial Code of the State of California or any liability of the manufacturer as determined by any decision of a court of the State of California or of the United States.

49. WARRANTY OF PRODUCT.

- A. The Contractor warrants each material or equipment supplied, including all equipment and accessories installed thereon by the Contractor to be free from defects in design, material and workmanship for a period of three (3) years after completion of the work is accepted by County Connection.
- B. In the event that during the warranty period repairs, modifications, or both, on said building are made necessary by defective installation by the contractor, and the Contractor's inability to provide the proper repair, the delay extending beyond the end of the warranty period, such delay shall not be considered in computing the warranty period, and the same warranty will remain in effect as if the repair or modification was still within the warranty period, said warranty being extended by the period of delay.
- C. Nothing in these requirements, conditions, or specifications, including County Connection's right to a complete inspection, shall constitute a disclaimer to or limit, negate, exclude or modify in any way any warranty provided hereunder.
- D. Should any item of material or equipment become inoperable or broken in normal use or exhibit leakage of any kind within the three (3) year warranty period, the item of material or equipment will be considered defective and shall be repaired or replaced at no cost to County Connection. While the defective item of material or equipment is in the possession of the Contractor for repair, the Contractor shall furnish a substitute item of material or equipment for County Connection's use. Repair costs and replacement costs for the purpose of this warranty provision shall include freight or postage costs.

50. CONTRACTOR'S INDEMNITY. The Contractor shall defend, indemnify, and save harmless County Connection and its directors, members, agents, officers, and employees (collectively "Indemnitees") from any and all claims, demands, causes of action, damages, costs, suits, regulatory fines, or other actions of every name, kind and description (collectively "Claims") brought for, or on account of, injuries to or death of any person (including but not limited to employees of Contractor and its subcontractors); or damage to property; or economic damage from any cause whatsoever arising out of, connected to, or in any way related to the Contractor's work (including the work of its subcontractors) or performance of this Contract, including any breach of any provision of this Contract, except to the extent that such Claims were caused by the active negligence of County Connection or other Indemnitee or such indemnification is otherwise prohibited under applicable law. The Contractor shall, at its own expense, defend such actions and shall pay all reasonable attorney's fees and costs incurred (as they are incurred) in connection therewith, and if any judgment shall be rendered against County Connection in any such action, the Contractor shall, at its own expense, satisfy and discharge the same; however, the Contractor shall not be held responsible for loss, damage, liability, injury or death occasioned by the negligent act(s) or willful misconduct of County Connection, its agents or employees. This indemnification shall extend to Claims arising after the work is completed and accepted. No inspection by County Connection of Contractor's work shall be deemed a waiver by County Connection of full compliance with the requirements of this section by the Contractor.

51. RISK OF LOSS. All loss or damage arising from any unforeseen obstruction or difficulties, either natural or artificial, which may be encountered in the execution of the work, or the furnishing of the supplies, materials, or equipment, or from any action of the elements prior to

final written acceptance of the work, or of the supplies, materials or equipment, or from any act or omission not authorized by the Contract Documents on the part of the Contractor or any agent or person employed by it, shall be sustained and borne solely by the Contractor.

- 52. RECORDS.** Contractor shall maintain full and adequate books, records and accounts to show the actual time devoted and costs incurred by it with respect to performance of services under this agreement; provided that said books, records and accounts shall be kept in accordance with generally accepted accounting principles.
- 53. SUBCONTRACTS.** Contractor shall not subcontract all or any portion of its services under this agreement without the prior written approval of the Manager of Grants and Purchasing, and any attempt thereat shall be void and unenforceable. In the event the Contractor enters into one or more subcontracts pursuant to this paragraph, it is understood and agreed that the participating subcontractors shall be solely and directly responsible to Contractor and that County Connection shall have no obligation to them.
- 54. AUDIT.** Contractor shall permit County Connection and its authorized representatives and regional, state, and Federal grantors and their authorized representatives to inspect and examine Contractor's books, records, accounts, and any and all data relevant to this agreement at any reasonable time for the purpose of auditing and verifying statements, invoices, or bills submitted by Contractor pursuant to this agreement and shall provide such assistance as may be reasonably required in the course of such inspection. County Connection further reserves the right to examine and re-examine said books, records, accounts, and data during the three (3) year period following the termination of this agreement; and Contractor shall in no event dispose of, destroy, alter, or mutilate said books, records, accounts, and data in any manner whatever for three (3) years after the termination of this agreement or after all other pending matters concerning this agreement, if any, are closed, whichever occurs later.
- 55. DISADVANTAGED BUSINESS ENTERPRISES.**

On October 3, 2025, the U.S. Department of Transportation (DOT) issued an Interim Final Rule amending Title 49, Code of Federal Regulations, Part 26, Participation by Disadvantaged Business Enterprises in DOT Financial Assistance Programs (Interim Final Rule). As a result of the Interim Final Rule, County Connection has placed a moratorium on some of the DBE requirements associated with this IFB. That moratorium may be lifted if the Interim Final Rule is not made permanent, or is otherwise amended. As a result of the Interim Final Rule, the DBE certification standards have changed, and the DBE database maintained by the California Unified Certification Program (CUCP) lists DBE firms certified under invalid certification standards. As of the issuance date of this IFB, Bidders are not required to obtain DBE participation on this contract and County Connection may not count DBE participation on this contract towards its overall DBE goal. County Connection may, at some time in the future, direct the Contractor to maintain records of all DBE participation in the performance of this contract. In the event that County Connection directs the Contractor to maintain records of DBE participation in the performance of this contract, all DBE firms participating in the project must be certified DBEs as of the date of such direction by County Connection. County Connection will accept certifications by the CUCP that are in compliance with the Interim Final Rule. County Connection, as a recipient of federal financial assistance from the Federal Transit Administration (FTA), is committed to and has adopted a DBE Program in accordance with federal Regulations 49 CFR Part 26 issued by the U.S. Department of Transportation (DOT).

It is County Connection's policy to ensure nondiscrimination in the award and administration of all contracts and to create a level playing field on which Disadvantaged Business Enterprises (DBEs) can compete fairly for contracts and subcontracts relating to County Connection's construction, procurement and professional services activities. To this end, County Connection has developed procedures to remove barriers to DBE participation in the bid and award process

and to assist DBEs to develop and compete successfully outside of the DBE Program. In connection with the performance of this contract, the Contractor will cooperate with County Connection in meeting these commitments and objectives.

Pursuant to U.S. DOT Regulations 49 CFR Part 26, the Contractor is required to make the following assurance in its agreement with County Connection and to include this assurance in any agreements it makes with subcontractors in the performance of this contract:

The Contractor (and any subcontractors) shall not discriminate on the basis of race, color, national origin or sex in the performance of this contract. The Contractor (and any subcontractors) shall carry out applicable requirements of the 49 CFR Part 26 in the award and administration of U.S. DOT-assisted contracts. Failure by the Contractor (and any subcontractors) to carry out these requirements is a material breach of this contract, which may result in the termination of this contract or such other remedy, as County Connection deems appropriate.

By submitting a bid, the Contractor is deemed to have made the foregoing assurance and to be bound by its terms.

In addition to and in accordance with the federal DBE Regulations (49 CFR Part 26.39), County Connection has implemented a small business element, as part of its DBE Program. County Connection encourages the participation of Disadvantaged Business Enterprises (DBEs) for contracting and subcontracting opportunities available at County Connection. Disadvantaged Business Enterprises (DBEs) are often eligible for certification as Small Business Enterprises (SBEs); therefore, County Connection also encourages the participation of certified SBEs, who meet the current SBA business size standard. County Connection will not accept certifications/verifications by agencies that allow companies to self-certify as small businesses. County Connection's DBE Officer is available to assist bidders with identifying subcontracting opportunities, and DBE and SBE resources.

A completed and signed List of Prime Contractor and Subcontractors/Suppliers form must be submitted with the bid. This form includes information about the Bidder and all subcontractors/suppliers that provided a bid, quote or proposal.

Where the successful Contractor has indicated that SBE firms will be utilized under this contract, Contractor shall submit to the DBE Officer periodic progress and participation reports documenting that SBE utilization. These reports shall be prepared and certified correct by the Contractor or its authorized representative. The SBE reporting forms to be used for this purpose will be furnished by the DBE Officer after award of contract.

The selected Contractor shall maintain records to verify applicable SBE participation. Such records shall show the name and business address of each SBE participating in the contract, the total dollar amount actually paid each SBE, and the date of payment. Contractor shall retain all records concerning DBE and SBE participation under this contract for not less than three years.

Contractor shall not make substitutions of previously approved SBE subcontractors or suppliers without prior written approval from County Connection.

County Connection reserves the right to request additional information regarding SBE participation in this Contract. Failure to submit the requested information and/or documentation within the times stated shall make the Bidder ineligible for award.

Any Bidder who would like additional information regarding participation on this contract or County Connection's DBE Program, may contact Kristina Martinez, DBE Officer, at 2477 Arnold Industrial Way, Concord, California 94520, (925) 680-2031.

56. EQUAL EMPLOYMENT OPPORTUNITY. In connection with the performance of this Contract, the Contractor shall not discriminate against any employee or applicant for employment because of race, color, religion, citizenship, political activity or affiliation, national origin, ancestry, physical or mental disability, marital status, age, medical condition (as defined under California law), veteran status, sexual orientation, gender identity, gender expression, sex or gender (which includes pregnancy, childbirth, breastfeeding, or related medical conditions), taking or requesting statutorily protected leave, or any other characteristics protected under federal, state, or local laws. The Contractor shall take affirmative actions to ensure that applicants are employed, and that employees are treated during their employment, without regard to their race, religion, color, sex, disability, national origin, or any other characteristic protected under state, federal, or local laws. Such actions shall include, but not be limited to, the following: employment, upgrading, demotion or transfer, recruitment or recruitment advertising, layoff or termination, rates of pay or other forms of compensation; and selection for training, including apprenticeship. The Contractor agrees to post in conspicuous places, available to employees and applicants for employment, notices to be provided by the contracting officer setting forth the provisions of this non-discrimination clause. The Contractor further agrees to insert a similar provision in all subcontracts, except subcontracts for standard commercial supplies or raw materials.

The Contractor will, in all solicitations or advancements for employees placed by or on behalf of the Contractor, state that all qualified applicants will receive consideration for employment without regard to race, color, religion, sex, sexual orientation, gender identity, or national origin.

The Contractor will not discharge or in any other manner discriminate against any employee or applicant for employment because such employee or applicant has inquired about, discussed, or disclosed the compensation of the employee or applicant or another employee or applicant. This provision shall not apply to instances in which an employee who has access to the compensation information of other employees or applicants as a part of such employee's essential job functions discloses the compensation of such other employees or applicants to individuals who do not otherwise have access to such information, unless such disclosure is in response to a formal complaint or charge, in furtherance of an investigation, proceeding, hearing, or action, including an investigation conducted by the employer, or is consistent with the Contractor's legal duty to furnish information

57. SAFETY AND HEALTH STANDARDS. It is the condition of this contract, and shall be made a condition of each subcontract entered into pursuant to this Contract, that the Contractor and any subcontractor shall not require any laborer or mechanic employed in the performance of the contract to work in conditions which are unsanitary, hazardous or dangerous to his/her health or safety, as determined under construction safety and health standards promulgated by the U.S. Secretary of Labor, in accordance with Section 107 of the Contract Work Hours and Safety Standards Act (83 Stat. 96).

58. CIVIL RIGHTS REQUIREMENTS. The following requirements apply to the underlying contract:

- (1) Nondiscrimination - In accordance with Title VI of the Civil Rights Act, as amended, 42 U.S.C. § 2000d, section 303 of the Age Discrimination Act of 1975, as amended, 42 U.S.C. § 6102, section 202 of the Americans with Disabilities Act of 1990, 42 U.S.C. § 12132, and Federal transit law at 49 U.S.C. § 5332, the Contractor agrees that it will not discriminate against any employee or applicant for employment because of race, color, religious creed, ancestry, national origin, age, sex, physical or mental disability, medical condition, marital status, veteran's status or sexual orientation. In addition, the Contractor agrees to comply with applicable Federal implementing regulations and other implementing requirements FTA may issue.

- (2) Equal Employment Opportunity - The following equal employment opportunity requirements apply to the underlying contract:
- (a) Race, Color, Creed, National Origin, Sex - In accordance with Title VII of the Civil Rights Act, as amended, 42 U.S.C. § 2000e, and Federal transit laws at 49 U.S.C. § 5332, the Contractor agrees to comply with all applicable equal employment opportunity requirements of U.S. Department of Labor (U.S. DOL) regulations, 42 U.S.C. § 2000e note), and with any applicable Federal statutes, executive orders, regulations, and Federal policies that may in the future affect construction activities undertaken in the course of the Project. The Contractor agrees to take affirmative action to ensure that applicants are employed, and that employees are treated during employment, without regard to their race, color, religious creed, ancestry, national origin, age, sex, physical or mental disability, medical condition, marital status, veteran's status or sexual orientation.. Such action shall include, but not be limited to, the following: employment, upgrading, demotion or transfer, recruitment or recruitment advertising, layoff or termination; rates of pay or other forms of compensation; and selection for training, including apprenticeship. In addition, the Contractor agrees to comply with any implementing requirements FTA may issue.
 - (b) Age - In accordance with section 4 of the Age Discrimination in Employment Act of 1967, as amended, 29 U.S.C. §§ 623 and Federal transit law at 49 U.S.C. § 5332, the Contractor agrees to refrain from discrimination against present and prospective employees for reason of age. In addition, the Contractor agrees to comply with any implementing requirements FTA may issue.
 - (c) Disabilities - In accordance with section 102 of the Americans with Disabilities Act, as amended, 42 U.S.C. § 12112, the Contractor agrees that it will comply with the requirements of U.S. Equal Employment Opportunity Commission, "Regulations to Implement the Equal Employment Provisions of the Americans with Disabilities Act," 29 CFR Part 1630, pertaining to employment of persons with disabilities. In addition, the Contractor agrees to comply with any implementing requirements FTA may issue.
- (3) The Contractor also agrees to include these requirements in each subcontract financed in whole or in part with Federal assistance provided by FTA, modified only if necessary to identify the affected parties.

- 59. QUALITY OF CONSTRUCTION.** All materials or parts not herein contained or specified shall be of the manufacturer's standard and shall conform in materials, design, or workmanship to the best practice known in the building trades. All parts shall be new and in no case will used, reconditioned, or obsolete parts be accepted.
- 60. RIGHT TO INSPECT.** County Connection representatives, upon approval by the Contractor, shall have the right and shall be at liberty to inspect, with the cooperation of the Contractor, the contractor's facility and workmanship during the performance process, and shall have the right to reject all materials and workmanship which do not conform with the specifications. County Connection is under no duty to make such inspection and whether such inspection is or is not made, the Contractor shall not be relieved of any obligation to furnish materials and workmanship strictly in accordance with specifications. All reports shall be submitted to the Contractor. Any inspection visit shall take place during normal business hours.

County Connection shall have full power to reject or condemn any materials furnished, or work performed, under the contract which does not conform to the terms and conditions set forth in the Contract Documents.

- 61. DISCREPANCIES.** Whenever in the Contract Documents an amount is stated in both words and figures, in case of discrepancy between words and figures, the words shall prevail; if all or any portion of the bid is required to be given in unit prices and totals so given, the unit prices shall prevail.
- 62. INDEPENDENT CONTRACTOR.** Contractor is an independent contractor and not an employee of County Connection and has no authority to contract or enter into any agreement in the name of County Connection. Contractor has, and hereby retains, full control over the employment, direction, compensation and discharge of all persons employed by Contractor who are assisting in the performance of services under this contract. Contractor shall be fully responsible for all matters. Contractor shall be responsible for its own acts and those of its agents and employees during the term of this contract.
- 63. INTERPRETATION.** County Connection's determination of meaning and intent of any ambiguities in this contract shall be final and conclusive, except that such decision shall not preclude the Contractor from exercising its rights and remedies under the law.
- 64. CORRESPONDENCE.**
- A. All correspondence must show County Connection's project number: 2026-MA-01.
- B. For further information or to view the project site, prospective bidders may contact Steve Muhlestein at (925) 680-2100 between the hours of 8:00 a.m. to 3:30 p.m., Monday through Friday, holidays excepted. All requests for clarification and general questions should be emailed to Steve Muhlestein at muhlestein@cccta.org.
- 65. TIME OF ESSENCE.** Time is of the essence in this contract. Refer to General Condition Paragraph 41-Liquidated Damages.
- 66. INSURANCE PROVISIONS.**
- Refer to Contract, Section 7.
- 67. ACCEPTANCE OF CONTRACT.** When County Connection's designated staff person has made the final inspection of the Contractor's work and determined that the work has been completed in all respects in accordance with the bid documents, he or she will recommend that County Connection formally accept the contract.
- 68. MEASUREMENT AND PAYMENT.** The Contractor shall accept the compensation, as provided in the Contract Documents, as full payment for: furnishing all labor, materials, tools, equipment, disposal and incidentals necessary to the completed Work; performing all Work contemplated under the contract; loss or damage arising from the nature of the Work, or from the action of the elements, or from any unforeseen difficulties which may be encountered during the prosecution of the Work; expenses incurred in consequence of the suspension or discontinuance of the Work as specified in the Contract Documents; and for completing the Work according to the Contract Documents. Neither the payment of any estimate nor of any retained percentage shall relieve the Contractor of any obligation to make good any defective Work or material. No compensation will be made for loss of anticipated profits. Increased or decreased Work involving Change Orders will be paid for as provided in those documents.
- 69. IFB SCHEDULE.** Listed below is the IFB schedule which outlines pertinent dates of which bidders should make themselves aware:
- A. Date of Issuance – February 25, 2026

B. Pre-Bid Meeting - 10:00 AM, MARCH 9, 2026

C. Deadline for Request for Approved Equals, Modifications, or Clarifications - 5:00 PM, MARCH 16, 2026

D. County Connection's response to Requests for Approved Equals, Modifications or Clarifications – MARCH 23, 2026

E. Bid Opening Date - 2:00 PM, March 26, 2026

- 70. INSPECTION OF WORK.** Unless otherwise stated in the specifications, County Connection shall perform all required inspections. All work is subject to inspection and approval of the Project Manager or their designee. The Contractor shall notify the Project Manager at least one (1) working day before inspection is required. The Project Manager shall at all times have access to the work during its construction at shops and yards as well as the project site. The Contractor shall provide every reasonable facility for ascertaining that the materials and workmanship are in accordance with the Contract Documents. Inspection of the work shall not relieve the Contractor of the obligation to fulfill all conditions of the contract.

Inspections will occur Monday through Friday, 8:00 AM to 3:30 PM.

Final Completion

After the Contractor has completed the work on the punch list (if any), the Contractor may make a written request for final inspection.

- 71. PATENTS, INFRINGEMENT OF**

The Contractor agrees that it will, at its own expense, defend all suits or proceedings instituted against County Connection, its Directors, members, agents, officers or employees, and pay any award of damages assessed against any or all of them in such suits or proceedings, insofar as the same are based on any claim that the materials or equipment supplied by the Contractor, or any part thereof, or any tool, article, or process used by the Contractor in the manufacture thereof, constitutes an infringement of any patent enforceable in the United States; provided, County Connection gives to the Contractor prompt notice in writing of the institution of the suit or proceeding and permits the Contractor through its counsel to defend the same and gives the Contractor all needed information, assistance and authority to enable the Contractor so to do.

- 72. ACCEPTANCE OF WORK**

A. Substantial Completion

When the Contractor gives notice to County Connection that the work is substantially complete, County Connection will inspect the work to determine if it is substantially complete and will prepare a comprehensive punch list of items to be completed or corrected before final acceptance. The Contractor shall proceed promptly to correct items on the punch list. Failure to include an item on the punch list does not alter the responsibility of Contractor to complete all the work in accordance with the Contract Documents. If subsequent inspections by County Connection disclose additional items needing correction, whether or not included on the initial punch list or not, those items must also be completed.

B. Final Acceptance

Final Acceptance shall occur when County Connection determines that the work is fully completed and in accordance with the Contract Documents. Final acceptance by County Connection will be made in writing and promptly after the Work has been fully completed with final inspection made.

73. PROJECT SCHEDULE

A. Notice to Proceed

Following receipt of a signed contract, bonds and insurance, County Connection shall issue the Contractor a Notice to Proceed, provided that the documents are acceptable to County Connection. Unless stated otherwise, the contract time shall commence upon the receipt date on the Notice to Proceed.

B. Commencement of Work

Work shall commence within thirty (30) days following the receipt date on the Notice to Proceed, and shall be diligently prosecuted to completion within the time required in the IFB.

C. Subcontracting

Unless otherwise indicated by the contract documents, there is no minimum requirement as to the amount of work that must be performed by the prime contractor's own forces.

D. Completion Date

Contract must complete work within sixty (60) calendar days for the commencement of work or by June 30, 2026.

PERFORMANCE BOND

KNOW ALL PERSONS BY THESE PRESENTS, that

WHEREAS, CENTRAL CONTRA COSTA TRANSIT AUTHORITY, hereinafter designated as “COUNTY CONNECTION,” has awarded to _____, hereinafter designated as the “Principal,” a Contract for INSTALLATION OF ABOVE GROUND DIESEL FUEL STORAGE TANKS; and

WHEREAS, said Principal is required under the terms of said Contract and the Specifications therefore to furnish a bond of faithful performance of said Contract,

NOW, THEREFORE, we, the Principal, and _____, as a California-admitted Surety, are held and firmly bound unto the said COUNTY CONNECTION in the penal sum of _____, being a sum equal to the total amount payable under the Contract, for the payment of which sum, well and truly to be made, we bind ourselves, our heirs, executors, administrators and successors, jointly and severally, firmly by these presents.

THE CONDITION OF THIS OBLIGATION IS SUCH, that if the above-bound Principal, or its heirs, executors, administrators, successors, or assigns approved by COUNTY CONNECTION, shall promptly and faithfully perform the covenants, conditions and agreements in the Contract during the original term and any extensions thereof as may be granted by COUNTY CONNECTION, with or without notice to Surety, and during the period of any guarantees or warranties required under the Contract, and shall also promptly and faithfully perform all the covenants, conditions, and agreements of any alteration of the Contract made as therein provided, notice of which alterations to Surety being hereby waived, on Principal’s part to be kept and performed at the time and in the manner therein specified, and in all respects according to their true intent and meaning, and shall indemnify, defend, protect, and hold harmless COUNTY CONNECTION as stipulated in the Contract, then this obligation shall become and be null and void; otherwise it shall be and remain in full force and effect.

No extension of time, change, alteration, modification, or addition to the Contract, or of the work required thereunder, shall release or exonerate Surety on this bond or in any way affect the obligation of this bond; and Surety does hereby waive notice of any such extension of time, change, alteration, modification, or addition.

Whenever Principal shall be and declared by COUNTY CONNECTION to be in default under the Contract, Surety shall promptly remedy the default, or shall promptly do one of the following at COUNTY CONNECTION’s election:

1. Undertake through its agents or independent contractors, reasonably acceptable to COUNTY CONNECTION, to complete the Contract in accordance with its terms and conditions and to pay and perform all obligations of Principal under the Contract, including without limitation, all obligations with respect to warranties, guarantees, and the payment of liquidated damages.
2. Reimburse COUNTY CONNECTION for all costs COUNTY CONNECTION incurs in completing the Contract, and in correcting, repairing or replacing any defects in materials or workmanship and/or materials and workmanship which do not conform to the specifications in the Contract.

Surety’s obligations hereunder are independent of the obligations of any other surety for the performance of the Contract, and suit may be brought against Surety and such other sureties, jointly and severally, or against any one or more of them, or against less than all of them without impairing COUNTY CONNECTION’s rights against the others.

No right of action shall accrue on this bond to or for the use of any person or corporation other than COUNTY CONNECTION or its successors or assigns.

In the event suit is brought upon this bond by COUNTY CONNECTION, Surety shall pay reasonable attorney's fees and costs incurred by COUNTY CONNECTION in such suit.

IN WITNESS WHEREOF, the above bounded parties have executed this instrument under their seals this _____ day of _____, 20____, the name and corporate seal of each corporate party being hereto affixed and these presents duly signed by its undersigned representative, pursuant to authority of its governing body.

Principal

By: _____

By: _____

Surety

Address of Surety

Note: To be signed by Principal and Surety, and signature of individual signing for Surety shall be notarized and evidence of power of attorney attached.

PAYMENT BOND

KNOW ALL PERSONS BY THESE PRESENTS, That

WHEREAS, CENTRAL CONTRA COSTA TRANSIT AUTHORITY (hereinafter referred to as "Obligee") and _____ (hereinafter referred to as "Principal") have entered into a Contract dated _____, and identified as Contract for INSTALLATION OF ABOVE GROUND DIESEL FUEL STORAGE TANKS; and

WHEREAS, under the terms of said Contract Principal is required to furnish a bond securing payment of the claims to which reference is made in Section 9554 of the Civil Code;

NOW, THEREFORE, we, the Principal, and _____, as California-admitted Surety, are held and firmly bound unto the Obligee in the penal sum of _____ Dollars (\$ _____) lawful money of the United States, for the payment of which sum well and truly to be made we bind ourselves, our heirs, successors executors, administrators and successors, jointly and severally, firmly by these presents.

Furthermore, if Principal, or its heirs, executors, administrators, successors, transferees, assigns, or subcontractors, shall fail to pay persons named in Section 9100 of the Civil Code of the State of California, for any materials, provisions, or other supplies or teams used in, upon, for or about the performance of the work contracted to be done, or for any work or labor thereon of any kind, as required by the provisions of California Civil Code Section 9550 et seq., and provided that the persons, companies, or corporations so furnishing said materials, provisions, or other supplies, teams, appliances, or power to be used in, upon for, or about the performance of the work contracted to be executed or performed, or any person, contributing to said work to be done, or any person who performs work or labor upon same, or any person who supplies both work and materials therefor, shall have complied with the provisions of Section 9550 et seq., then said Surety will pay the same in or to any amount not exceeding the amount herein above set forth, and also will pay in case suit is brought upon this bond, such reasonable attorney's fee as shall be fixed by the court, awarded and taxed as in the above-mentioned statute provided.

Furthermore, if said Principal, or its heirs, executors, administrators, successors, transferees assigns, or subcontractors, fails to pay amounts due under the Unemployment Insurance Code of the State of California with respect to work or labor performed under this Contract, or any amounts required to be deducted, withheld and paid over to the Employment Development Department from the wages of employees of the Contractors and its subcontractors pursuant to Section 13020 of the Unemployment Insurance Code with respect to such work and labor, the Surety will pay for the same, in an amount not exceeding the sum specified in this bond and will also pay, in case suit is brought upon this bond, a reasonable attorney's fee, to be fixed by the court.

This bond shall inure to the benefit of any person named in Section 9100 of the Civil Code of the State of California so as to give a right of action to such persons or their assigns in any suit brought upon this bond.

This bond is given to comply with Sections 9550 and 9554 of the Civil Code. The liability of the Principal and Surety hereunder are governed by the provisions of said Code, all acts amendatory thereof, and all other statutes referred to therein, including Section 8152 of the Civil Code.

The Surety hereby stipulates and agrees that no change, extension of time, alteration or addition to the terms of the Contract or to the work to be performed thereunder or the specifications accompanying the same shall in any wise affect its obligation on this bond, and it does hereby waive notice of any such change, extension of time, alteration or addition to the terms of the Contract or to the work or to the specifications.

IN WITNESS WHEREOF, the above bounded parties have executed this instrument under their seals this _____ day of _____, 20_____, the name and corporate seal of each corporate body being hereto affixed and these presents duly signed by its undersigned representative, pursuant to authority of its governing body.

Note: To be signed by Principal and Surety and acknowledgment and notarial seal attached.

Principal

By _____

By _____

Surety

By _____

By _____

APPROVED EQUAL FORM

INSTALLATION OF ABOVE GROUND DIESEL FUEL STORAGE TANKS
2026-MA-01

IMPORTANT: USE A SEPARATE FORM FOR EACH SEPARATE SOLICITATION, PROVISION, OR SPECIFICATION ITEM REQUEST. COPY THIS FORM AS NEEDED.

Submitted by: _____ (Company Name)

County Connection requires that all prospective bidders completely fill out and attach this form **with every separate specification item request** for an Approved Equal pertaining to this Contract. Failure to completely fill out this form and submit with the request may result in denial of the request. Any further information that may be useful in reviewing such a request should also be attached to this form.

All Requests for Approved Equals shall be emailed to County Connection’s Chief Financial Officer, Amber Johnson, at ajohnson@cccta.org or County Connection’s Facility Superintendent, Steve Muhlestein, at muhlestein@cccta.org.

1. A. Approved equal is being requested for _____,
to be used in place of _____
(list technical specification or other reference number, [e.g., page TS-1, title, subsection, item]).

B. Page Number _____

C. Section Number and Heading _____
2. Description of approved equal request/substitution: _____
_____.
3. Product purpose: _____
_____.
4. Does this proposed approved equal request/substitution meet all applicable federal, state and local laws and regulations? _____ (If NO, please explain): _____
_____.
5. List three commercial firms within the United States, which have used the proposed approved equal request/substitution (list California properties first):
 - A. Company Name _____
Street Address _____
City/State/Zip Code _____
Telephone No. (_____) _____
Name of Contact Person _____
 - B. Company Name _____
Street Address _____
City/State/Zip Code _____
Telephone No. (_____) _____
Name of Contact Person _____
 - C. Company Name _____
Street Address _____
City/State/Zip Code _____
Telephone No. (_____) _____
Name of Contact Person _____

6. List the benefits and any other reasons why County Connection should approve this request for approved equal/substitution: _____
_____.
7. Attach pertinent test data, technical data, and background information on the approved equal/substitution request.

TECHNICAL SPECIFICATIONS

INSTALLATION OF ABOVE GROUND DIESEL FUEL STORAGE TANKS

County Connection is requesting bids to install (2) new double wall 25,000-gallon aboveground storage tanks (AST). The existing 20,000-gallon double wall tank will stay in place. Existing piping needs to be capped and protected from damage during construction. The existing tank and two new AST tanks will need to be manifolded together with double wall piping from pump turbines back to existing piping. The new ASTs will also require installation of (2) new Vedder-Root Red Jacket turbines.

Contractor will:

- Apply for permits from Contra Costa County Environmental Health Department (CCHD) and Contra Costa County Fire Protection District.
- Comply with CCHD above ground storage tank installation requirements.
- Mark site and notify USA North/Dig alert a minimum of 72 hours prior to any excavation.
- Provide temporary fence around work area and install site Best Management Practices (BMPs) per Water Pollution Control Plan and Stormwater Pollution Prevention Plan (SWPP) plan.
- Sawcut, break, remove, existing concrete where new piping will meet existing in ground double wall piping. Remove and dispose of existing soil and pea gravel.
- Excavate planter area to 36' native soil compacted, add 6' of class 11 base and recompact to 90%. #5 rebar installed and concrete depth as show on plans provided. Removal of all spoils and dispose of properly.
- Pour new concrete at planter strip adjacent to bus wash building area to match height of existing concrete curb. Concrete pad depth, length, width and rebar pattern shown on included drawings. Concrete mix shall be 3500 psi @ 28-day 6 sack $\frac{3}{4}$ mix.

- Install two (2) new 25,000-gallon aboveground storage tanks in planter strip adjacent to the existing double underground storage tank (UST). Tanks must be installed in accordance with manufacturer recommendations. Tanks will comply with the California Fire Marshall's Aboveground Petroleum Storage Act (APSA) as well with Unified Program Agencies (UPA) Spill Prevention, Control, and Countermeasure Plan (SPCC) requirements, Title 23 UST Regulations, and United States Environmental Protection Agency's CFR 40 regulations.
- Install (2) new Veeder-Root The Red Jacket STP 2 HP, 60 HZ manifolded turbine pumps. One turbine per each 25,000-gallon tank being installed.
- Installation of tank monitors, interstitial monitors, line monitors and wiring back to the Veeder-Root TLS will need to be done.
- Install new TLS- 450PLUS ATG console with 8-inch WVGA color touch screen display, printer, 3 ethernet and dual USB/expansion, dual RS-232/RS-485. ULC/UL (333545-001 required)
- Pipe new secondary containment lines to manifold (2) new tanks to the existing double wall tank. Pipe into existing piping supplying existing dispensers.
- Replace existing pea gravel that was excavated. Add additional pea gravel back fill as needed.
- Backfill, compact and run #5 rebar at 2-foot intervals, dowel into existing slab minimum 12-inch depth epoxy in place.
- Pour new concrete into all areas where new piping has been run to match height and depth removed. Concrete mix shall be 3500 psi @ 28-day 6 sack $\frac{3}{4}$ mix.
- Removal of fencing, cleanup of job site (all construction debris) berms, straw waddles, barriers, and spoils upon completion of project. Project needs to be clean and contained at the end of each workday as County Connection's operations will continue during construction.

DOCUMENTATION:

- Contractor license requirements- A- general engineering, HAZ- Hazardous substance removal certification
- Schedule of values for complete project along with milestones.
- Complete Gantt chart including stipulations for inclement weather.
- Time is of the essence clause will be implemented.
- All insurance limits and policy information based on Contract requirements.
- Performance and payment bond.
- Liquidated damages clause

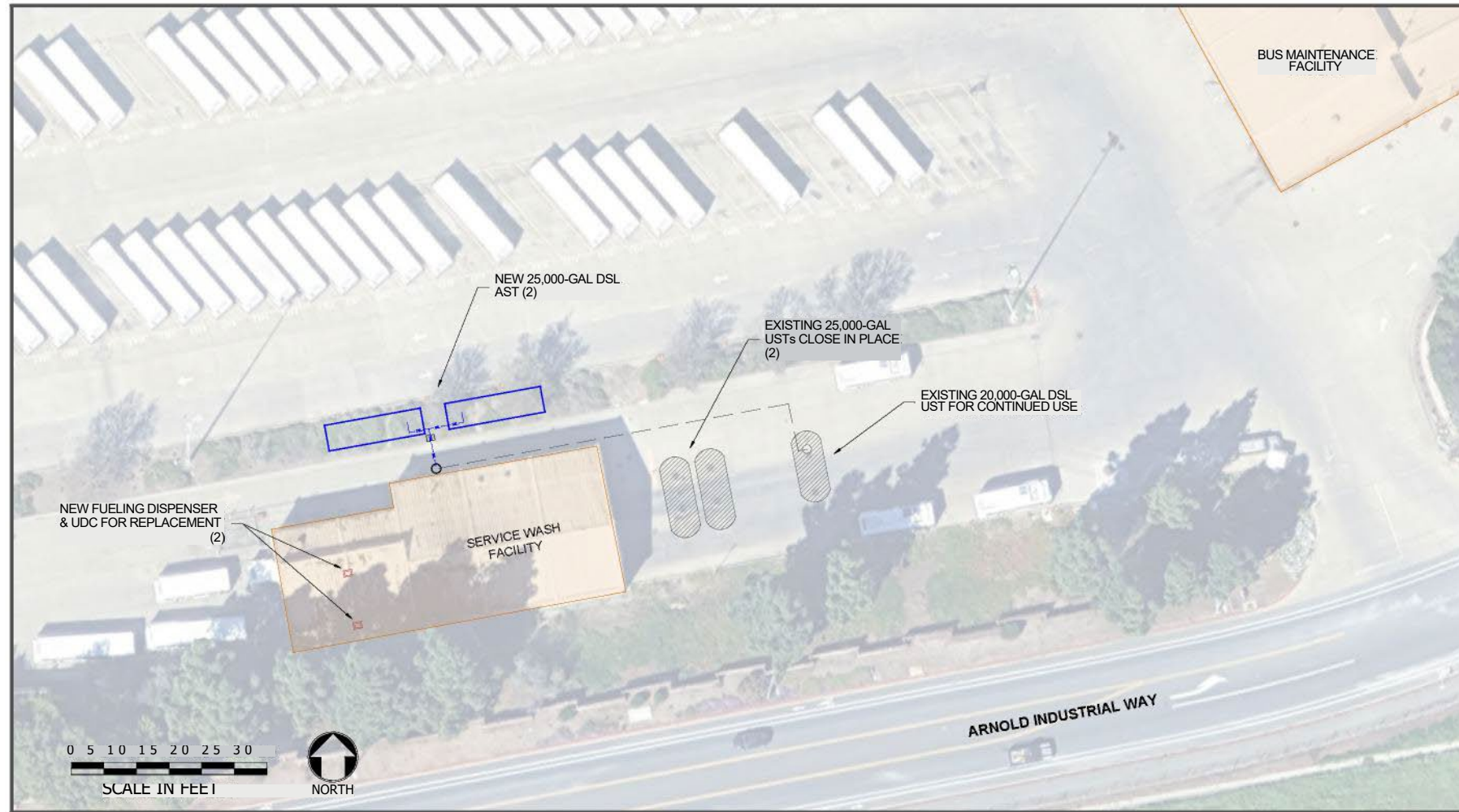

County Connection

2477 ARNOLD INDUSTRIAL WAY, CONCORD, CA 94520

CLIENT	CONTRACTOR	ENGINEER
COUNTY CONNECTION	CGRS, INC.	CGRS, INC.
CONTACT: COUNTY CONNECTION 2477 ARNOLD INDUSTRIAL WAY CONCORD, CA 94520	CONTACT: RICHARD THOMAS 5444 DRY CREEK ROAD SACRAMENTO, CA 95838 PH#: (510) 536 0774	CONTACT: JOHN PORCELLA P.E. 1301 ACADEMY CT. FORT COLLINS, CO 80524 PH#: (970) 493-7780

SCOPE OF WORK

- CLOSE IN PLACE TWO (2) 25,000-GAL SINGLE WALL DIESEL USTs. INSTALL TWO (2) NEW 25,000-GAL DOUBLE WALL DIESEL ASTs. CONNECT NEW DIESEL PIPING FROM ASTs AND MANIFOLD TO EXISTING 20,000-GAL DOUBLE WALL DIESEL UST. REPLACE EXISTING FUEL DISPENSER & UDC (2) WITH NEW FUEL DISPENSER & UDC (2).
- EXCAVATE TRENCH AND DISCONNECT EXISTING DIESEL PIPING FROM TWO (2) 25,000-GAL USTs. CAP PIPING TO PROTECT FROM DAMAGE DURING CONSTRUCTION.
 - CLOSE IN PLACE TWO (2) 25,000-GAL DIESEL USTs. REMOVE PRODUCT AND TRIPLE RINSE TANKS. DISPOSE OF RINSEATE BY LICENSED HAULER UNDER HAZARDOUS WASTE MANIFEST.
 - CUPA INSPECTION. LAB ANALYZE SOIL SAMPLES FOR CUPA APPROVAL PRIOR TO CLOSING AND FILLING TANKS WITH CLSM SLURRY.
 - SET IN PLACE TWO (2) NEW MODERN WELDING UL-2085 25,000-GAL DOUBLE WALLED DIESEL ASTs IN COMPLIANCE WITH LOCAL, STATE, AND FEDERAL REGULATIONS.
 - MANIFOLD UNDERGROUND DOUBLE WALLED FIBERGLASS REINFORCED PLASTIC (FRP) PIPE, 3" OVER 2", TO 20,000-GAL DOUBLE WALL DIESEL UST PIPING. CALL FOR INSPECTIONS.
 - INSTALL NEW ELECTRICAL CONDUIT FROM AST'S TO BUILDING. CALL FOR INSPECTIONS.
 - REMOVE EXISTING UST SENSORS AND REINSTALL INSIDE NEW TLS450 TRANSITION SUMP INSTALLATION.
 - INSTALL CONCRETE COVER. BACKFILL EXCAVATED AREAS AND POUR NEW CONCRETE TO MATCH EXISTING.
 - INSTALL AST ANCILLARY EQUIPMENT AND VENTING.
 - REPLACE FUEL DISPENSERS AND UDC'S LOCATED INSIDE BUS WASH FACILITY. REMOVE

DESIGN STANDARDS

- DESIGN STANDARDS
- NATIONAL FIRE PROTECTION ASSOCIATION (NFPA) NFPA 30, NFPA 30A.
 - ANSI/ASME B31.3
 - PEI/RP200-24 RECOMMENDED PRACTICES FOR INSTALLATION OF ABOVEGROUND STORAGE SYSTEMS FOR MOTOR VEHICLE FUELING.
 - UNDERWRITERS LABORATORY, INC UL-2085 STANDARD FOR PROTECTED ABOVEGROUND TANKS FOR FLAMMABLE & COMBUSTIBLE LIQUIDS.
 - UL-567 A&B STANDARD FOR EMERGENCY BREAKAWAY FITTINGS, SWIVEL CONNECTORS AND PIPE CONNECTION.
 - UNDERWRITERS LABORATORY, INC UL-1316 FIBER REINFORCED UNDERGROUND TANKS FOR FLAMMABLE & COMBUSTIBLE LIQUIDS.

DESIGN CODES

- DESIGN CODES
- 2022 CALIFORNIA BUILDING CODE
 - 2022 CALIFORNIA FIRE CODE
 - 2022 CALIFORNIA MECHANICAL CODE
 - 2022 CALIFORNIA ELECTRICAL CODE

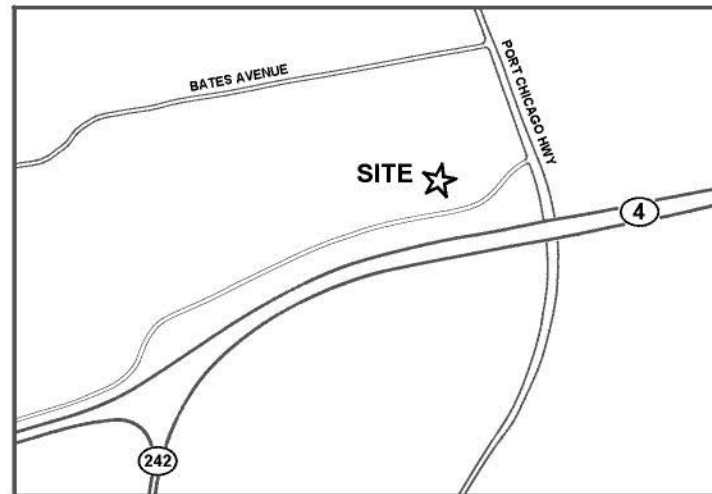

LEGEND	
	PROPOSED AST/FUELING LOCATION
	NEW DIESEL PIPING
	TRENCH EXCAVATION
	EXISTING PRODUCT PIPING
	BUILDING
	ELECTRICAL

SHEET #	TITLE
G-100	TITLE SHEET
G-200	GENERAL LAYOUT
C-100	CONCRETE DETAILS I
C-200	CONCRETE DETAILS II
M-100	GENERAL TANK LAYOUT & TESTING
M-200	PIPING, SUMPS & INSTRUMENTATION
M-300	AST DETAILS
M-400	BOM

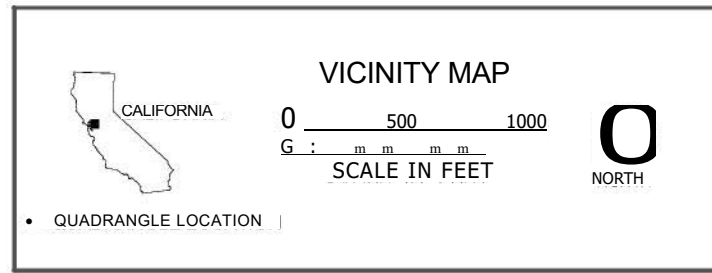

NOT TO SCALE
 VISUALS ARE APPROXIMATE AND NOT TO BE USED FOR CONSTRUCTION PURPOSES WITHOUT THE WRITTEN CONSENT OF THE ENGINEER OF RECORD AND CGRS, INC.

SHEET TITLE: TITLE SHEET

REV	DATE	REVISIONS	DRAWN BY

PROJECT INFORMATION:
 DATE: 2/11/25
 SHEET: G-100

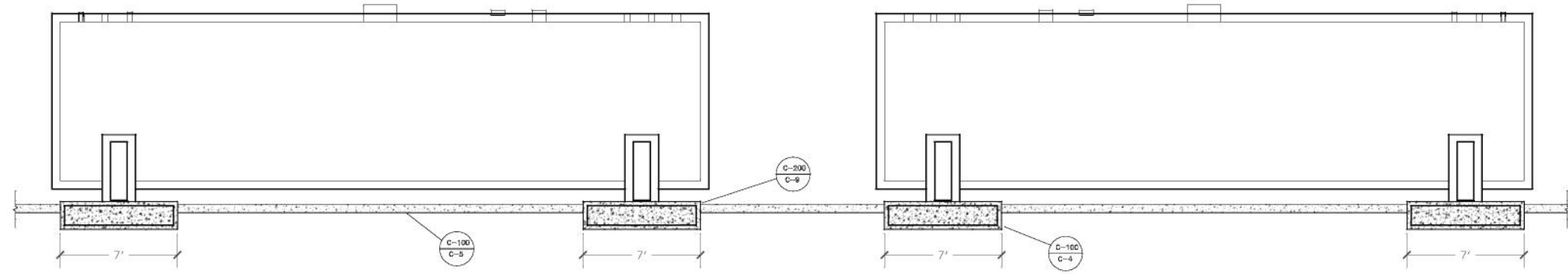

C 1 TANK PEDESTAL SIDEVIEW
NTS

CONCRETE NOTES:

- GOVERNING DESIGN CODES:
 A. CALIFORNIA BUILDING CODE 2022
 B. ASCE 7-22
 C. ACI 318-19
 D. ASTM C33
 E. ASTM C150

DESIGN CRITERIA:

- A. WIND (PER ASCE 7-22) EXPOSURE RISK GUST SPEED 87 MPH
 B. SEISMIC CRITERIA
 SS 221
 S1 0.69
 SDS 1.53
 TL 8

SOIL CLASS DEFAULT
 RISK CATEGORY IV

CONCRETE:

CONCRETE USE	FOUNDATION TANK SLAB	HOUSEKEEPING SLAB
COMP. STRENGTH f_c (psi)	2,500	2,500
EXPOSURE CLASS	F0	F0
CEMENT TYPE	I	I
MAX RATIO w/cm	0.5	0.5
AIR CONTENT	5.0 (+/-) 2%	5.0 (+/-) 2%
SLUMP LIMIT	4" (+/-) 1.0"	4" (+/-) 1.0"

- a. AGGREGATE SIZE 3/4"
 b. ALL CONCRETE WORK AND REINFORCEMENT SHALL COMPLY WITH ACI BUILDING CODES LATEST EDITION UNLESS NOTED ELSEWHERE ALL EXPOSED EDGES SHALL HAVE 3/4 INCH CHAMFER.
 c. ALL CONCRETE SHALL BE STONE CONCRETE UTILIZING AGGREGATE CONFORMING TO ASTM C33. CEMENT SHALL BE TYPE V CONFORMING TO ASTM C150 MAXIMUM WATER-CEMENT RATIO SHALL BE 0.5 BY WEIGHT.
 d. ALL CONCRETE WITH A COMPRESSIVE STRENGTH IN EXCESS OF 2,500 PSI AT 28 DAYS SHALL BE PLACED UNDER SUPERVISION OF A DEPUTY INSPECTOR LICENSED BY THE LOCAL BUILDING OFFICIAL.
 e. ALL CONCRETE MIXES SHALL CONFORM TO THE PROPORTIONS ESTABLISHED BY THE CODE FOR THE VARIOUS CONCRETE STRENGTHS REQUIRED TO WORK. CONTRACTOR SHALL ENGAGE A CERTIFIED INDEPENDENT TESTING LABORATORY TO PREPARE 6 DESIGNS FOR THE WORK. COPIES OF THE MIX DESIGN, AS WELL AS 7-DAY AND 28-DAY CYLINDER TEST RESULTS SHALL BE SENT TO THE ENGINEER AND THE LOCAL BUILDING OFFICIAL TO OBTAIN APPROVAL PRIOR TO ITS USE IN THE WORK.
 f. ALL CONCRETE WORK SHALL BE IN ACCORDANCE WITH THE ACI 318-14 AND THE SPECIFICATION FOR CAST-IN-PLACE CONCRETE.
 g. A 3/4-INCH CHAMFER SHALL BE PROVIDED AT ALL EXPOSED EDGES OF CONCRETE U.N.O. IN ACCORDANCE WITH ACI 301 SECTION 4.2.4

FOUNDATION:

- A. ASSUME MAXIMUM SOIL DESIGN PRESSURE 2,000 PSF
 B. UNUSUAL SITE SOIL CONDITIONS (CLAY OR DISPOSAL FILL) SHALL BE BROUGHT TO THE ATTENTION OF THE ENGINEER.
 C. FOOTINGS SHALL BE PLACED ON OVER-EXCAVATED SOIL & RE-COMPACTED TO 90% STANDARD PROCTOR DENSITY. COMPACTION SHALL MEET A MINIMUM OF 2,000 PSF.
 D. COMPACT CLASS II BASE AGGREGATE TO 95% STANDARD PROCTOR DENSITY.

REINFORCEMENT:

- A. ALL REINFORCEMENT SHALL BE DEFORMED BARS CONFORMING TO ASTM A615, GRADE 60.
 B. REINFORCEMENT PROTECTION SHALL HAVE 3 INCHES OF CONCRETE.
 C. ALL REINFORCEMENT TO BE HELD SECURELY IN PROPER POSITION IN ACCORDANCE WITH THE LATEST EDITION OF ACI-318.

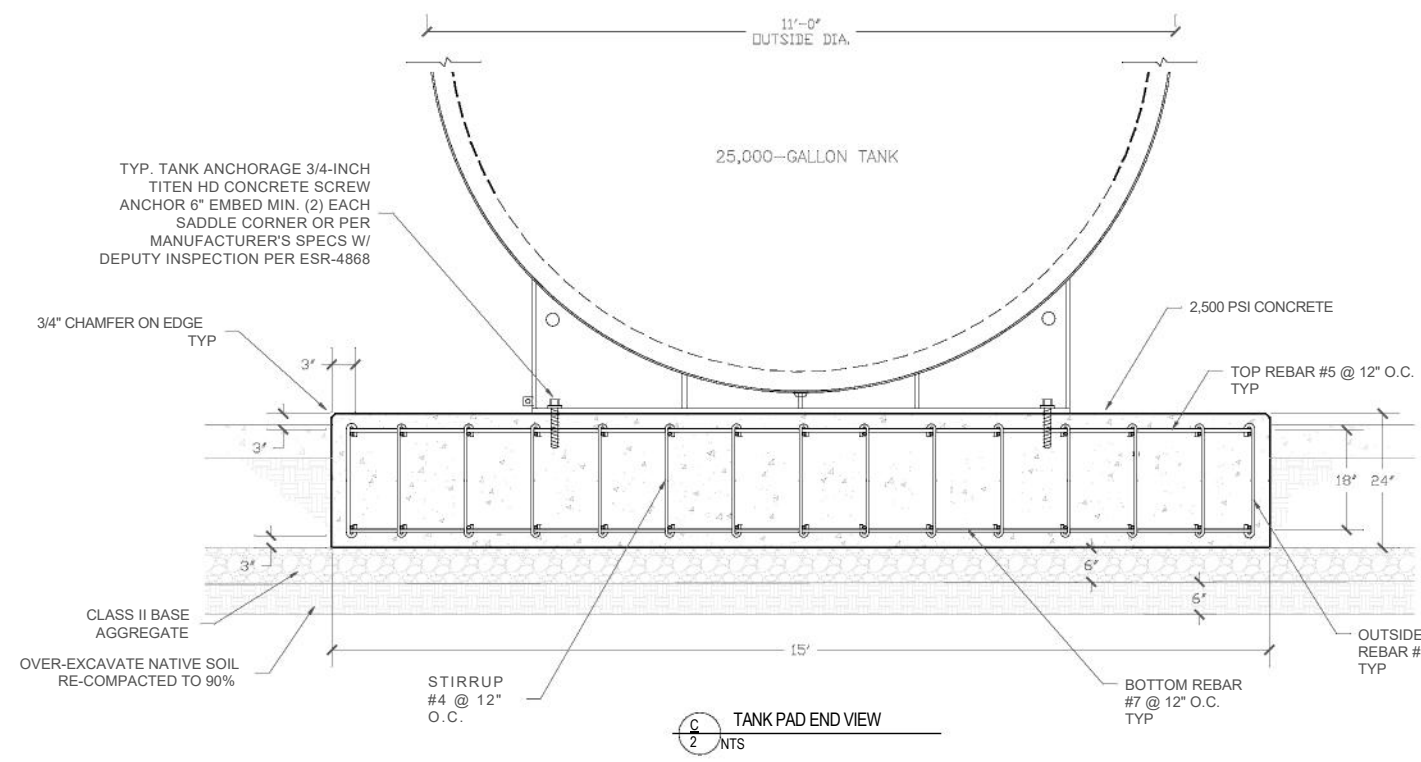

C 2 TANK PAD END VIEW
NTS

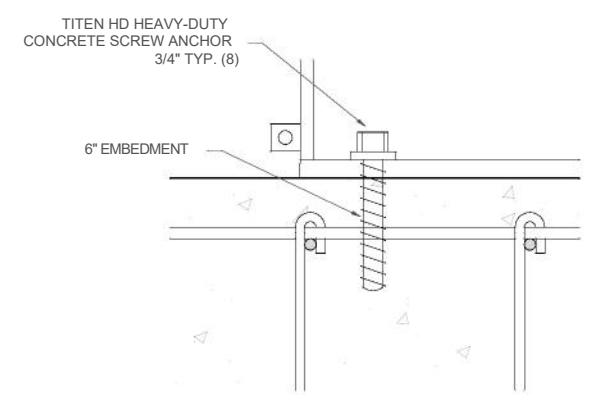

C 3 ANCHORING SIDEVIEW
NTS

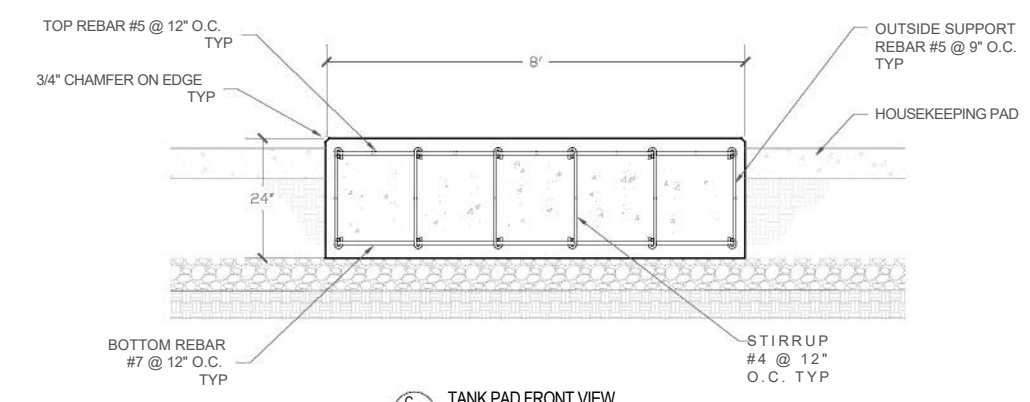

C 4 TANK PAD FRONT VIEW
NTS

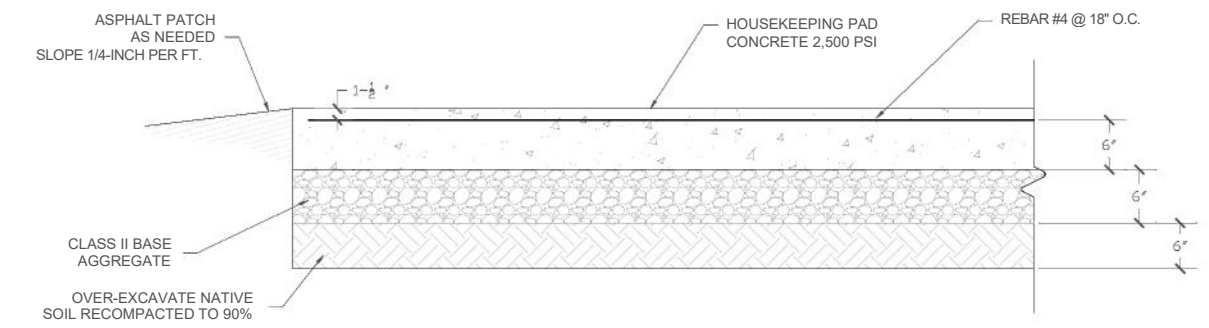

C 5 HOUSEKEEPING PAD
NTS



NOT TO SCALE
 REVISIONS FROM THE ORIGINAL SHALL BE INDICATED BY A NUMBER IN THE MARGINS

SHEET TITLE
 CONCRETE DETAILS I

NO.	DATE	REVISIONS



PROJECT INFORMATION:
 DATE: 2/10/2025 DRAWN BY: JH
 SITE #: 20771 PROJECT #: 23566
 SHEET: C-100

E

D

C

B

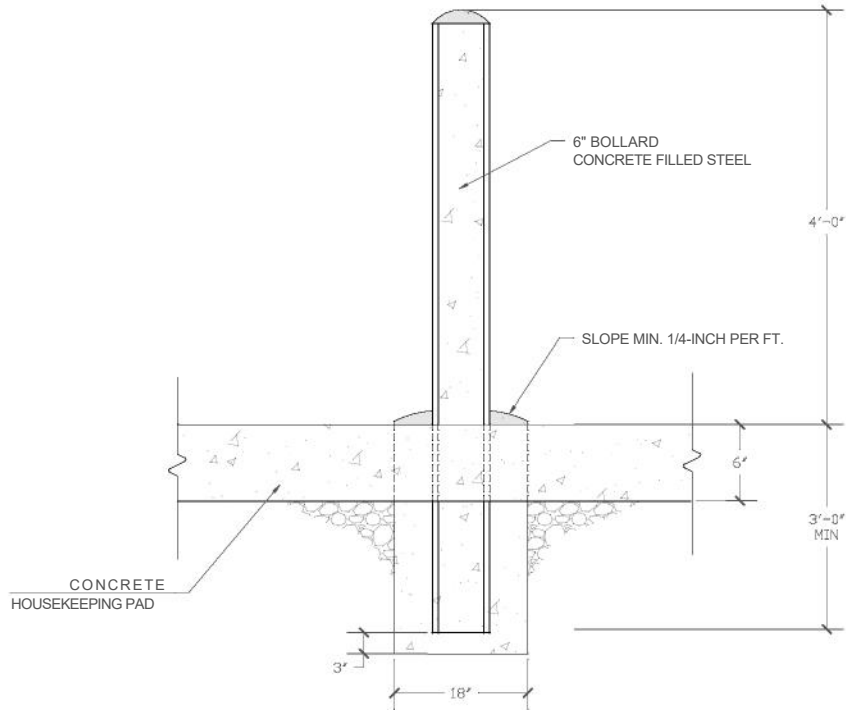

C
6 BOLLARD DETAILS
NTS

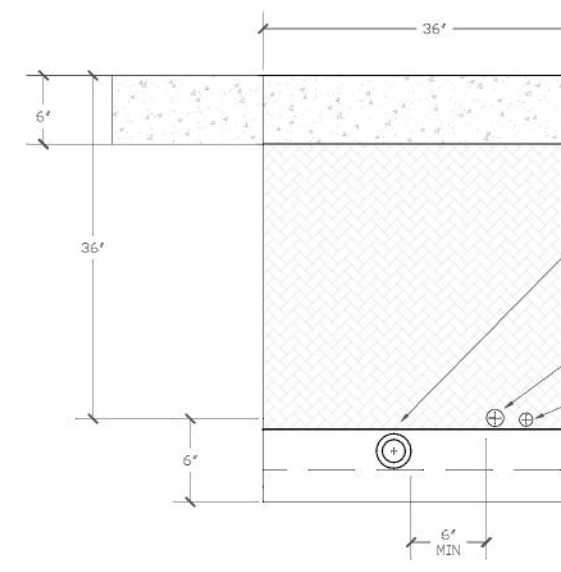

C
7 TRENCH DETAILS
NTS

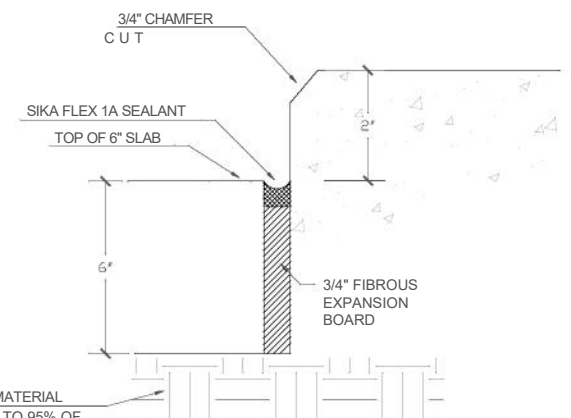
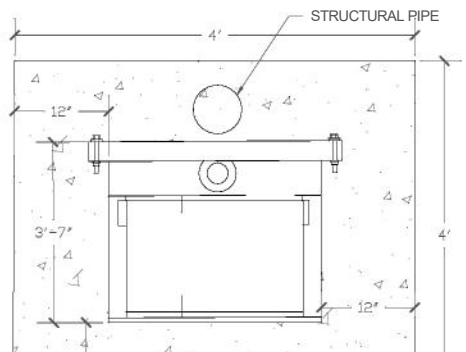

Shop Fabricated Stationary Aboveground Storage Tanks For Flammable, Combustible Liquids
INSTALLATION INSTRUCTIONS
R912

November 2015

1 TANK SITE EVALUATION AND PREPARATION
1.1 PRIOR TO INSTALLATION
 The foundation for the tank must be designed to support the tank plus 100% of its contents when full. The design shall also take into account the type of support that is being used and the point load associated with that support. The foundation may be constructed using concrete, asphalt, gravel or other stable material and must include provisions in its design to prevent tank movement. The foundation should include any provisions necessary for seismic design. The foundation design must also include provision for draining surface water away from the tank.

1.2 For tank installations without cathodic corrosion protection, the tank should be grounded in accordance with applicable electrical and fire code standards.

1.3 Where the steel tank body is in contact with the earth, use a zinc-grounding rod. Do not use a copper grounding rod.

1.4 Where the tank body is in contact with the earth or foundation, it should be protected from external corrosion. For external corrosion protection using cathodic corrosion protection, consult applicable standards (e.g., National Association of Corrosion Engineers) to provide the tank with appropriate protection from lightning without interfering with the corrosion protection. Steel tanks in contact with the earth should not use copper grounding. Refer to STI NSS-455, Recommended Practice for External Corrosion Protection Shop Fabricated Aboveground Storage Tank Floors.

1.5 Tanks located in areas subject to flooding must be protected against flotation.

1.6 Aboveground tanks should not be located above underground utilities or directly beneath overhead power lines. The tank shall be protected from vandalism and accidental damage in accordance with all applicable codes, NFPA 30, NFPA 30A, UFC, etc.

3.1.1.1 Caution must be taken in applying a vacuum to the interface of a tank and the testing may be stopped if any deformation appears on the tank.

3.2 AIR PRESSURE TEST PROCEDURE FOR TANKS
3.2.1 If the tank is equipped with a long-bolt manway for emergency venting, do not remove the long-bolt manway from the long-bolt manway. Instead, long-bolt manways must be secured with C-clamps of appropriate size and strength to hold the vent cover in the sealed position to maintain the tank pressures required. If tank is equipped with standard emergency vents, remove emergency vents and cap openings to hold tank pressure as required.

3.2.2 Use only calibrated air pressure gauges with a 0-15 psig (0-0.3 MPa) dial span. The relief valve must have a flow rate at the set pressure that is greater than the flow rate of the air supply line. The required air supply test pressure used for this test should be as follows:

a. HORIZONTAL CYLINDRICAL (AND DOME) TANKS, IF APPLICABLE TANKS - NOT LESS THAN 3 PIGS (20.7 kPa) NOR MORE THAN 5 PIGS (34.5 kPa). Set the pressure relief valve in the air supply line at 5 psig (38 kPa).

b. VERTICAL TANKS - NOT TO LESS THAN 1 1/2 PIGS (10.4 kPa) NOR MORE THAN 2 1/2 PIGS (17 kPa) OR THAT GAUGE PRESSURE ABOVE 1 1/2 PIGS (10.4 kPa) WHICH FIRST CAUSES VISIBLE DEFORMATION OF THE TANK. Set the pressure relief valve in the air supply line at 1 1/2 psg (10.4 kPa).

c. RECTANGULAR TANKS - NOT MORE THAN 1 1/2 PIGS (10.4 kPa). Set the pressure relief valve in the air supply line at 1 1/2 psg (10.4 kPa). This 1 1/2 psg (10.4 kPa) pressure is to be used for testing tanks in the field ONLY.

3.2.3 In lieu of the air pressure test described in paragraph 3.1.2 below, a vacuum may be applied to the interface of a double-wall tank or to the interface of a double-bottom tank.

3.1.2 NOTE: This test procedure may be difficult to conduct for large (greater than 2000 gallons) tanks because of the greater volume of space to be evacuated and difficulty in sealing the tank openings. DO NOT APPLY A VACUUM TO THE PRIMARY TANK OF A DOUBLE-WALL TANK OR TO A SINGLE-WALL TANK. A vacuum of 6 inches Hg (20.3 kPa) is to be applied to the interface. The vacuum shall be held without a loss for one hour on tanks less than 20,000 gallons and for 2 hours for tanks greater than or equal to 20,000 gallons. If this vacuum cannot be held for the specified time interval, then perform the air test procedure described in paragraph 3.2.

3.2.2 SINGLE-WALL TANK PRESSURIZING PROCEDURE
3.2.2.1 Initial test, piping as shown in Figure 3.2.2.1 temporarily plug cap or seal off remaining tank openings to hold pressure.

3.2.2.2 Close valve A and B.
3.2.2.3 Connect regulated test air supply line to test piping as shown in Figure 3.2.2.1.
3.2.2.4 Slowly open valve A to pressurize the tank. Pressure gauge 1 should indicate test air pressure given in paragraph 3.2.1 above. Close valve A. Disconnect regulated test air supply line from test piping.
3.2.2.5 Proceed to paragraph 3.2.4 "Detection of Leaks" below.

3.2.3 DOUBLE-WALL TANK PRESSURIZING
3.2.3.1 The following air pressure testing does not apply to double-wall tanks equipped with interstitial vacuum monitoring systems. In lieu of the air pressure test, the tank may be shipped from the factory with a vacuum in the tank interstice.
 Read and record the vacuum pressure. If the vacuum pressure, gauge reading is less than 12 inches Hg (40.5 kPa) contact the tank manufacturer.
3.2.3.2 Temporarily plug cap or seal off remaining tank openings to hold pressure.
3.2.3.3 Close valves A and B. Open valve C.
3.2.3.4 Connect regulated test air supply line to test piping as shown in Figure 3.2.3.2.
3.2.3.5 Slowly open valve A to pressurize the primary tank. Pressure gauge 1 should indicate test air pressure given in paragraph 3.2.1 above.

3.2.3.6 Close valve A. Disconnect regulated test air supply line from test piping.
3.2.3.7 Monitor test pressure in primary tank for 1 hour minimum. A steady drop in pressure reading for gauge 1 indicates there may be a leak in the primary tank. Check the fittings, and gauge, then retest. If the problem persists, contact the tank manufacturer.

3.2.4 DETECTION OF LEAKS
3.2.4.1 Immediately apply leak test solution to tank exterior surfaces, welds, fittings, etc. Check for leaks. No leaks are permitted. If leaks are found, notify the tank manufacturer. If no leaks are found, testing of the tank is complete.
3.2.4.2 For single-wall tank, open valve B, then slowly open valve A to release test air pressure. For double-wall tank, open valve C, then slowly open valve B to release test air pressure.
3.2.4.3 WARNING: Emergency relief vents and long bolt manways must be operable to prevent causing tank failure by over-pressurization.
3.2.4.4 TANK PIPING AND ACCESSORIES
 Install all permanent piping and fittings using compatible, non-hardening threaded sealant material. All unused tank openings must be properly sealed and vented to be liquid and vapor tight prior to putting the tank into service.

3.2.4.5 DO NOT WELD ON THE TANK, MODIFY OR PENETRATE THE TANK STRUCTURE IN ANY WAY WITHOUT THE EXPRESS WRITTEN PERMISSION OF THE TANK MANUFACTURER.
 All tank accessories shall be installed as required per local codes. Anti-siphon devices, overflow shut-offs and alarms, vents, gauges, emergency vents, etc. are common requirements for tanks storing motor fuels for the purpose of being dispensed into motor vehicles.
5 MAINTENANCE
5.1 The tank operator should perform periodic walk-around inspections to identify and repair areas of damage to the tank or the coating. Check for proper drainage around the tank area.
5.2 It is imperative that the tank exterior be inspected periodically to ensure that the integrity of the coating is maintained. The frequency of periodic repainting will be based upon environmental factors in the geographic area where the tank is located. Special consideration should be given to the selection of the paint, surface preparation and coating application. The coating selected should be suitable for use with the current coating, or the existing coating should be removed. The coating selected should be of industrial quality.
5.3 Proper site preparation and maintenance are vital to ensure drainage of surface water. Should ground conditions change or settlement occur, take the appropriate steps to maintain proper drainage and prevent standing water near or under the tank area.
5.4 For diked tanks, remove any product spills immediately. Be sure to dispose of hazardous material properly.
5.3.2 For diked tanks fitted with a drain, drain off water only. Drain openings are required to be maintained liquid tight.
5.4 The primary tank should be inspected monthly for the presence of water at the lowest possible points inside the primary tank. Remove any water found. Water and sediment in fuel can cause plugging of filters. Also, bacterial growth, in this media, can cause filters to plug and cause corrosion of tanks and lines. For procedures on how to check for the presence of water and removal of water, refer to STI RP111, Storage Tank Maintenance. For copies of the RP and more information, please go to www.stitank.com.
5.5 Tank relocation requirements - Aboveground storage tanks are often relocated. The following instructions are to be followed when this occurs. All steps are to be documented and the documentation is to be kept for the life of the tank.
5.3.10 Proceed to paragraph 3.2.4 "Detection of Leaks" below.
3.2.4 DETECTION OF LEAKS
3.2.4.1 Immediately apply leak test solution to tank exterior surfaces, welds, fittings, etc. Check for leaks. No leaks are permitted. If leaks are found, notify the tank manufacturer. If no leaks are found, testing of the tank is complete.
3.2.4.2 For single-wall tank, open valve B, then slowly open valve A to release test air pressure. For double-wall tank, open valve C, then slowly open valve B to release test air pressure.
3.2.4.3 WARNING: Emergency relief vents and long bolt manways must be operable to prevent causing tank failure by over-pressurization.
3.2.4.4 TANK PIPING AND ACCESSORIES
 Install all permanent piping and fittings using compatible, non-hardening threaded sealant material. All unused tank openings must be properly sealed and vented to be liquid and vapor tight prior to putting the tank into service.

4.3 DO NOT WELD ON THE TANK, MODIFY OR PENETRATE THE TANK STRUCTURE IN ANY WAY WITHOUT THE EXPRESS WRITTEN PERMISSION OF THE TANK MANUFACTURER.
 All tank accessories shall be installed as required per local codes. Anti-siphon devices, overflow shut-offs and alarms, vents, gauges, emergency vents, etc. are common requirements for tanks storing motor fuels for the purpose of being dispensed into motor vehicles.
5 MAINTENANCE
5.1 The tank operator should perform periodic walk-around inspections to identify and repair areas of damage to the tank or the coating. Check for proper drainage around the tank area.
5.2 It is imperative that the tank exterior be inspected periodically to ensure that the integrity of the coating is maintained. The frequency of periodic repainting will be based upon environmental factors in the geographic area where the tank is located. Special consideration should be given to the selection of the paint, surface preparation and coating application. The coating selected should be suitable for use with the current coating, or the existing coating should be removed. The coating selected should be of industrial quality.
5.3 Proper site preparation and maintenance are vital to ensure drainage of surface water. Should ground conditions change or settlement occur, take the appropriate steps to maintain proper drainage and prevent standing water near or under the tank area.
5.4 For diked tanks, remove any product spills immediately. Be sure to dispose of hazardous material properly.
5.3.2 For diked tanks fitted with a drain, drain off water only. Drain openings are required to be maintained liquid tight.
5.4 The primary tank should be inspected monthly for the presence of water at the lowest possible points inside the primary tank. Remove any water found. Water and sediment in fuel can cause plugging of filters. Also, bacterial growth, in this media, can cause filters to plug and cause corrosion of tanks and lines. For procedures on how to check for the presence of water and removal of water, refer to STI RP111, Storage Tank Maintenance. For copies of the RP and more information, please go to www.stitank.com.
5.5 Tank relocation requirements - Aboveground storage tanks are often relocated. The following instructions are to be followed when this occurs. All steps are to be documented and the documentation is to be kept for the life of the tank.

5.1 The tank operator should perform periodic walk-around inspections to identify and repair areas of damage to the tank or the coating. Check for proper drainage around the tank area.
5.2 It is imperative that the tank exterior be inspected periodically to ensure that the integrity of the coating is maintained. The frequency of periodic repainting will be based upon environmental factors in the geographic area where the tank is located. Special consideration should be given to the selection of the paint, surface preparation and coating application. The coating selected should be suitable for use with the current coating, or the existing coating should be removed. The coating selected should be of industrial quality.
5.3 Proper site preparation and maintenance are vital to ensure drainage of surface water. Should ground conditions change or settlement occur, take the appropriate steps to maintain proper drainage and prevent standing water near or under the tank area.
5.4 For diked tanks, remove any product spills immediately. Be sure to dispose of hazardous material properly.
5.3.2 For diked tanks fitted with a drain, drain off water only. Drain openings are required to be maintained liquid tight.
5.4 The primary tank should be inspected monthly for the presence of water at the lowest possible points inside the primary tank. Remove any water found. Water and sediment in fuel can cause plugging of filters. Also, bacterial growth, in this media, can cause filters to plug and cause corrosion of tanks and lines. For procedures on how to check for the presence of water and removal of water, refer to STI RP111, Storage Tank Maintenance. For copies of the RP and more information, please go to www.stitank.com.
5.5 Tank relocation requirements - Aboveground storage tanks are often relocated. The following instructions are to be followed when this occurs. All steps are to be documented and the documentation is to be kept for the life of the tank.

5.1 The tank operator should perform periodic walk-around inspections to identify and repair areas of damage to the tank or the coating. Check for proper drainage around the tank area.
5.2 It is imperative that the tank exterior be inspected periodically to ensure that the integrity of the coating is maintained. The frequency of periodic repainting will be based upon environmental factors in the geographic area where the tank is located. Special consideration should be given to the selection of the paint, surface preparation and coating application. The coating selected should be suitable for use with the current coating, or the existing coating should be removed. The coating selected should be of industrial quality.
5.3 Proper site preparation and maintenance are vital to ensure drainage of surface water. Should ground conditions change or settlement occur, take the appropriate steps to maintain proper drainage and prevent standing water near or under the tank area.
5.4 For diked tanks, remove any product spills immediately. Be sure to dispose of hazardous material properly.
5.3.2 For diked tanks fitted with a drain, drain off water only. Drain openings are required to be maintained liquid tight.
5.4 The primary tank should be inspected monthly for the presence of water at the lowest possible points inside the primary tank. Remove any water found. Water and sediment in fuel can cause plugging of filters. Also, bacterial growth, in this media, can cause filters to plug and cause corrosion of tanks and lines. For procedures on how to check for the presence of water and removal of water, refer to STI RP111, Storage Tank Maintenance. For copies of the RP and more information, please go to www.stitank.com.
5.5 Tank relocation requirements - Aboveground storage tanks are often relocated. The following instructions are to be followed when this occurs. All steps are to be documented and the documentation is to be kept for the life of the tank.

5.1 The tank operator should perform periodic walk-around inspections to identify and repair areas of damage to the tank or the coating. Check for proper drainage around the tank area.
5.2 It is imperative that the tank exterior be inspected periodically to ensure that the integrity of the coating is maintained. The frequency of periodic repainting will be based upon environmental factors in the geographic area where the tank is located. Special consideration should be given to the selection of the paint, surface preparation and coating application. The coating selected should be suitable for use with the current coating, or the existing coating should be removed. The coating selected should be of industrial quality.
5.3 Proper site preparation and maintenance are vital to ensure drainage of surface water. Should ground conditions change or settlement occur, take the appropriate steps to maintain proper drainage and prevent standing water near or under the tank area.
5.4 For diked tanks, remove any product spills immediately. Be sure to dispose of hazardous material properly.
5.3.2 For diked tanks fitted with a drain, drain off water only. Drain openings are required to be maintained liquid tight.
5.4 The primary tank should be inspected monthly for the presence of water at the lowest possible points inside the primary tank. Remove any water found. Water and sediment in fuel can cause plugging of filters. Also, bacterial growth, in this media, can cause filters to plug and cause corrosion of tanks and lines. For procedures on how to check for the presence of water and removal of water, refer to STI RP111, Storage Tank Maintenance. For copies of the RP and more information, please go to www.stitank.com.
5.5 Tank relocation requirements - Aboveground storage tanks are often relocated. The following instructions are to be followed when this occurs. All steps are to be documented and the documentation is to be kept for the life of the tank.

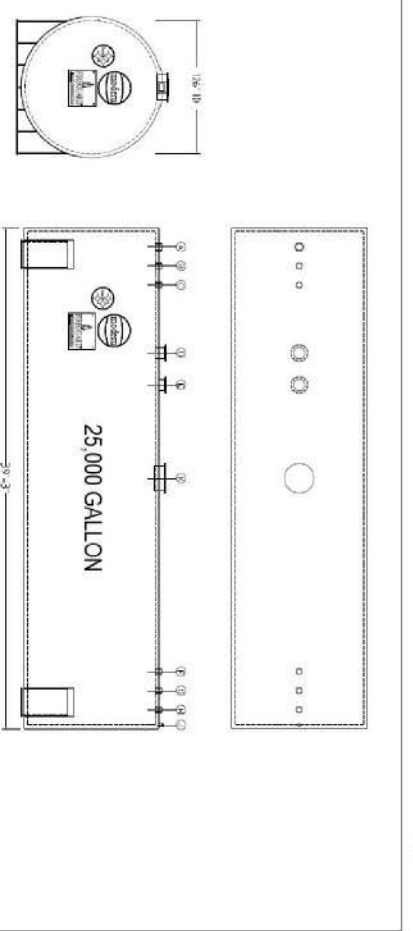
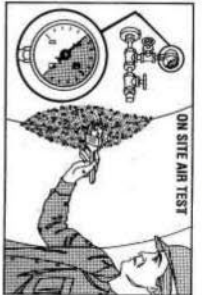
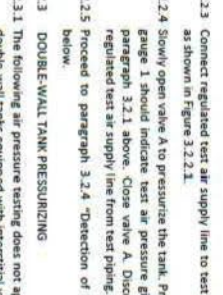

ITEM	DESCRIPTION	QUANTITY	REMARKS
1	25,000 GALLON TANK	1	
2	TEST AIR SUPPLY LINE	1	
3	VALVE A	1	
4	VALVE B	1	
5	VALVE C	1	
6	PRESSURE GAUGE 1	1	
7	TEST SOLUTION	1	
8	SAFETY VEST	1	
9	SAFETY GOGGLES	1	
10	SAFETY GLOVES	1	
11	SAFETY SHOES	1	
12	SAFETY HAT	1	
13	SAFETY BELT	1	
14	SAFETY LIFELINE	1	
15	SAFETY ANCHOR	1	
16	SAFETY HOOK	1	
17	SAFETY SNAPS	1	
18	SAFETY RINGS	1	
19	SAFETY CATCHERS	1	
20	SAFETY NETS	1	
21	SAFETY LINES	1	
22	SAFETY CONNECTORS	1	
23	SAFETY END FITTINGS	1	
24	SAFETY COUPLERS	1	
25	SAFETY WELDS	1	
26	SAFETY TIG WELDS	1	
27	SAFETY MIG WELDS	1	
28	SAFETY BUTT WELDS	1	
29	SAFETY BEVELS	1	
30	SAFETY GRINDING	1	
31	SAFETY POLISHING	1	
32	SAFETY CLEANING	1	
33	SAFETY PAINTING	1	
34	SAFETY COATING	1	
35	SAFETY SEALING	1	
36	SAFETY INSULATION	1	
37	SAFETY PROTECTIVE FILMS	1	
38	SAFETY TAPES	1	
39	SAFETY MARKERS	1	
40	SAFETY MEASURING TOOLS	1	
41	SAFETY RECORDING DEVICES	1	
42	SAFETY COMMUNICATION DEVICES	1	
43	SAFETY SIGNAGE	1	
44	SAFETY TRAINING MATERIALS	1	
45	SAFETY DOCUMENTATION	1	
46	SAFETY PERSONNEL	1	
47	SAFETY EQUIPMENT	1	
48	SAFETY SUPPLIES	1	
49	SAFETY SERVICES	1	
50	SAFETY INSURANCE	1	

GENERAL NOTES

- ALL DIMENSIONS ARE IN INCHES UNLESS OTHERWISE SPECIFIED.
- ALL MATERIALS SHALL BE AS SPECIFIED IN THE MATERIAL SPECIFICATIONS.
- ALL WELDS SHALL BE AS SPECIFIED IN THE WELDING SPECIFICATIONS.
- ALL PAINTS AND COATINGS SHALL BE AS SPECIFIED IN THE PAINT AND COATING SPECIFICATIONS.
- ALL SAFETY EQUIPMENT SHALL BE AS SPECIFIED IN THE SAFETY EQUIPMENT SPECIFICATIONS.
- ALL SAFETY DOCUMENTATION SHALL BE AS SPECIFIED IN THE SAFETY DOCUMENTATION SPECIFICATIONS.
- ALL SAFETY PERSONNEL SHALL BE AS SPECIFIED IN THE SAFETY PERSONNEL SPECIFICATIONS.
- ALL SAFETY SUPPLIES SHALL BE AS SPECIFIED IN THE SAFETY SUPPLIES SPECIFICATIONS.
- ALL SAFETY SERVICES SHALL BE AS SPECIFIED IN THE SAFETY SERVICES SPECIFICATIONS.
- ALL SAFETY INSURANCE SHALL BE AS SPECIFIED IN THE SAFETY INSURANCE SPECIFICATIONS.

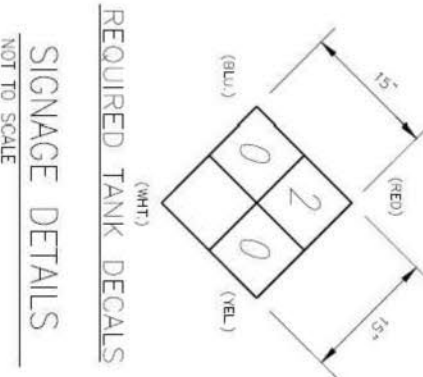

NOT TO SCALE
UNLESS OTHERWISE SPECIFIED

SHEET TITLE:
PIPING, SUMPS & INSTRUMENTATION

REV	DATE	DESCRIPTION

PROJECT INFORMATION

DATE: 2/10/2025 DRAWN BY: JH
SITE #: 20771 PROJECT #: 20066
SHEET: M-200

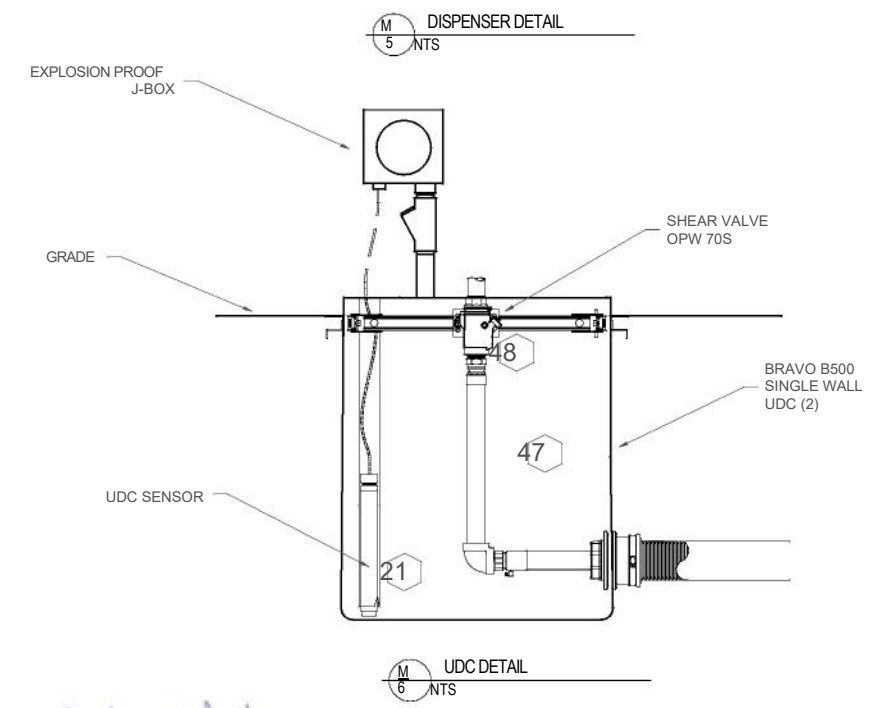
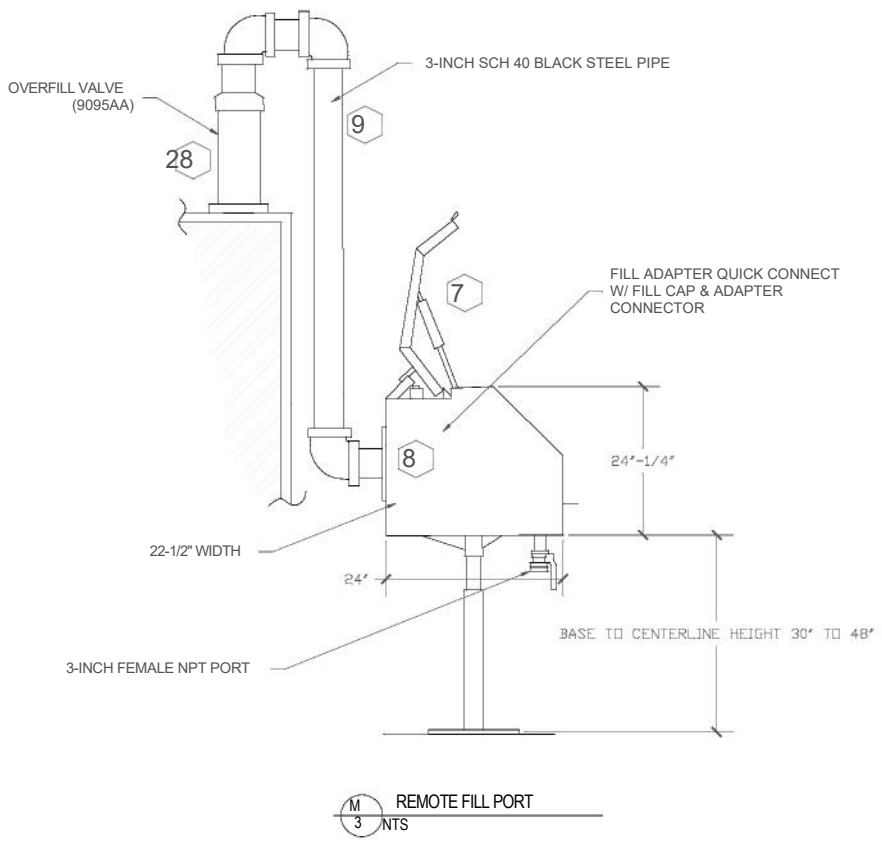
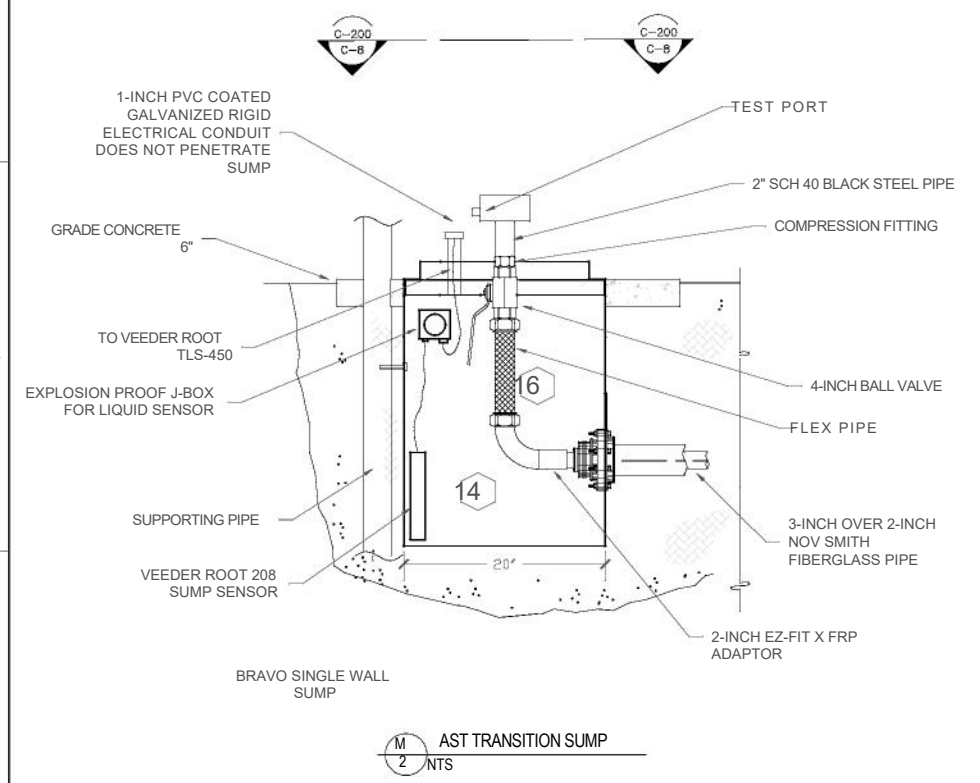
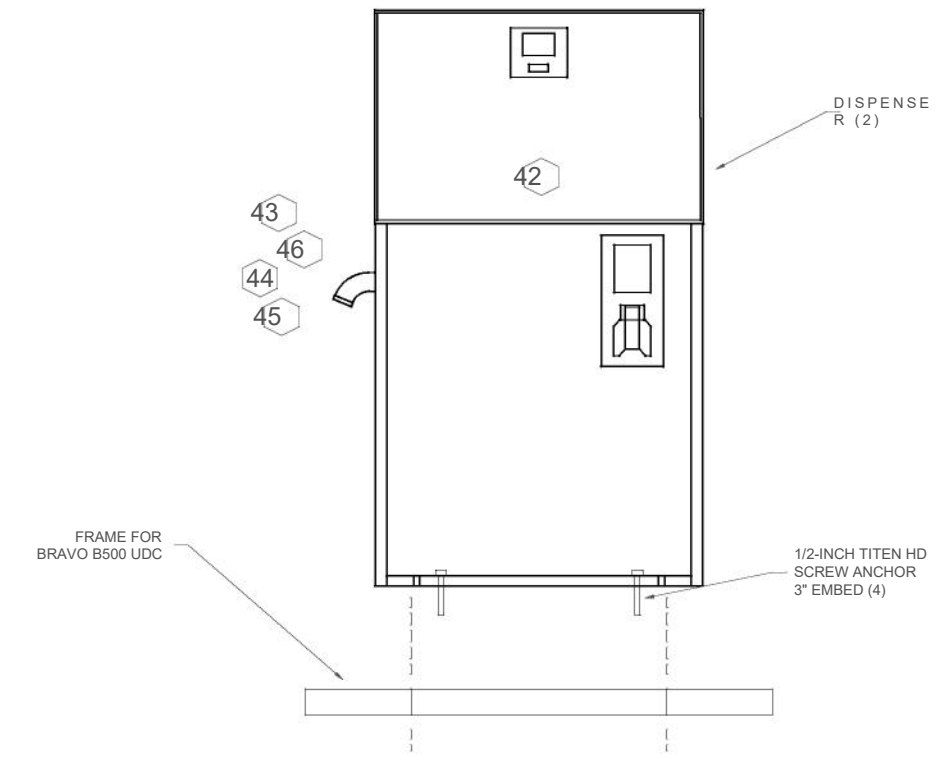
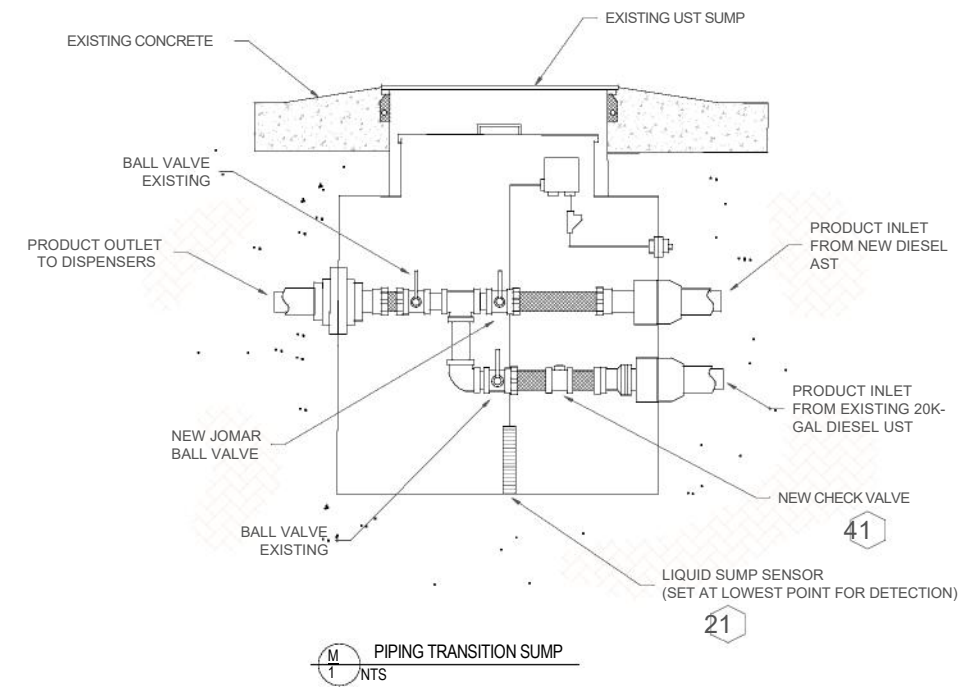

1 DENOTES MATERIAL LIST ITEM

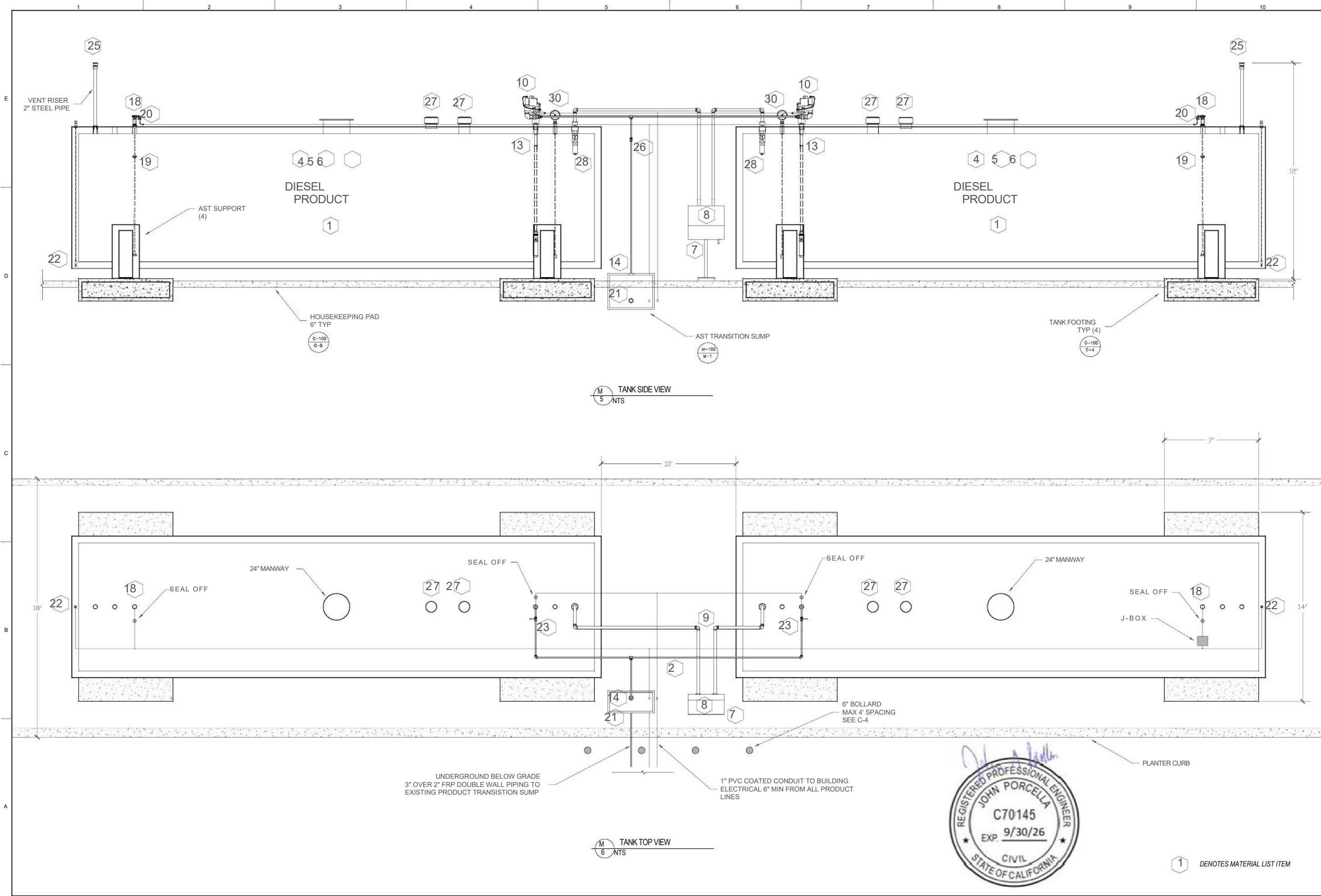

M-5 TANK SIDE VIEW
NTS

M-6 TANK TOP VIEW
NTS

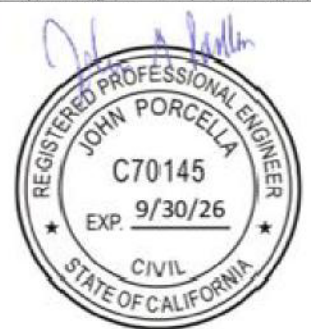

NOT TO SCALE
REVISIONS: THIS DRAWING MAY BE MADE WITH
WITHOUT THE SIGNATURE OF REGISTERED AND LICENSED ENGINEER

SHEET TITLE:
AST DETAILS

THE USE OF THESE DRAWINGS AND SPECIFICATIONS SHALL BE RESTRICTED TO THE ORIGINAL USE FOR WHICH THEY WERE PREPARED. REUSE, REPRODUCTION, MODIFICATION OR ALTERATION OF THESE DRAWINGS WITHOUT THE WRITTEN CONSENT OF THE ENGINEER OR REGISTERED AND LICENSED ENGINEER IS PROHIBITED.

REV	DATE	DESCRIPTION	DES	CHK

PROJECT INFORMATION:
DATE: 2/10/2025
DRAWN BY: JH
SITE #: 20771
PROJECT #: 20066
SHEET: M-300

1 DENOTES MATERIAL LIST ITEM

#	QTY	PART DESCRIPTION	MANUFACTURER	MODEL NUMBER
AST				
1	2	25,000-GALLON DOUBLE WALL FIREGUARD UL-2085 AST	MODERN WELDING	N/A
2		2" SCH 40 BLACK STEEL	N/A	N/A
3		ASTM A 53 & FITTINGS	N/A	N/A
4	4	"NO SMOKING" SIGNAGE	N/A	N/A
5	4	FLUID CONTENTS SIGNAGE	N/A	N/A
6	4	NFPA LABELS	N/A	N/A
REMOTE FILL				
7	1	3" 15-GALLON REMOTE FILL BOX DUAL PORT	MORRISON BROS.	515-ST0300AC
8	2	DRY DISCONNECT W/ CAP	MORRISON BROS.	927-0300AAEVR
9	40'	3" SCH 40 BLACK STEEL PIPE	N/A	N/A
TURBINES				
10	2	2 HP FIXED SPEED SUBMERSIBLE TURBINE PUMP (ADJUSTABLE LENGTH: 108" TO 168.5")	RED JACKET	410142-002-002
11	2	ISOLATE CONTROL BOX	RED JACKET	880-047-1
12	2	120 VOLT IQ CONTROL	RED JACKET	8801-051-1
13	2	FX1DV DIESEL LEAK DETECTOR	RED JACKET	116-058-51
TRANSITION SUMP				
14	1	TRANSITION SUMP W/ OFF SET ELECTRICAL	BRAVO	B500JPF15-B
15	1	BRAVO B500 ELECTRICAL OFF SET ELECTRICAL	BRAVO	EO-EBS
16	2	2-INCH x 15-INCH FIRE SHIELD SS FLEX CONNECTOR WITH 2-INCH FEMALE X 2-INCH HEX MALE	HOSE MASTER	FSQQ150200-K
MONITORING SYSTEM				
17	1	TLS 450 ATG CONSOLE	VEEDER ROOT	8600091-302-SPARE
18	2	10 FOOT MAGPLUS MAGNETOSTRICTIVE TANK PROBE-0.1GPH	VEEDER ROOT	846390-109
19	2	4-INCH MAG PLUS FLOAT KIT FOR DIESEL WITH 5 FOOT CABLE	VEEDER ROOT	846400-001
20	2	TANK PROBE CAP AND RING KIT	VEEDER ROOT	312020-952
21	1	PIPING SUMP SENSOR W/ 12 FOOT CABLE	VEEDER ROOT	794380-208
22	2	ANNULAR SPACE SENSOR FOR STEEL TANKS	VEEDER ROOT	794390-420
TOP OF TANK				
23	3	2-INCH FULL PORT BRASS BALL VALVE	MORRISON BROS.	500-308
24	2	2-INCH EMERGENCY VALVE	MORRISON BROS.	365SS
25	2	VENT CAP	OPW GLOBAL	23-0033
26	2	DUCTILE IRON EXTERNAL RELIEF VALVE	MORRISON BROS.	346DI-0500AV
27	4	8-INCH EMERGENCY VENT	MORRISON BROS.	2440M-0600AV
28	2	2-INCH OVERFILL VALVE	MORRISON BROS.	9095AA
29	2	4-INCH MONITOR CAP AND ADAPTER	MORRISON BROS.	305XPAD100ACE VR
30	2	CLOCK GAUGE	MORRISON BROS.	818-0100AGEVR
PIPING NOV-REV THREAD				
30	25'	2-INCH FIBERGLASS PIPE	SMITH	011030-069-2
31	25'	3-INCH FIBERGLASS PIPE	SMITH	011040-069-2
32	5	2-INCH SLEEVE COUPLING	SMITH	012020-101-8
33	1	2-INCH 45 DEGREE ELBOW	SMITH	012020-310-4
34	2	2-INCH 90 DEGREE ELBOW	SMITH	012020-360-4
35	5	3-INCH SLEEVE COUPLING CLAMSHELL	SMITH	012030-101-3
36	5	3-INCH SLEEVE COUPLING	SMITH	012030-101-8
37	1	3-INCH 45 DEGREE ELBOW	SMITH	012030-310-4
38	2	3-INCH 90 DEGREE ELBOW	SMITH	012030-360-4
39	10	PSX 20 ADHESIVE	SMITH	60210101
40	4	PRP 3-INCH SUMP PENETRATION/TERMINATION FITTING	SMITH	012030-626-0
41	1	CHECK VALVE MODEL 246 SERIES	MORRISON BROS.	
DISPENSERS				
42	2	BENNETT 3K BIG FUELER REMOTE SINGLE PRODUCT / SINGLE HOSE W/PULSER	BENNETT	3711BMR-37
43	2	1" HOSE RETRACTOR W/FOOT BASE	UNIVERSAL	871-HB125
44	2	HIGH FLOW 1" TRUCK NOZZLE (GREEN NO HOLD OPEN CLIP PER UL)	OPW GLOBAL	7H-0100
45	4	10' X 1" MALE X MALE SWIVEL HOSE	VST	V10CPG-120-MRMS
46	2	1" DRY RECONNECTABLE BREAKAWAY	OPW GLOBAL	68EZR-1010
UDC'S				
47	2	BRAVO B500 SW UDC WITH FRAME FOR BENNETT 3K FUELER W/SINGLE PRODUCT BRACKET & OFFSET ELECTRICAL	BRAVO	B500 SINGLE WALL
48	2	SHEAR VALVE	OPW GLOBAL	10BFP-5726
49	2	2" X 12" FLEX HOSE EZ X EZ ENDS (EZ FIT W/1.5" NPT & EZ FIT 90 W/FIXED FRP)	HOSEMASTER / FLEXING	(CUSTOM)
50	2	FRP 3" AB2481 SUMP PENETRATION/TERMINATION FITTING	SMITH	012030-626-0
51	2	FRP 4" X 3" CONCENTRIC REDUCER USE W/3" AB2481 FITTING	SMITH	012040-238-3
ELECTRICAL				
52		3/4-INCH SEAL OFF	N/A	N/A
53		1-INCH SEAL OFF	N/A	N/A
54		3/4" JUNCTION BOX	N/A	N/A
55		1" PVC COATED GALVANIZED RIGID ELECTRICAL CONDUIT	N/A	N/A
56		WIRES	N/A	N/A
BOLLARDS				
57		BOLLARDS	N/A	N/A

GENERAL NOTES

- POINT OF SALE DEVICES SHALL COMPLY PER CBC
 - 11B-220.2
 - 11B-707-2
 - 11B-707.3
 - 11B-707.7.2
 - 11B-707.9
- FUEL DISPENSERS SHALL COMPLY PER CBC 11B-228 INCLUDING 11B-309 FOR OPERABLE PARTS.



NOT TO SCALE
 WEIGHTS AND DIMENSIONS ARE APPROXIMATE
 UNLESS OTHERWISE SPECIFIED

SHEET TITLE:
BILL OF MATERIALS

REV.	DATE	DESCRIPTION



PROJECT INFORMATION:

DATE: 2/10/2025 DRAWN BY: JH
 SITE #: 20771 PROJECT #: 29566
 SHEET: M-400



CGRS, Inc.
1301 Academy Court
Fort Collins, CO

PROJECT: County Connection Bus
Location: 2477 Arnold Industrial Way, Concord, CA 94520
Reviewed by: J. Porcella

PAGE
1 OF _3_
SP-001 Inspector
AST- 40310

Reference /Code

Prepared by J. Hendricks

Date 3/20/2025

Client
County Connection

Tank Data

Length	471 in	Volume (inner)	25000 gal	Note: length is outer tank.
Diameter	126 in	S.G Liquid	0.85	Note: height is outer tank.
Diameter	132 in	Liquid Wt.	177,225 lbs	
Product	Diesel	Tank Wt.	57,100	Similar Manuf. + Equip.
Est. Wall Thick	0.1875	Work on top	20 lbs./SF	
Gallons 2nd Cont	25422	Dead Weight	234,345 lbs.	

ASCE 7-22
13.2.2
Chap 13
Non-
STRU IBC-
22

Load Analysis

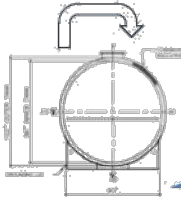

1. $1.4D$
2. $1.2D + 1.6L + 0.5(L_r \text{ or } S \text{ or } R)$
3. $1.2D + 1.6(L_r \text{ or } S \text{ or } R) + (L \text{ or } 0.5W)$
4. $1.2D + 1.0W + L + 0.5(L_r \text{ or } S \text{ or } R)$
5. $1.2D + 1.0E + L + 0.2S$
6. $0.9D + 1.0W$
7. $0.9D + 1.0E$

Moment about support bottom joint

Footing Ht (in) 2 Tank Elevation (ft) 0

Note if elv > 2', see ASCE 7

Tank Moment Arm Height 67 inches Moment arm width: 66 inches

Wind Loads Concord, CA

Design wind speed, Exposure C, Risk 87 mph*
Kz 1
Kzt 1
Kd 0.95
Notes: 300-yr
Kz Urban (B) 0-15ft
Kd Tank Square (0.9) Round (0.95)
Wind load largest tank area.

Pres. on Tank = 18.4 lbs./S.F.
Wind Load = 7,948 lbs.
Empty Wind Tip Check (assume no bolts)
Wt. Down 3,391,740 Wind tip 532,487 = 6.37 **OK**

ASCE 7-22
Table 1.5-1
E.3.1

Seismic Loads Concord, CA

Sds = 1.530 R= 3 Sms 2.280
Sd1 = 1.060 Site Class D T_L 8 sec
Ss 2.210 Risk IV Q 0.67
S1 0.690 Occupancy IV K 1.5 Safety factor
Exposure B
I= 1.5

13.3.1

Simple case Horz. Force $F_p = \frac{0.4a_p S_{DS} W_p}{\left(\frac{R_p}{I_p}\right)} \left(1 + 2\frac{z}{h}\right)$ Fp = 86,051 (lbs)

Assume tank

sloshing will

be minimal

Tank acts as

Max $F_p = 1.6S_{DS} I_p W_p$ Fp = 860,515
Min $F_p = 0.3S_{DS} I_p W_p$ Fp = 161,347

Chose this.

13.3.1.6

Non-structural component Vert. Force $F_v = 0.2 * S_{ds} * W_p$ Fv = 71,710 **Chose this.**

Snow Load 0 lbs./ft Snow Load 0 lbs.

Reference /Code	CGRS, Inc. 1301 Academy Court Fort Collins, CO		PROJECT: County Connection Bus			PAGE
			Location: 2477 Arnold Industrial Way, Concord, CA 94520			_2_ OF _3_
	Prepared by J. Hendricks		Reviewed by J. Porcella	Client		SP-001 Inspector
			Date 3/20/2025	County Connection		AST- 40310
Load Summary per ASCE 7-16 LRFD						
Max Vertical Loads lbs. # Supports 2 (164,042) lbs.						
(328,083) lbs. 161,347 lbs.						
Max Horizontal Loads lbs.						
10,810in*kips Wind 532 in*kips						
161,347 11,600in*kips Wind 3,392 in*kips						
Vertical Tip Tension 1.07 6						
(11,780) 790in*kips Wind 2,859 in*kips						
Notes: Tank is Anchored						
Number of straps 0						
Minimum Strap requirement NA lbs						
Manufacturer's strap capacity NA lbs OK						
ASCE 7-22 15.7.6.1.5	Sliding resistance			Anchor Bolt Properties		
	Friction	Not exceed $V_h < W_t * 0.3$	70,304	Dia.	0.75 in	Titen HD
	$V_h =$	161,347	Will Slide	F_{uta}	110.0 ksi	4, = 0.75 tension, 0.65 shear
	If tank will slide see anchor below.			F_y	97.0 ksi	Rebar N/A
	With Anchoring, tank passes sliding			H_{ef}	6 in	Assume: Cracked concrete
				Edge	18 in	Min Spacing OK
				#	8	
Anchoring ACI 318-14	Anchoring Failure modes: (6) Tension (3) shear					
				Tension		
	1.) Steel Failure in Tension	4,	0.75	OK		
	All bolts			257,120 lbs.		
	Single anchor	32,140 lbs.	1/2 anchors	128,560 lbs.		
	2.) Concrete Breakout Tension	4,	0.70	OK		
	1.5Hef < edge			Cracked Concrete		
	4,Ncbg	13,664 lbs.				
	3.) Side Face Blowout	Hef enough		Blowout Not needed		
	Note:			Bolt edge distance > 2x Hef		
	4.) Splitting	Hef enough		Splitting Not needed		
	Note:			Bolt edge distance > 2x Hef		
	5.) Pullout Failure			OK		
	4,Np	18,035 lbs./anchor				
	Tension 1/3	(3,930) lbs./anchor				
	6.) Bond Failure			Epoxy anchor OK		
	Note:			Epoxy not used		
	1.) Shear steel	4,	0.65	OK	Controls	
	Max Shear			161,347 lbs.		
	Single anchor	27,855 lbs.	All anchors	222,837 lbs.		
	2.) Shear concrete breakout	4,	0.70	OK		
	single	21,746 lbs.	All anchors	173,969		
	3.) Shear pryout concrete	4,	0.70 Kcp =	2.00 OK		
	Single	39,040	All anchors	312,317lbs.		

**CGRS, Inc.**1301 Academy Court
Fort Collins, CO

Prepared by J. Hendricks

PROJECT: County Connection Bus

Location: 2477 Arnold Industrial Way, Concord, CA 94520

Reviewed by J. Porcella

Client

Date 3/20/2025

County Connection

PAGE

_3_OF_3_

SP-001 Inspector

AST- 40310

Reference /Code

NOTES:		No signs of cracked concrete.		OR	Signs of cracked concrete at footing	
Estimated Slab Size		# Supports	2	(2) Pier Beams (8'x15' 24" deep)		
Length	15 ft	Width Support	24	in	pressure top of pad	
Width	8 ft	Area Supports	4,320	8,640	in^2	27.12
				60.00	ft^2	569.21
						MOR (psi)
						OK
Slab On Grade Flexure - No Rebar						
Input Parameters:				Loads		
Slab Thickness	24 in	Tank/Fittings	57,100 lb.			
Concrete Str.	4,000 psi	Liquid	177,225 lb.			
Concrete Unit Wt.	150 pcf	Total	234,325 lb.			
Reinforcement fy	60,000 psi	Factored Dead Load 1.4	328,083 lbs			
Subgrade Mod.	100 pci	Area of Contact	8,640 in^2			
Poisson Ratio (m)	0.15	Safety Factor	1.15 Extra Safety due to unknown soil			
Flexure Stress:						
Effective Radius: a =	52.5 in					
Modulus Elastic: Ec	3,834,254 psi					
Modulus Rupture: Mr	569 psi					
Cracking Moment: Mr	54.6 ft-k per foot					
Radius of Stiffness Lr	82.0 in					
Equivalent Radius: b	35.2 in					
Load Actual 1	457.5 psi					
Fb (allowed)	495.0		OK			
Slab Bearing Stress						
Actual Bearing	38.0 psi					
Allowed	2,391 psi		OK			
Slab Puncture						
Shear Perimeter	372 in					
Fv Actual	29.2 psi					
Fv Allow	154 psi		OK			
Joint Spacing						
No further than	54 Ft		3/4" aggregate Size			



SIGNED: 3/21/2025